



FEED ^{THE} FUTURE

The U.S. Government's Global Hunger & Food Security Initiative



PRACTICAL POULTRY RAISING

(MAY 2015 REVISED EDITION)

PEACE CORPS PUBLICATION NO. M0011



USAID
FROM THE AMERICAN PEOPLE



Knowledge and Learning Unit

The Peace Corps' Knowledge and Learning Unit (KLU), a department of the Office of Overseas Programming and Training Support, makes the strategies and technologies developed by Peace Corps Volunteers, their co-workers, and their counterparts available to development organizations and workers who might find them useful. KLU works with Peace Corps technical and training specialists to identify and develop information to support Volunteers and overseas staff. KLU also produces and distributes training guides, curricula, lesson plans, project reports, manuals, and other material.

Peace Corps-generated materials are also developed in the field. Some materials are reprinted "as is"; others provide a source of field-based information for the production of manuals or for research in particular program areas. Materials submitted to KLU become part of the Peace Corps' larger contribution to development.

This publication was produced by the Peace Corps with funding from the U.S. Agency for International Development's Bureau of Food Security. It is distributed through KLU. For further information about KLU materials (periodicals, books, videos, etc.) and information services, or for additional copies of this manual, please contact KLU and refer to the KLU catalog number that appears on the publication:

Peace Corps

Overseas Programming and Training Support Knowledge and Learning Unit

1111 20th Street
Washington, DC 20526
Tel: 202.692.2640
Fax: 202.692.2641

Abridged Dewey Decimal Classification (DDC) Number: 636.5

Share your experience!

Add your experience to the Peace Corps library of resources. Send your materials to us so we can share them with other development workers. Your technical insights serve as the basis for a generation of KLU materials, reprints, and training materials. They also ensure that KLU is providing the most up-to-date and innovative problem-solving techniques and information available to you and your fellow development workers.

Practical Poultry Raising

The Peace Corps

Publication M0011

April 2015

Table of Contents

Introduction	9
Ch 1: Overview of Poultry Production	11
What Is Poultry?	11
Why Raise Poultry?	12
Disadvantages of Poultry	13
Items Needed to Raise Poultry	13
Resources Needed to Expand Beyond the Farmyard Flock	14
Ch 2: Assessing the Local Context	16
Management Systems	16
International Technical Assistance Agencies	22
Market Network	22
Ch 3: Overview of Chickens	23
Characteristics of Chickens	23
External Anatomy of Chickens	24
Internal Anatomy of Chickens	26
Handling Live Chickens	27
Catching Chickens	29
Ch 4: Country Chickens	30
Why Work with Country Chickens?	30
Gathering Information	31
Possible Management Improvements	32
Upgrading the Flock	34
Farmer Assessments	35
Ch 5: Poultry Husbandry	36
Breed Source	36
Layer Breeds	37
White Eggs	37
Brown Eggs	37
Meat Breeds	38
Dual-Purpose Breeds	38
Starting a New Flock	39
Day-Old Chicks	39
Started Pullets	39

Table of Contents

Hatching Chicks.....	40
Incubation.....	41
Egg Selection.....	42
Incubator Management.....	43
Candling Eggs.....	46
Brooding Chicks.....	47
Brooding the Chicks.....	54
Meat-Breed Management.....	55
Layer Management.....	55
Lighting.....	57
Forced Molting.....	60
Culling.....	60
Other General Management Principles	65
Males and Females.....	66
Mortality.....	66
Hot Weather.....	66
Cannibalism.....	66
Debeaking.....	67
Indigenous Practice and Poultry-Raising.....	67
Rat Control.....	68
Ch 6: Housing and Equipment.....	69
Free-Range Systems.....	69
Contained, Limited-Range Systems.....	69
Contained Systems.....	70
Building a Chicken House.....	73
Making Wire Cages.....	79
Use of Cages.....	81
Feeders.....	86
Grit Hoppers.....	90
Nests.....	92
Roosts.....	93
Ch 7: Keeping Chickens Healthy.....	94
Diseases.....	95
Prevention by Vaccination.....	95
Diagnosis.....	96
Parasites.....	102

Table of Contents

Other Health Problems.....	104
Performing a Postmortem Examination.....	104
Ch 8: Feed and Nutrition.....	107
Commercial Feeds.....	108
Feeding Methods.....	109
Nutrient Requirements of Poultry.....	110
Non-nutrient Feed Substances.....	112
Ingredient Use Limits.....	113
Sources of Feed Nutrients.....	113
Formulating a Ration.....	113
Using a Protein Concentrate.....	118
Mixing Feeds.....	119
Grinding Feed.....	120
Storing Feed.....	120
Nutritional Deficiencies.....	121
Vitamin Deficiencies.....	121
Other Deficiencies.....	122
Points to Consider Before Using Nontraditional Ingredients.....	123
Ch 9: Poultry Marketing and Finances.....	124
Marketing Country Chickens.....	124
Marketing Medium-Sized Broilers.....	125
Weighing Chickens.....	127
Storing Eggs for Market.....	127
Cleaning Eggs.....	127
Egg Grading.....	128
Storing Eggs for Home Consumption.....	128
Size of Flock.....	129
Records.....	130
Increasing Poultry Profits.....	132
Sources of Finance.....	133
Poultry and Egg Cooperatives.....	134
Ch 10: Poultry Extension.....	135
Contact Poultry Farmers.....	135
Timing of Suggestions.....	135
Training.....	136

Table of Contents

Special Poultry Projects.....	136
Appendix A: Housing Designs.....	139
Night Shelter.....	142
Raised-Floor House.....	143
Deep-Litter House.....	144
Pole-Type House.....	145
Kerosene-Heated Incubator.....	146
Appendix B: Other Poultry.....	148
Ducks.....	148
Geese.....	149
Guinea Fowl.....	150
Turkeys.....	151
Pigeons.....	152
Appendix C: Farmer-Specific Assessment Criteria.....	153
Appendix D: Feed Formulation Chart.....	157
Appendix E: Feed Requirements.....	167
Energy Requirements.....	167
Vitamin Requirements.....	167
Protein and Amino Acid Requirements.....	168
Mineral Requirements.....	169
Maximum Limits of Feed Ingredient Use.....	169
Appendix F: Bibliography and Resources.....	171
Bibliography.....	171
Resources.....	172
Appendix G: Glossary.....	173

As part of the United States' "whole of government" effort to address food security in the developing world, the Peace Corps has edited and revised several technical manuals designed for use by Volunteers. Most of these materials were created in the late 1970s and early 1980s and were written by a number of different subject-matter experts employed or contracted by the Peace Corps. The manuals have been revised with funding provided to the Peace Corps by the U.S. Agency for International Development (USAID) Bureau of Food Security under a food security agreement known as "Feed the Future."

Given Volunteer and staff needs to access information on a wide range of topics related to food security, these manuals and their accompanying references were selected, reviewed, and updated by subject-matter experts. Although some years have passed since they were first written, the content covered in these manuals, particularly the basic concepts, has changed very little, if at all. Importantly, references in each of the manuals have been reviewed and updated, where necessary, and websites have been added to allow the reader to locate additional and more recent supporting content.

This manual is designed to provide development workers with the information and tools to begin or improve poultry production. For those who are inexperienced in poultry production, this manual can identify and provide the basic information needed to raise and market poultry successfully. More experienced poultry workers may find the sections on Assessing the Local Context (Chapter 2), Feed and Nutrition (Chapter 8), Poultry Extension (Chapter 10), and Bibliography and Resources (Appendix F) useful for adapting their knowledge and skills to the conditions of a new environment. Regardless of your level of poultry experience, you can help expand poultry production by helping farmers observe, question, and find the gaps between actual and potential production, by suggesting improvements and helping farmers evaluate the results.

Numerous sources were consulted in order to make this manual useful for raising poultry under varying conditions.

This manual explores many different aspects of raising and marketing poultry based upon these sources and the authors' and reviewers' experiences. Because ideas about poultry production vary greatly in different countries, **it is highly recommended, wherever possible, that a review of this manual by a responsible officer within the appropriate government ministry be conducted before the suggestions made in the manual are implemented.** Special climatic considerations, feed ingredient problems, disease considerations, and other conditions can make sections of this manual inappropriate in certain areas of the world. If there are questions about the appropriateness of recommendations made in the manual, the experience of local authorities should have priority until research can be done to show the value of the new methods. It should be also be noted that sources consulted for this manual do not always agree. On one issue, four highly experienced sources each gave different

Introduction

recommendations for the same conditions. To make this manual most useful, methods and tools described are based either on a majority opinion or on the experience of the authors.

Because this manual gives general instructions on poultry production, some recommendations and suggestions will not be relevant to every Volunteer's situation. Poultry workers will need to adapt methods and tools to their specific needs. We would therefore appreciate your comments, corrections, and suggestions for future editions of this manual. What information was the most useful? What was not covered that would be useful in revised editions? How did you use this manual? What was irrelevant or not useful? Please make comments and let us know how this manual helped you in poultry production.

What Is Poultry?

The word *poultry* applies to all domestic fowl raised for their eggs, their meat, or both. Poultry includes chickens, turkeys, ducks, geese, guinea fowl, pheasants, quail, and pigeons. Chickens are, by far, the most popular poultry raised today, and this manual concentrates on them. Brief attention to other fowl is given in Appendix B.

The first chickens (probably the species *Gallus gallus*) were lured or captured from the rainforests of southwest Asia more than 3,000 years ago. Since that time, chickens have been kept for meat and eggs by nearly every human group throughout the world. Over the years, the original chicken has been bred by selection and circumstance into many varieties.

Until recently, almost all chickens were raised in small flocks and left to look after themselves. In many areas of the world, chickens still are raised a few at a time for occasional eggs or feasts. Some people grow chickens exclusively for cockfighting or religious rituals. Some types of chickens with beautiful plumage are raised just for show.

In the past half-century, the growing need for protein to feed the world's rapidly expanding population has caused farmers and scientists to pay more attention to chickens as food sources and increase the efficiency with which they are raised. Genetic research has developed many different breeds and varieties adapted to different climates, farming methods, and purposes.

Types of Chickens

Even though there are many breeds and varieties of chickens used in farming, they all can be divided into three types:

- **Layers:** Bred primarily for egg production, these birds usually weigh 1 to 2 kilograms (2.2 to 4.4 pounds). They are lighter than chickens bred to produce meat. Because they are smaller, they need less feed to maintain their body weight while laying as many or more eggs than the bigger birds. The layers also are eaten, usually after they have been producing eggs for 1 to 1½ years. Farmers often do not keep the males of these breeds because it takes too much feed to bring them to a marketable weight. Birds that lay brown eggs are usually a little larger than those that lay white eggs.
- **Meat Chickens:** These birds grow rapidly and reach marketable size after 2 to 3 months. They are sold well before they reach egg-laying age. Whether a meat chicken is called a fryer or a roaster depends on its size and age. Meat chickens are usually called broilers. Capons (castrated males) grow large, fat, and tender as they get older.
- **Dual-Purpose Chickens:** These birds are raised for eggs and meat. Females of the new, improved breeds are kept to lay eggs while the males are separated and sold for meat

Ch 1: Overview of Poultry Production

as soon as they reach about 15 weeks. Dual-purpose hens are sold for meat at the end of the laying time. The country chickens roaming free in most villages of the world are a kind of dual-purpose bird. Generally, it is more profitable to specialize in either layers or meat birds, since these improved breeds of chickens can reach very high levels of production. Some layers now produce at an average rate of 90 percent for a whole year.

Meat chickens weighing 2 kilograms (4.4 pounds) or more are ready for market in 7 to 10 weeks. However, unlike country fowl that, through the centuries, has developed resistance to many diseases and learned to take care of itself, these new breeds need the active care of the farmer to protect them from disease and predators if they are to survive and produce well.

Why Raise Poultry?

Protein: Anything number of chickens, from a hen and a few chicks running free up to a group of 50 or so that receive some special care, can provide a family with important dietary protein and perhaps some income through the sale of extra eggs and birds to neighbors. Feeding the birds food scraps and crop byproducts is a good way to use vegetable matter that the family does not eat. One hundred birds or more can significantly increase the local supply of high-quality protein, minerals, and vitamins. This is especially important for young children and for pregnant and nursing mothers.

Profit: By keeping costs low, some farmers can make sufficient profit on a small flock to allow for expansion to a larger flock. Additional advantages include the following:

- Increasing local employment, especially for women. A woman who has access to such a business enterprise and, importantly, its benefits, has the ability not only to look after herself, but also to improve her position in the family and the community, and provides a safety net in case of abandonment. It also enables women to be active outside their communities and create social networks with other women that can provide opportunities for further business development and employment.
- Use of food processing byproducts that are normally wasted.
- Use of relatively little land (chickens can be kept in urban and rural settings).
- Increasing the supply of manure for fertilizer and methane gas production.
- Providing possible benefits when combined with other protein-increase programs (for example, chicken manure can be used to fertilize fish ponds).

Disadvantages of Poultry

Of course, there also are possible disadvantages to raising chickens:

- Livestock, in general, are inefficient producers of food, and people in most developing countries cannot afford to use their scarce resources to raise them.
- Livestock often compete directly with humans for cereal grains such as wheat, soya, and maize (corn).

Medium-sized poultry operations in developing countries have other possible disadvantages:

- Poorly run projects can destroy a small-scale farmer's scant savings or put him or her deeply into debt.
- Market cycles can hurt or destroy a poultry project, even if it is well run.
- Feed, water, or labor stoppages can cause the operation to fail.
- These projects need specially bred birds, pharmaceutical products, markets, transport, and technical advice that may not be found in the area.
- Compared to traditional ways of raising chickens, these projects need a large per-bird investment.

After considering the advantages and disadvantages, most developing countries have decided to encourage poultry production. This encouragement has not yet reached many small-scale farmers. Here is where you may be able to help.

Items Needed to Raise Poultry

Just as humans have certain minimum requirements for life, basic chicken needs must be provided by the farmer if the birds (especially the new breeds) are to be productive: shelter; protection from disease, pests, and predators; temperature and humidity controls; sanitation; control of light; and elimination of stresses.

Examples of stresses are noise and other disturbances, dust, drafts, foul or stale air, crowding, changes in feed, introducing new chickens into established flocks, changes in weather, and keeping males with females. Stress factors are additive, which means the more that a chicken has to bear, the worse the effect may be. An otherwise healthy bird may contract only a mild case of a disease when exposed to it; a bird that has worms, is crowded, or is not eating well may die when exposed to the same disease.

The most important element in poultry raising is a good relationship between the caretaker and the flock. A caretaker must like and understand chickens and be dedicated to seeing that they do well. In short, chickens need tender loving care.

Ch 1: Overview of Poultry Production

Resources Needed to Expand Beyond the Farmyard Flock

Interested farmers: Unless farmers are convinced that poultry raising is a good idea and are ready to provide the constant care and attention, finances, and other support that larger flocks need, there is no point in continuing. You should never attempt to persuade farmers to do something that they don't think is in their best interest.

Cultural acceptability: The chicken has been linked with human society for so long that many cultures have developed special ways of dealing with them. Vegetarians, of course, don't eat chicken meat and many don't eat eggs, especially fertilized ones. Other societies relish eggs in which the fetus already is formed. Some people regard fowl as sacred and will not eat them, while others won't touch them because of the worms and manure that chickens sometimes eat. Some cultures forbid eggs to be fed to pregnant women. There are many other such taboos and traditions throughout the world. In most places, people welcome chickens and eggs to their menus and willingly form a good market, but you must learn from local people about their customs and attitudes if you are to work effectively.

Financial means: Farmers must have available cash of their own, be able to pool their resources through cooperative efforts, or be able to borrow from private sources or government agencies. For small-scale farmers, investing in the new breeds means that a large portion of their resources is not available for other uses. They must realize that they risk losing part or all of their investment. Even if they do make a profit, it may not be for some time—in layer operations this may take at least 1½ years, sometimes longer.

Local supplies and technical support: You must have an assured supply of clean water and fresh, well-balanced feed for the birds' entire lifespan. This is easier to arrange for meat birds that are kept for only a few months than it is for layers, which will need vaccines, medicines, food supplements, and advice on how to use them.

Markets and infrastructure: Even if the people in your area enjoy eating chickens and eggs, they may be too few or too poor to justify an expanded chicken operation. Transport problems may mean that you cannot deliver your products, especially eggs, to market quickly enough so that they are fresh, attractive, and earn a profit. Farmers near towns or good roads usually have good markets, even though competition may reduce their per-bird profits. Those in remote areas often cannot sell as many eggs and birds, but may make up for that by receiving higher prices.

Breed source: A farmer who wants to start a medium-sized poultry operation will need a source of an improved breed. Ways to work with and upgrade flocks of country chickens are described in Chapter 4, but if farmers are to spend their limited resources on buildings, feed, or other support, they should use birds with the greatest genetic potential.

Ch 1: Overview of Poultry Production

Market plans: Farmers will have to determine when to start their flocks so they are ready for laying or sale in the most profitable season, which types of eggs and meat buyers enjoy most, what quantities can be realistically sold if neighboring farmers also are expanding, and what to do about other seasonal problems such as scarcity of labor during harvests and lack of water during dry seasons. These topics are discussed in Chapter 9.

Ch 2: Assessing the Local Context

If you are living in your work area, you probably already know quite a bit about the local poultry situation. You have most likely bought eggs, and perhaps chickens, at the market and know something about the quality and quantity available there. Do people present you with a chicken as a token of their esteem? Does a neighbor's rooster awaken you? Alternatively, have you found yourself downwind from a poorly run chicken coop? We tend to notice first the things that affect us personally.

If you want to see whether you can be effective in poultry production, you must know much more about how the supply or lack of chickens affects the lives of the people around you. Do people eat eggs and chickens often, or save them for festive occasions? Do local restaurants serve them daily? If so, where do they and the market sellers get their supplies? Is the neighbor's rooster or the upwind chicken coop unique, or are there many around? Do you think prices are high or low compared with other local foods? How do local prices compare with those in other areas of your country?

If you are in one of those rare places without chickens, what are the reasons? It may be a temporary condition caused by a severe outbreak of disease, a drastic increase in the predator population, or a long drought. In such cases, you may be able to help reintroduce chickens to the area. In other cases, where people won't eat eggs and chickens and don't want to have them around, you may want to find another activity entirely.

Management Systems

From the small backyard flock to the 100,000-bird automated house, poultry management systems can be classified in any number of ways. We have chosen the following six categories to give you a rough guide to what you may see in your area. You should observe local farmers closely to determine which methods they use and why, learn what they think their problems are, and find out what kind of improvements they would like. Unless you already know quite a bit about chickens and people, you should limit yourself to questions: your purpose at this stage is to learn.

The descriptions and illustrations in this section are included only to show a progression of technology and the basic types of poultry operations. A view in your village may differ somewhat, but the principles will be similar. Following chapters explain advantages and disadvantages of each of the six systems shown here.

*Country Chicken Free Range*¹

In this system, the farmer makes no attempt to control the flock's food or water intake, although they may be thrown an occasional food scrap or handful of grain. The flock finds

¹ In this context, "free range" means free to scavenge for food.

Ch 2: Assessing the Local Context

its own shelter and uses its instincts to avoid predators. The farmer provides no sanitation, and the only vaccinations that may be given are provided by government agents during widespread epidemics. The hen tries to hide her few, small eggs, and often succeeds. She hatches her eggs on her own. The farmer gets very few eggs, little meat, and has very little of either to sell. Losses, especially of chicks, to disease, predators, and theft are high.

Figure 2-1: Country Chicken Free-Range System

Photo c/o creativecommons.org



Partly Controlled Free Range

In this system, the farmer provides overnight shelter and some supplemental feed. Breeding is uncontrolled, but the farmer does provide a nesting place where the brood hen incubates her eggs. The farmer may place other hens' eggs under her as well. (A brood hen is a hen that wants to set and hatch eggs and take care of chicks.) The farmer may make use of the local agricultural extension system for some advice and vaccinations.

Figure 2-2: Partly Controlled Free Range System

Photo c/o creativecommons.org



Ch 2: Assessing the Local Context

Contained with Limited Range

There are many variations of this system. The essential feature is that the flock is kept in a shelter overnight and during bad weather. At other times, the chickens are free to eat any grass and other food they can find within a fenced yard. Sometimes the shelters are small and portable, with wire mesh floors, and are moved frequently to fresh ground and grass within the yard. Other times the shelters are larger and stationary. The chickens may be confined to one yard, or may be rotated every few months to fresh adjacent enclosures.

In limited-range systems, the farmer provides most, if not all, feed and water, sometimes outside and inside the house. The chickens may be from local flocks or from improved breeds. The farmer may have the benefit of technical advice beyond that available from neighbors. If the house is stationary, it may use either a deep-litter or a raised-floor system (see below).

Figure 2-3: Contained, Limited-Range System

Photo c/o creativecommons.org



Figure 2-4: Raised-Floor System

Photo c/o creativecommons.org



Ch 2: Assessing the Local Context

Contained, Deep Litter

In any contained system, the chickens remain inside at all times. The breed source is usually a commercial breeder. The farmer provides all feed and water, nesting boxes, and perhaps perches (roosts) inside the house. The farmer usually has the benefit of technical advice. Losses to predators, disease, and theft are greatly reduced compared with free-range and limited-range systems. The contained system requires a substantial per-bird investment.

The floor of a deep-litter house is covered with up to 15 centimeters (more than 5 inches) of bedding material (e.g., wood shavings; rice, wheat, or other grain hulls; shredded sugarcane or shredded straw) that absorbs moisture from droppings.

Contained, Raised Floor

The characteristics of this system are the same as those of the deep-litter system, except that the chickens live on a raised, semi-open floor, and droppings fall to the ground or to a light layer of litter below. The floor is usually made of spaced wooden slats, but wire mesh or expanded metal is sometimes used. (Expanded metal is sheet metal that has been partially cut and stretched and looks like heavy-gauge wire mesh with diamond-shaped holes.)

Cage or Battery

This system is used only for layers. The hens live in cages, where food and water are provided. The cages may be placed in any sheltered area. The farmer most likely uses extension advice. The per-bird investment may be the highest of all systems, especially if the cages are made of expensive wire.

Can You Help?

We assume that anyone in an area where no chickens are being raised and where there is little hope of introducing them has already traded this manual for other reading material. If you are in an area where large-scale poultry raising is abundant, egg and meat prices are very low, and there is little chance to contribute unless you are a highly skilled technician, you should be looking for something else to do.

Both of the above situations are rare in the developing world. Usually, there is room for improvement of the existing situation. The more you learn about chicken raising in general and about the specifics in your area, the better prepared you will be to help. The following chapters will give you essential facts and some useful ideas for suggesting local improvements. The bibliography lists more reading materials you can order. However, before you dive deeply into technical material, there is an approach to working with people in

Ch 2: Assessing the Local Context

development (in this case, poultry farmers or potential poultry farmers) that we suggest you keep in mind.

Finding the Gap

Almost any poultry operation fails to reach its maximum production potential. You should try to assess the production potential in your area. What you are seeking is not some idealized situation where no error can occur, but what your friends and neighbors can reasonably expect if they work willingly and seek good advice. There is no exact formula for determining production potential, although this manual does give you some production averages that are fair guides. Local conditions and attitudes will always determine the outcome.

As you gauge the technical potential and compare it to the situation, you will identify some degree of difference. Production potential minus the situational factors equals the gap. You will be working to help fill this gap.

Address yourself to the local gap. Don't worry about the big difference between what you see and the results obtained in industrialized countries. Work with possible local advantages: small investments of time, money, and energy may yield relatively large returns; labor and some supplies may be relatively inexpensive in your area; market prices may be high, and minor decreases in prices may increase demand exponentially as poorer people see they now can afford some eggs and meat.

Filling the Gap

The key to filling the gap is increasing control over production factors. This may mean introducing new methods and resources or cutting the costs of those now in use. The gap between the existing and potential situations often can be overwhelming. If you attempt to change everything at once, you and the farmer are likely to become frustrated. To avoid this frustration, break the gap into smaller increments that the farmer can handle. For example, if chickens are overcrowded in a poorly ventilated structure, have intestinal parasites, and are not properly watered or fed, you can first suggest selling a few chickens to simultaneously reduce overcrowding, increase ventilation, and provide proper food and water.

Although small, these changes are not costly, and they will bring rapid results. Then you can begin to address the other problems one at a time. Close the gap by helping farmers select increments that they can most easily absorb and which have the best chances for early, observable results. This manual will describe most of the basic increments that may be of use and help you choose the ones you might suggest. To aid in determining the gap, use the Farmer-Specific Assessment Criteria (Appendix C) for each farmer in your area.

Ch 2: Assessing the Local Context

Evaluating Your Resources

Appendix F lists a few resources available to you, but most of them will be hard to obtain. It always is best to work with local resources. There are likely many local resources available, if you seek them out.

Government Agencies

Before beginning any poultry activities, you should consult with the government poultry agency, usually a part of the Ministry of Agriculture. The people there can tell you about the support they offer, which probably includes recommendations on:

- Vaccinations and medications: dosages, schedules, equipment, emergency programs, and free services available
- Nutrition/feed mix sources: ingredient sources, costs, seasonal fluctuations, and what works best in your area
- Building designs: use of local materials, environmental considerations, and cost reductions
- Water supply availability: water-borne diseases and treatments, equipment sources and designs
- Stock: sources of chicks and pullets (female chickens less than 1 year old), breeds available, and which are the best producers
- Financial assistance: sources and application procedures
- Laboratory facilities: where they are and what they can do
- Cultural considerations: how to work with them
- Local language extension publications: how to obtain them
- Other topics not mentioned in this list (there may be many)

Private Companies

It is in every company's interest to have farmers do well. They often offer information and advice difficult to obtain elsewhere. However, if you have a choice of more than one firm in a field, it is best to check with several and try to balance the various self-interests. Firms to look for include:

- **Breeding companies:** Unless they also are egg and meat producers who might feel threatened by possible competition, information that you receive from these companies should be good.
- **Pharmaceutical companies:** They are good sources of information on diseases and disease control.

Ch 2: Assessing the Local Context

- **Equipment manufacturers:** This may be a local artisan in a small market stall, a shop in a town, or an import distributor. With their local experience, they can help you cut costs and avoid mistakes.
- **Feed suppliers:** They provide feeding recommendations with their ready-mixed feeds. If you plan to mix your own feed, they may advise you on the least costly ingredients and provide vitamin, mineral, and protein supplements.

Cooperatives, Lending, Education, and Research Institutions

You should know where these institutions are and what they can offer. Cooperatives are discussed in Chapter 9. Lending institutions are not just sources of finances; they also can provide information on how to reduce costs and risks. Universities, technical schools, and research laboratories often are sources of much useful information.

International Technical Assistance Agencies

Groups such as the United Nations Food and Agriculture Organization (FAO), the United States Agency for International Development (USAID), and many others may have offices in your country where you can obtain helpful advice and publications. They may even have resident poultry experts. Your local Peace Corps staff may be able to put you in touch with these valuable resources.

Market Network

Everyone you meet who is engaged in poultry production and marketing can offer advice on prices, seasons, supplies, consumer preferences, and other relevant topics. Sometimes their advice may be conflicting and confusing, but more often you will hear a consensus that leads you in the right direction.

The next three chapters describe various poultry care and marketing practices. Once you have these basics in mind, you can use the suggestions in Chapter 9 to identify people who may want to try raising chickens or improve their existing operations. When they have expressed their needs, you and they can begin planning how to meet those needs.

Before planning any poultry production effort, you need some basic information about chickens. If you are inexperienced with these birds, you will need to become familiar with the parts of a chicken, the general appearance of a healthy bird, and the differences between male and female chickens. You do not need to become an expert in chicken anatomy, but to work in poultry production you do need to know what the primary characteristics of chickens are, their normal life cycle, and how to handle live birds. This chapter describes the external and internal anatomy of chickens; such information will be especially useful later when diagnosing and treating chickens for disease.

Characteristics of Chickens

Chickens come in many sizes and colors. They lay eggs, which can range in color from pure white to dark brown, olive green, or speckled. The number of eggs an adult female lays in a year varies from none to 365, or one a day. The typical country chicken, which has had no breed improvement, usually lays between 25 and 100 eggs per year, depending mainly on such conditions as feed, exposure to disease and predators, and weather. Layers usually start producing eggs between 6 and 8 months of age, depending upon their health and the time of the year. The improved breeds start laying at 5 to 6 months of age, and under good conditions will lay between 180 and 365 eggs yearly, with an average flock of 100 birds producing 240 to 280 eggs per layer. There also are improved breeds, which are intended specifically for meat production. Chickens from such breeds can weigh more than 2 kilograms (4.4 pounds) at just 7 to 8 weeks of age.

Chickens hatch from fertilized eggs after 21 days of incubation. In poultry production, incubation can either be by natural means (a brood hen) or by artificial means (an incubator). Before hatching, the chick absorbs the yolk of the egg into its lower body in the yolk sac. This yolk supplies the chick with enough food and water for up to two days, at which time they must begin drinking and eating on their own. Chicks hatch by breaking through an air cell in the large end of the shell. Using their upper beaks, chicks peck a hole through the shell, and then continue to peck at it until the shell is weakened enough so that it can be entirely broken open. This process is called pipping. At hatching, chicks are wet. Within a few hours, they dry out and are covered with a soft down. The first feathers appear within a week on the wing tips and tail; other feathers grow in later.

Chickens mature at different rates, depending on breed, nutrition, and environmental factors. Most will be mature by 6 months. Males are called cockerels until they reach maturity, when they are called roosters or cocks. Before reaching maturity, female chickens are called pullets; once they begin laying, they are called hens. Some farmers refer to a whole flock of female chickens as pullets until the entire flock reaches full egg production.

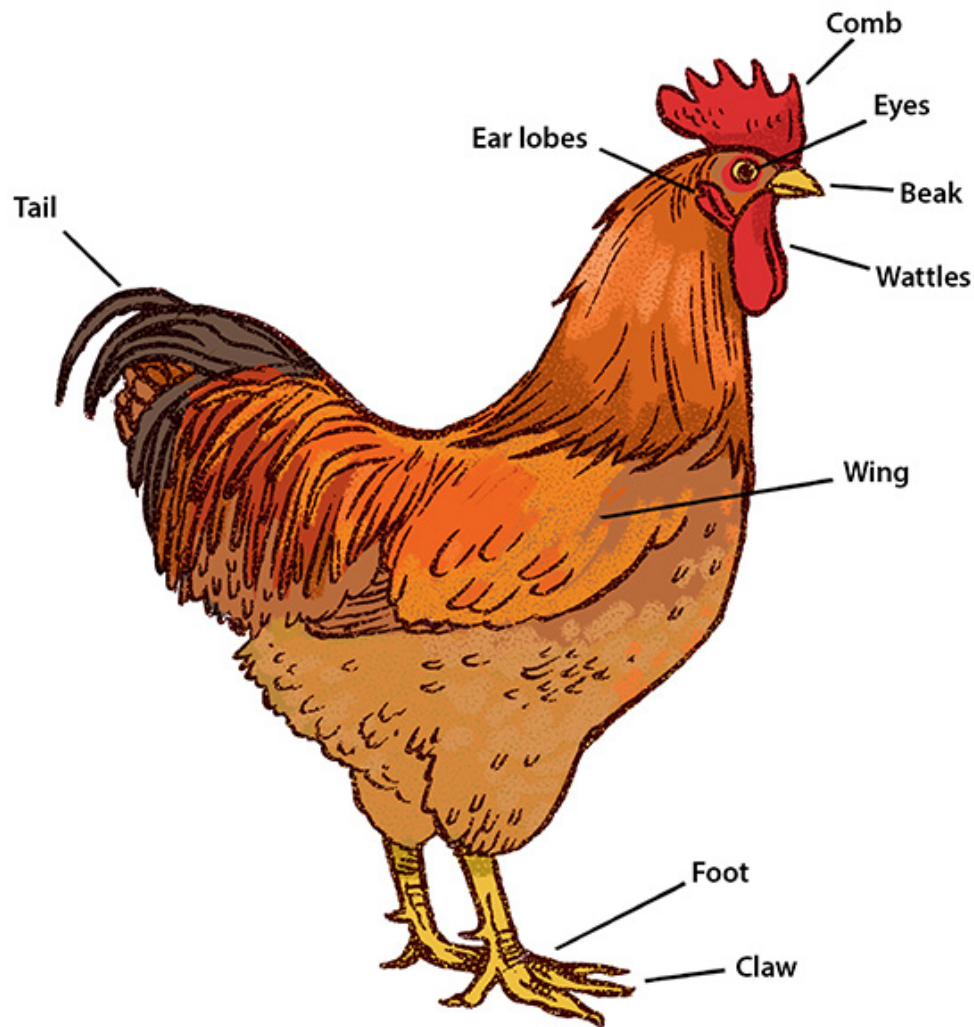
Ch 3: Overview of Chickens

External Anatomy of Chickens

To be able to work with chickens, you first must know the various parts of a chicken and their functions, and how to tell male and female chickens apart. The major external parts of a chicken include:

- **Beak:** The chicken's beak serves three functions. First, it is the chicken's mouth. Second, it is used for fighting and protection. Third, it functions as the teeth of the chicken, enabling the bird to break grass, bananas, and other foods into pieces small enough to swallow.
- **Comb and wattles:** It is believed that the comb and wattles serve to cool the chicken's blood.
- **Ear lobes:** The ear lobes of chickens serve hearing and other ear functions.
- **Eyes:** The eyeball of a chicken is stationary; thus, a chicken must move its head to vary the range of vision.
- **Feathers:** The feathers provide insulation and buffer extremes of heat and cold.
- **Wings:** Chickens cannot fly very well. They can flap their wings sufficiently to raise themselves about 3 meters off the ground.
- **Tail and tail feathers:** The tail is used for balance while walking and, in flying, as a rudder for up-and-down and side-to-side motion.
- **Feet and claws:** In addition to walking, chickens use their feet and claws in fighting (for protection) and in finding food.

Figure 3-1: External Anatomy of a Chicken



There are several differences between male and female chickens that should help in identification:

- **Size:** The males grow taller and, upon reaching maturity, usually outweigh females of the same age by between 0.5 and 1 kilograms (1 to 2 pounds). A male of one breed may weigh less than the female of another breed. This size difference is not apparent until the chicken reaches 4 weeks of age. At 1 day old, there is no difference between male and female chicks.
- **Comb and spurs:** The comb grows much larger on the male. On the female, spurs hardly develop at all when compared with the male.
- **Vocal expressions:** A rooster crows while a hen doesn't. What is not generally known is that roosters crow intermittently all day long, not just in the morning.
- **Feathers:** Adult males' feathers are noticeably different from those of adult females. The most distinguishable are the tail feathers, which are long and stringy on the male.

Ch 3: Overview of Chickens

Male chickens of improved layer breeds are usually destroyed within a day or two after they are taken from the incubator, because it is not economical to raise them for meat. In the case of improved meat breeds, both females and males are raised because both have economic value.

Internal Anatomy of Chickens

Although you are not expected to become an expert, it will be useful to understand the anatomy and functions of different organs of chickens. Chickens do not have stomachs like other animals, but have a different means of food storage and digestion. First, the food enters the beak (mouth) and goes halfway down the esophagus (throat) to a storage area, called a crop, where it is moistened and thus softened. The food then continues down the esophagus and enters what the proventriculus, or “true stomach.” The proventriculus secretes digestive juices (enzymes and acids) and is directly attached to the gizzard, which grinds food up into smaller pieces. Food leaving the gizzard enters the small intestine, where nutrients are picked up by blood vessels and circulated throughout the chicken’s body. Food particles then move into the large intestine, which has two “blind” or dead-end attachments called ceca. (The functions of the ceca are not fully understood.) After digestion in both intestines, the waste materials, including urine and stool, are excreted through one opening called the vent. The excreted material is called feces.

The heart and lungs of a chicken function in the same ways as those of most other animals. Air enters through the nostrils then goes down a tube called the trachea, located beside the esophagus. Both tubes are located on the underside of the neck when the chicken is standing. The entrance to the trachea, called the larynx, is at the back of the mouth. The trachea looks like a thin plastic tube with rings around it. It ends at a Y-shaped junction, from which two bronchial tubes lead to the right and left lungs. The trachea and bronchial tubes look like semi-transparent plastic tubes. The lungs are segmented and located between the rib bones, leading from either side of the backbones. Further back, toward the tail, is the reproductive system. Then, closest to the tail, are pockets in a larger bone, which contain the kidneys. Normal kidneys appear brownish-red.

If you opened the chicken lying on its back, the first thing you would see is the liver, which has two parts, just in front of the soft skin above the vent. There is often yellow or white fat between the skin and the liver. A normal liver is the same color (or slightly lighter) as a typical animal liver you would find in a market. Under and in front of the liver is a small sac of green fluid. This is the gallbladder.

If you pick up the liver and the intestines, you will find a small ball-shaped organ, the spleen, above the kidneys. The spleen is lighter in color than the kidneys. In the female adult chicken, if it is laying eggs, you will find the spleen to the rear of the lungs and along the back the

ovary, which consists of a mass of egg yolks ranging from microscopic to almost 1 inch in size. The smaller yolks are opaque.

Egg yolks enter a tube through a structure that is called the funnel. The funnel leads to the oviduct, through which the yolk passes and in which the egg white and then the shell are formed—a process that takes about 24 hours. When a hen mates with a rooster, sperm passes through the oviduct system in the opposite direction, and fertilization takes place at the ovary end. Sperm, which may stay viable for up to 4 weeks, are stored in the oviduct.

The best way to learn about the chicken is to go to the market and buy one. If you are not willing to kill a chicken yourself, then have it killed. (If you work with chickens much, you will eventually become accustomed to killing them.) If there are no chickens at the market, buy one from a farmer. Watch the way he kills it. You may want to use the same method used by the farmer. In any case, take the chicken home and try to find all the parts described above. Do this several times until you have learned the parts. If possible, go to a veterinarian for a test, using a male and a female chicken. Don't go to the veterinarian until you have tried on your own several times. If you go too early, all you will do is memorize and forget what is shown to you.

Handling Live Chickens

Now that you have learned some general information about the chicken, it is time to begin learning to handle live chickens. The best way to learn is by experience, and the best chance to get this experience is when a farmer or local veterinary worker is doing it. Find out if there are any poultry-handling activities coming up in the near future, such as the arrival of chicks from a hatchery, vaccinating, debeaking, moving chickens from one house to another, and marketing. (You do not need to worry about these terms now. They are explained later in the manual.) Some farmers, veterinarians, and extension workers will not want you to be involved in these activities; you need to be understanding about their natural skepticism and concern.

Watch others handle chicks. When day-old chicks come from a hatchery, they are usually in a cardboard box or bamboo basket. Pick up a chick with your hand over its back. Do not squeeze—they are very delicate. Hold it as gently as you can without dropping it. Carefully examine the chick. Practice picking it up and setting it down gently. Hold its leg a little to one side and notice how delicate it is. Stretch the wing gently to the side and feel its bone structure. Hold a cup of water in one hand and the chick in the other. Using your thumb and index finger to keep the head of the chick still, practice dipping the beak of the chick in the water. Later, you will find this ability to hold a chick in one hand useful for vaccinations and for giving the chicken its first drink of water.

Ch 3: Overview of Chickens

To hold an adult chicken for examination, hold it at your side, with your middle fingers between the legs and the head of the chicken facing behind you, and the breast of the chicken resting on your arm. Stroke the chicken's back until it calms. Once you are accustomed to doing this, extend your arm out in front of you to get a good look at the chicken's head, neck, and wings. When examining layers to determine the differences between a layer and non-layer of eggs, keep the chicken at your side.

Handle a rooster. Look it over carefully. Find other roosters and compare their appearances. In particular, notice the spurs, comb, and state of health. Feel the breasts of several roosters. In a very thin rooster, all you will feel is a breastbone. Others may be fatter and healthier, with breast meat.

Handle several hens. Ask a farmer to show you one that has laid several eggs during the past week, and some that have not laid any eggs for a long time. Compare the chickens for differences, especially the softness of the skin below the vent, the distance between the bones on either side of the vent (called the keel bones), and the distance between the breastbones and the keel bones. Measure how many fingers you can fit between the keel bones when your fingers are side by side.

When removing older chickens from crates or cages, catch them by their legs and, holding the head in your free hand, take them out head-first. If you take them out feet-first, their wings may catch in the cage opening, injuring the bird. Next, practice holding four or five chickens in one hand at the same time. Do this by adding one after another, holding both legs of each chicken between your fingers, with the chickens' heads pointed straight down toward the ground.

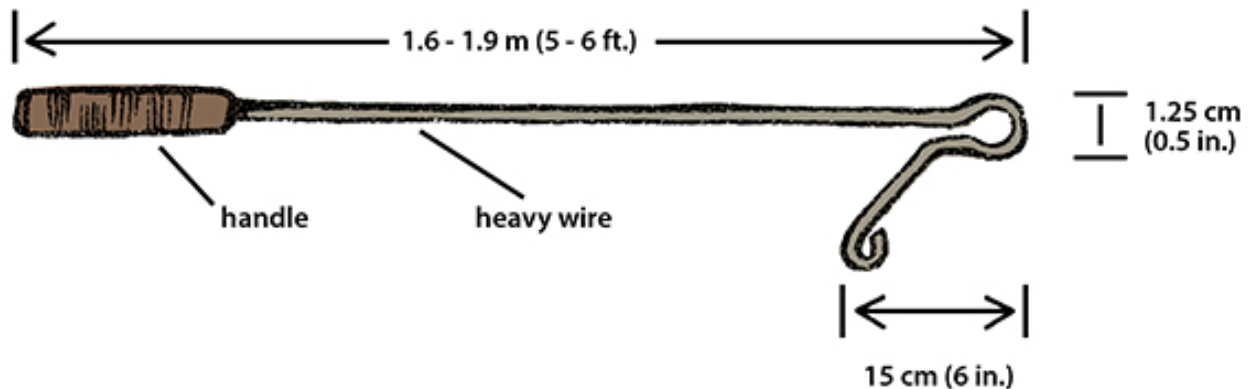
Practice handling and examining chickens of all ages. Notice any differences in weight, feather development, comb size, or other characteristics. If possible, help in vaccinating, debeaking, moving, or any other poultry-handling opportunity that comes up. In all cases, be sure you bathe and wear freshly washed clothes before handling chickens. To avoid any chance of transmitting disease into a poultry flock, bathe and change clothes between visits to different farmers as well. Carry spare shoes to wear when entering a poultry house. Some farmers will not think this is so important; if this is the case, you probably cannot advise them in this regard.

As a rule of thumb, the air space around, below, and above a chicken in a crate should equal the space occupied by the chicken. In hot climates, the air space must be larger. The larger the chicken, the greater the provision for ventilation must be when moving chickens.

Catching Chickens

There are several methods of catching older chickens. One is to use a catching hook.

Figure 3-2: Catching Hook



To use the hook, quietly approach the target chicken from behind. When you are close enough, rapidly hook the chicken's leg and pull steadily toward you.

Another way is to corral the chickens using a framed wire-mesh or bamboo box with hinged corners on three sides and the fourth side open. This box can be used to catch large numbers of chickens, but requires at least two people. Before starting, remove all feeders, waterers, and other equipment from the pen, leaving only the chickens and the litter. Next, corral the chickens as you move the opened box (or catching frame) across the floor. When a number of chickens are inside, close the box. Then you can easily reach in and pick up a chicken.

Now that you know what a chicken looks like, inside and out, and what it feels like, you are ready to read the rest of this manual and use the information that is most appropriate to your situation.

Ch 4: Country Chickens

The country hen is an admirable creature. Through the thousands of years she has lived among humans, she has developed into a self-reliant, disease-resistant, parasite-tolerant scavenger who can survive on almost any kind of vegetable and animal matter that comes her way. She can evade predators, and knows where to shelter when it rains and how to find safe roosts at night. Her eggs, though small, are tasty. Her meat, though tough, is delicious.

For good reason, the country hen is a universal symbol of motherhood. She is eager to set and hatch her eggs, turning them as needed and staying on them continually for three weeks except for very brief forays for food and water. She is such a good mother that she is often used to hatch and care for young ducks and other species of poultry.

The one thing she can't do is produce eggs and meat as well as the improved breeds can. The country hen is geared to produce just enough eggs to ensure the survival of her species. This usually means about 40 to 50 eggs a year, many of which are lost to predators, heat, cold, damp, breakage, and human consumption. If farmers give her good care, she may double her egg production, but she will never reach the levels attained by new breeds.

Why Work with Country Chickens?

Using the country chicken may be the only choice in some areas. Local farmers may not be able to afford the high per-bird investment that new breeds require. The village may be too remote to transport live chicks from a commercial breeder. Vaccines, medications, and the balanced feeds that the improved breeds need may not be available locally. Alternatively, farmers may not want to work with commercial breeds that require so much effort for them to survive and produce.

If this is your situation, don't be discouraged. There are many things that can be done to improve the production of country chickens. However, you must first consider the following factors.

Farmers' Attitudes and Desires

Unless you have the active interest of at least one farmer who wants to improve the flock and is willing to work with you on identifying problems, setting priorities and developing an improvement plan, you won't get very far. Never cast yourself in the role of an expert outsider presenting an infallible plan.

The Effect on the Whole Area

When country chickens run free, they are part of a large, single system. Individual flocks may "belong" to a particular farmer, but they interact with other chickens and thus influence other

farmers' outcomes. For example, if a farmer vaccinates against a disease, it might result in a disease outbreak among other chickens. If some farmers protect their chickens from rats and other predators, the remaining farmers will face increased predator problems. Most likely, all of the chickens in a village compete for the same food sources. If some farmers increase the size of their flocks, will there be enough food?

The Market

In most cases, country flocks are improved to benefit family consumption. Is there room for expansion?

Production Potential

Keep in mind the limits of the country chicken. Do not encourage farmers to spend more money on their flocks than they will receive in benefits from home consumption or sales. You can assume that the average country hen has a production potential of 80 eggs per year, but this does not mean that the five or so hens in a particular small flock will each lay 80 eggs each a year under good management. Individuals and small groups may have a higher or lower potential than average. If there are 100 or more country hens in the area, however, you can use 80 eggs per hen as a goal until your experience suggests a different figure.

The smaller the flock size, the more you must try to reduce the cost of inputs to be on the safe side. Some examples are to:

- Use locally available inputs, especially free inputs, such as harvesting and food processing byproducts.
- Use government programs, if available, such as veterinary services, vaccinations, loans and grants, help with breed upgrading, lower-cost feed, or feed concentrates.

Gathering Information

The best source of information on the current country chicken situation is, of course, the farmers in your area. Local officials and your own observations will be helpful as well. For your area as a whole, you will want to know such things as the number of farmers with chickens, the total number of chickens, the average number of chickens per farmer, the types of management systems farmers use, and any problems that may concern them. This is best discovered by talking with as many people as you can, keeping in mind such questions as:

- Why does the farmer keep chickens?
- How many years has the farmer kept chickens? Did previous generations of the family keep chickens?

Ch 4: Country Chickens

- How many eggs and chickens does the family eat each year? How many do they give away or sell?
- What are the major causes of egg and chicken losses? What protection is given?
- At what time of the year does the farmer think that having eggs and meat available is most desirable, and why? (For example, there is usually a heavy demand for eggs and meat at the end of a religious fasting period in countries with large Islamic populations, and a similar demand for meat for Christmas celebrations in places with large Christian populations. In addition to times of general demand, farmers often can benefit by contracting with local leaders to meet special demands for local celebrations, weddings, and so on.)
- If eggs and meat are relatively expensive food items, when do consumers have the most purchasing power? After harvest season? Does the fishing season have an impact on egg or meat demand?
- When does the farmer or flock hatch chicks, and do they reach production peaks at the time of the year when eggs and meat are most desired? If not, why not?
- How many chicks were last hatched, how old are they, and how many are still alive? Are these the usual totals for a chicken generation? If not, why not?
- Which management techniques does the farmer use and why?
- If the farmer supplements the flock's diet, what foods are used and why?
- Has the farmer had technical advice? If so, who gave it and how?
- Did the farmer follow previous recommendations? If not, why not?
- Who in the family traditionally cares for the chickens (women, men, children)? Were they the ones who received the previous technical advice?
- Are this farmer's responses similar to those of other farmers? If so, do they indicate area-wide problems that need attention first?

Now that you have this information, you should have a broad understanding of poultry in your area. You have made contact with a number of different farmers, and differences in the way they care for their chickens should be evident. In addition, the better farmers may be good future contacts for improved ideas, which are appropriate locally. Now you can look at possible areas where you might focus your poultry development efforts.

Possible Management Improvements

As is often said, almost any operation can be improved. The following are some of the techniques that can be used with country chickens, listed approximately by priority. As you and an individual farmer discuss them, the two of you can work together to begin setting goals and form a plan to meet them.

In addition, study this manual's sections on working with improved breeds. Some of the recommended management practices and equipment can be adapted for country chickens.

Provide Shelter at Night

The country chicken is an independent creature that does not adapt well to a contained system, but it does need nighttime shelter. Overnight shelter probably is the most important possible improvement, because it protects chicks from nocturnal attacks from dogs, cats, rats, owls, and other predators. Even adult chickens can be lost to predators.

Provide Shelter for Chicks

Chicks should be protected constantly until they are at least 4 weeks old. If a brooder (see Chapter 5) or another heat source, such as a box or pen near a kitchen fire, is available, chicks should be separated from the hen about one week after hatching. The sooner this is done, the sooner the hen will lay eggs again.

Build Nests

Set a box or basket lined with straw or other suitable litter in a dark place where the hen can be trained to lay her eggs. To train a hen, introduce her to the nest each morning about the time she usually lays. Put an egg in the nest each morning, using a new one every few days so it doesn't spoil. If an egg is already in the nest, the hen will probably decide that it is a safe place to lay another.

Eggs should be collected every day. A country hen will want to sit on her eggs if they accumulate. If she does, she will become "broody" and stop laying for six to eight weeks, or even longer.

Care for the Chicks

Chicks do not need feed or water for the first 24 hours after hatching because part of the yolk remains inside them. Give them water, but be sure they cannot get into the container and drown. Use whatever materials and food you have available, coming as close to modern management (see Chapter 5) as you can. An adult chicken's production potential depends heavily on the quality of care it receives during early growth stages.

Improve Feed

It is usually uneconomical to feed a fully balanced ration to country chickens. Coming as close as possible to ideal nutrition with available foods can be a challenge. The main considerations are:

Ch 4: Country Chickens

- **Vitamins:** Feed fresh or dehydrated greens (carrot tops, weeds, over-ripe fruits and vegetables, etc.), which are rich in vitamins and contain some minerals.
- **Protein:** The country chicken's diet rarely includes enough protein. Use meat and fish scraps (not rancid), white ants (termites), beans that people won't eat, insects that have been attracted to and killed by a kerosene lantern, and so on. Give priority to chicks and laying hens.
- **Carbohydrates:** Energy is supplied by such foods as broken rice, pressed coconut meat, stale bread, and other scraps.

Provide Health Care

Keep feeders and waterers clean. The shelter should also be dry and clean. Remove old litter and replace it with clean litter every three or four months. Compost the old litter or use it for making methane gas. Follow local recommendations for vaccinations. When possible, use *coccidiostats* (see Chapter 7) mixed in the water supply, as recommended by the manufacturer. However, since country chickens are free to roam, use of *coccidiostats* in the water may not be of any use if other water sources are available. Treat for worms when the chickens are 4 months old and every four months thereafter.

Reduce the Number of Surplus Male Chickens

Surplus males waste feed. Sell or eat them when they are 8 to 10 weeks old, but always keep two roosters in country chicken operations for breeding purposes. Even with small flocks, keep a second rooster in case one dies, unless replacements can be obtained easily and inexpensively.

Upgrading the Flock

Country flocks can be improved or upgraded by introducing roosters from improved breeds. In most cases, the objective of this type of upgrading is to increase egg production. Thus, roosters from improved egg breeds are crossed with the country females. Do not attempt to improve egg and meat production at the same time.

Some governments are attempting to upgrade the national flocks by providing inexpensive or free improved breed roosters. Some breeding operations will sell cheaply or give away egg-breed cockerels (males less than 1 year old) that they otherwise would destroy. Roosters should be about 6 months old when they begin breeding. Be sure that the improved-breed roosters are raised and managed using methods as close as possible to those described in this manual for improved breeds. Vaccinate according to local government recommendations.

To upgrade egg production, use hens that begin laying at a younger age than the area average. Whereas most country hens start laying at 26 weeks, improved breeds begin at 21 weeks. This means that country hens eat valuable feed for an extra month before producing. Direct observation and good records should identify the early layers. Select hens that lay the most eggs during the first four months of laying and whose sisters and mothers also are good layers. Farmers may be able to identify good laying families with high survival rates.

Only healthy hens should be used for breeding. The ideal time for breeding is immediately after the first four months of laying, when the hens have demonstrated that they are good layers. After a hen has been laying for a year, her eggs will have a lower rate of fertility. Remember that all eggs from superior hens are better than other eggs.

Isolate breeding hens from local roosters. In some countries, the government advises destroying all country roosters in the area. If local roosters get at the selected hens, you are back to where you started.

Box 4-1: An Example of the Expected Result of Upgrading

Country hen: Laid 100 eggs last year, beginning at 25 weeks. Sisters and mothers produced about the same.

Improved rooster: Breed potential of 245 eggs a year. Layers of the same breed begin to lay at 21 weeks.

Result: Cross-breed pullet that begins laying at 24 weeks, with a potential of 130 to 150 eggs per year.

The more generations upgraded, the higher the potential. However, each generation's potential will increase at a slower rate and need more intensive care and balanced feeds. If members of an upgraded flock mate with one another, potential production will eventually fall to pre-upgrading levels.

For upgrading meat production, simply use improved meat-breed males instead of the egg-breed males.

Farmer Assessments

You may find it useful to prepare a simplified version of the farmer assessment worksheets in Appendix C. In your talks with a local farmer, the two of you can review the worksheet, find the biggest gaps in production, and plan how to fill the gaps to improve production of country chickens.

Ch 5: Poultry Husbandry

This chapter deals with raising the improved breeds of chickens. Even if this chapter were many times its present length, it could not offer all the information a dedicated farmer needs to provide the best care for new breeds. Good use of other information sources and accumulation of local experience will help you fill this gap.

If farmers are interested in trying the new breeds, or if they are already raising them and want to improve their operations, this chapter provides some essentials to consider. The most important are:

- **Individual interest and commitment:** In raising any livestock, there is no substitute for tender loving care. To do well with the new breeds of chickens, a farmer must understand their needs, be ready to provide the daily attention they require, and understand that small details may mean the difference between success and failure.
- **Management system:** This manual recommends using a fully contained system for the new breeds. Local considerations may influence this decision, but in general, a well-run, fully contained system has the highest profit potential. However, this means that the birds rely completely on the farmer for all of their needs.
- **Eggs or meat:** It is best to concentrate on producing either eggs or meat, not both. Selection of the main product depends on the local market and the types of breeds available. Some families, fully occupied with crop production during certain seasons, may find that an 8- to 10-week cycle of raising meat chickens fits the time they have in the off-season.

Breed Source

Far too many breeds and breed combinations exist throughout the world for this manual to discuss them in any detail. The number of new breeds available in a developing country is usually very limited. Although chicks can be transported from other countries by air, that process is expensive, and delays or other problems along the way can kill the chicks.

If people in your area have worked with improved breeds, their experiences will be helpful in selecting a breed. If no one nearby has such experience, you can try to find successful farmers in other areas. Try to pick areas that are as similar to yours as possible in social structure, climate, altitude, and water and feed availability.

If you cannot get advice from experienced farmers, you will have to rely on the recommendations of commercial breeders or government breeding farms. Know as much as you can about your area's characteristics before you talk to breeders. Chicks from the best-producing breeds will probably yield the highest prices, but this is a very small part of your total costs—it is usually unwise to try to save money here. All things being equal, the most desirable breed is the one that lays the most eggs or produces the most meat per unit

of feed. Other considerations are the breed's hardiness, adaptability to your area, selected management system, and—most importantly—acceptability among local farmers.

Layer Breeds

The basic decision is between breeds that lay white eggs and those that lay brown ones. Although there is no nutritional difference between white and brown eggs, people in your area may have a strong preference for one color. This preference should be considered. Good layers usually begin producing when they are 21 weeks old and continue for 12 months, laying about 250 eggs during that time.

White Eggs

The most popular white-egg breed is the White Leghorn . It is smaller than other breeds and produces the most eggs per unit of feed eaten; thus, it has a higher profit potential. Generally, the best producer is a hybrid White Leghorn, but special breeds or crosses may have been developed in your area to meet local conditions.

Distinguishing features of the White Leghorn include white feathers and earlobes. (Not all white egg layers have white earlobes.) Adult females weigh about 2 kilograms (4.4 pounds), and adult males weigh about 2.7 kilograms (6 pounds). White Leghorns are known to be quite nervous and flighty, but with proper care, they are excellent egg producers.

Brown Eggs

Rhode Island Reds and New Hampshires are two popular brown-egg breeds, but there are many others. These breeds are heavier than White Leghorns. Some lay as many eggs as White Leghorns, but they eat more feed per egg produced. Their eggs vary in color from light beige to dark brown;

Distinguishing features of Rhode Island Reds and New Hampshires include red earlobes and feathers that vary from almost white to red, brown, black, or a combination of these colors. Adult females weigh about 3 kilograms (6.5 pounds); males weigh about 3.6 kilograms (8 pounds). Some of the newer crosses weigh much less at maturity.

Ch 5: Poultry Husbandry

Figure 5-1: Popular Breeds (Rhode Island Red, White Leghorn, New Hampshire)

Photos c/o creativecommons.org



Meat Breeds

A popular improved meat breed is a cross of a White Rock (a heavy breed) with a medium-weight breed, such as a Cornish, or sometimes another White Rock. Present-day meat strains are known as “synthetic breeds” and are the result of crosses involving White Rocks, Cornish, Barred Rocks, and other breeds. Mature adult females weigh about 3.6 kilograms (8 pounds); males weigh about 4.5 kilograms (10 pounds). They should be kept only until they are about 8 to 12 weeks old, when females weigh about 1.8 kilograms (4 pounds) and males weigh about 2.3 kilograms (5 pounds). In 10 weeks, these breeds reach almost the same weight that egg breeds reach in 20 weeks. Meat breeds also have more meat per unit of body weight than egg breeds. Some breeds with dark feathers also have dark skins—a feature that many consumers do not like. If no meat breeds are available in your area, it might be economical to use males from the heavier brown-egg breeds for meat production.

Dual-Purpose Breeds

Generally, these breeds are used to produce eggs; their meat is a secondary consideration. If you are concentrating on producing eggs, evaluate these breeds as you would layer breeds. If meat production is the objective, the choice will be more difficult, because it will be expensive to keep poor-laying hens to maintain the flock. When the specialized meat and egg breeds are available, it is almost always wiser to select one of those.

Starting a New Flock

Obtain eggs from a neighbor or a commercial source, or use eggs from a current flock. Be sure the eggs are no more than 7 to 10 days old and have been kept continuously cool. They will be hatched by either a broody hen or an incubator (see the section on incubation, below).

Day-Old Chicks

Most countries have commercial hatcheries that supply day-old chicks. Chicks should be kept in warm, humid conditions while being transported to the farmer. If possible, people at the hatchery should vaccinate the chicks for Marek's and Newcastle diseases before shipment. Chicks should be from a breeder that is free of *Salmonella pullorum* disease. Plan to have the chicks arrive at the best time of the year and when equipment and supplies for them are already ordered. Chicks may take several months to arrive, and may come in one of two ways:

- Straight run, or unsexed: Straight-run chicks have not been examined to determine their sex. This is the way all but specialized layer breed chicks are sold.
- Sexed: An expert examines the chicks and disposes of most males. This process is about 95 percent accurate, so expect a few cockerels in the flock.

If you cannot buy sexed chicks for a layer flock, unsexed chicks will do. With heavier breeds, males can be raised as meat birds. With smaller breeds, such as the White Leghorn, it is best to eliminate all males as soon as you can recognize them (anywhere from 3 to 8 weeks, depending on the breed), unless you want to isolate and keep a few for breeding. Layers do not need roosters around to produce eggs; in fact, the presence of males may lower production.

Started Pullets

Young hens (4 to 6 months of age) that are about to start laying or have already started are called *started pullets*. They will cost much more than day-old chicks, but they begin to produce as soon as they arrive, and the farmer saves the time and equipment needed to incubate eggs or raise chicks to laying age. Started pullets should be examined very closely for parasites and signs of disease. Know as much as possible about the hatchery's management methods: have the pullets been fed properly, vaccinated regularly, and otherwise well cared for, and do they come from good stock?

Started pullets may come down with coccidiosis, because the farm where they came from may have different prevalent strains of coccidia than your farm does. Coccidia are present everywhere but the different strains are not distributed evenly; immunity to one strain does not guarantee immunity to the others.

Ch 5: Poultry Husbandry

Hatching Chicks

To have more chicks you will need a rooster to fertilize the eggs. One rooster is enough for 5 to 15 country hens. If you can obtain one, consider using an improved rooster to produce progeny with the disease resistance of the country chicken and some increase in egg or meat potential.

Three or four days after a healthy rooster is introduced, the eggs laid should be fertile if the rooster and hens are good breeders. Fertilized eggs for hatching can be kept cool in a clay pot as described in the marketing section of Chapter 9. Eggs can be kept in the pot up for to five days. If refrigeration is available, eggs can be kept for up to 10 days at 15.5°C (60°F). Use clean eggs—if possible, from several hens, because not all hens will produce fertile eggs. Eggs should be of average size, normal shape, and without cracks.

Select or develop a broody hen. In general, hens from improved breeds won't do, because "broodiness" has been bred out of them. Pullets (females less than 1 year old) often do not make as good mothers as older hens do. A broody hen ruffles her feathers, stays on her nest, and will return to it quickly if removed. She is not as docile as usual and will peck your hand if you try to move her or take her eggs. If no hens are broody when you need one, you can try to develop one by setting three or four eating eggs on a nest in a small pen in a quiet location that is protected at night. Put a healthy hen (the fatter, the better) on the nest at dusk. Do this every evening until she becomes broody. If it takes more than three days, provide new eggs and eat the old ones. Always keep water and feed in small containers just out of reach of the nest in the brooding pen.

When you have a broody hen, treat her and the nest for lice. Set about 10 to 15 fertilized eggs under her (the number of eggs she can cover depends on her size). The sooner the eggs are set for hatching after laying, the better the hatch will be. You should expect seven or eight chicks from 10 to 15 eggs, half of them female and half male.

Keep the hen confined to the brooding pen day and night, allowing her out to eat and exercise at dawn and at 2 p.m. for about 20 minutes each time. Do this at the same time every day throughout the incubation period. She will become accustomed to the routine and will be upset if it is changed. While she is out, clean any feces from the nest and provide fresh water. The water container should be attached to the side of the nest box so she cannot tip it over. In very dry climates, it may help to sprinkle a little water on the litter under the eggs, although never on the eggs themselves. In most cases, the hen will turn the eggs and keep them moist by herself.

Occasionally, a brood hen will refuse to leave the nest to eat. In this case, carefully lift her straight up off the eggs, making sure she doesn't have any tucked between her wings and body, and put her out. Let her back in or put her back 20 minutes later.

On the seventh day of incubation for white eggs (the tenth day for brown eggs), you can use a candle to test eggs for fertility while the hen is out. Remember that there may be a delicate embryo inside, so handle eggs carefully. Remove all eggs without embryos, and those that have cracked shells or malformations.

On the twenty-first day of incubation, chicks should begin to hatch. Do not disturb the hen on the nest until the hatching period ends in the evening. At that time, remove all unhatched eggs and broken shells. Dispose of weak chicks that can't free themselves from the shell; they will never thrive. Provide clean litter for the nest. At this point, the chicks are ready for brooding.

Incubation

For small numbers of eggs, one or more broody hens will do the job nicely. If there are no broody hens around, or if you want to hatch more eggs, you will need to incubate the eggs artificially.

The main reason you to incubate eggs is to produce chicks that, when grown, will bring greater returns than chicks that could be obtained elsewhere. Other reasons could include incubation for educational purposes or unavailability of chicks from other sources. Successful incubation requires these basics:

- A selection of clean, fertile eggs
- A source of heat
- A means of humidity control

More specifically, clean, fertile eggs are from hens ideally between the ages of 8 and 18 months. These hens and, if possible, sisters, brothers, and parents of these hens, should have the characteristics desired in the chicks. Since one hen may produce infertile eggs, use eggs from several hens. In order for eggs to be fertile, a rooster must have access to the hens for at least four days prior to collection of eggs for incubation. The sisters, brothers, and parent generations of the rooster should also have the desired characteristics, such as a history of high egg production, rapid growth rates, resistance to disease, or egg size.

The more factors you select for, the slower the progress will be. For more rapid progress and simplicity, the following steps are recommended:

- Step 1: Acquire roosters from an improved breed. Since most commercial breeders destroy the males of egg production flocks at the time of hatching, a commercial breeder is an ideal source of roosters. They will be 1 day old when you get them.
- Step 2: If possible, find out from farmers which country chickens lay the most eggs.
- Step 3: Cull all males in the village except those of improved breeds.

Ch 5: Poultry Husbandry

- Step 4: Two weeks after the unwanted roosters have been removed from the village, begin saving eggs for hatching.

The cross of a country chicken, which averages 60 eggs per year, with an improved male whose sisters lay 250 eggs, will bring excellent results. The daughters will lay 100 or more eggs if kept properly, and will have nearly the same disease resistance of the country chickens. If kept under ideal conditions, they may lay 125 to 150 eggs per year.

Egg Selection

Selection of good eggs for hatching is important. First priority should be given to eggs from hens between 8 and 18 months of age, because the size, interior, and shell quality of eggs from this age group is most likely to be good for hatching. Next, look closely at the shell. Eliminate any eggs that are cracked, dirty, or misshapen. The best way to determine which are typically shaped is to lay 20 or so eggs on a table.

Figure 5-2: Egg Selection



1. Eliminate eggs that are nearly the shape of a ball:



2. Eliminate eggs that are nearly the same size at both ends:



3. Eliminate eggs with uneven shell structure:



4. What you have left should look like this. The egg may have some specks (calcium deposits) on the outside. This is all right if the individual specks are smaller than the period at the end of this sentence.

Bacteria on eggs will penetrate the shell within 2 to 5 hours after the egg is laid. Clean eggs can be sanitized by dipping them in a chlorine solution (500 parts chlorine per million parts of water) at 40.5°C (105°F). Do not use iron metal dipping baskets or containers because they will leave a rust residue on the eggs. Quaternary ammonia is quite effective as a disinfectant. Use 500 parts per million and dip eggs into a solution that is warmer than the eggs. In either case, remove the eggs from the solution and do not handle them until they are dry.

Incubator Management

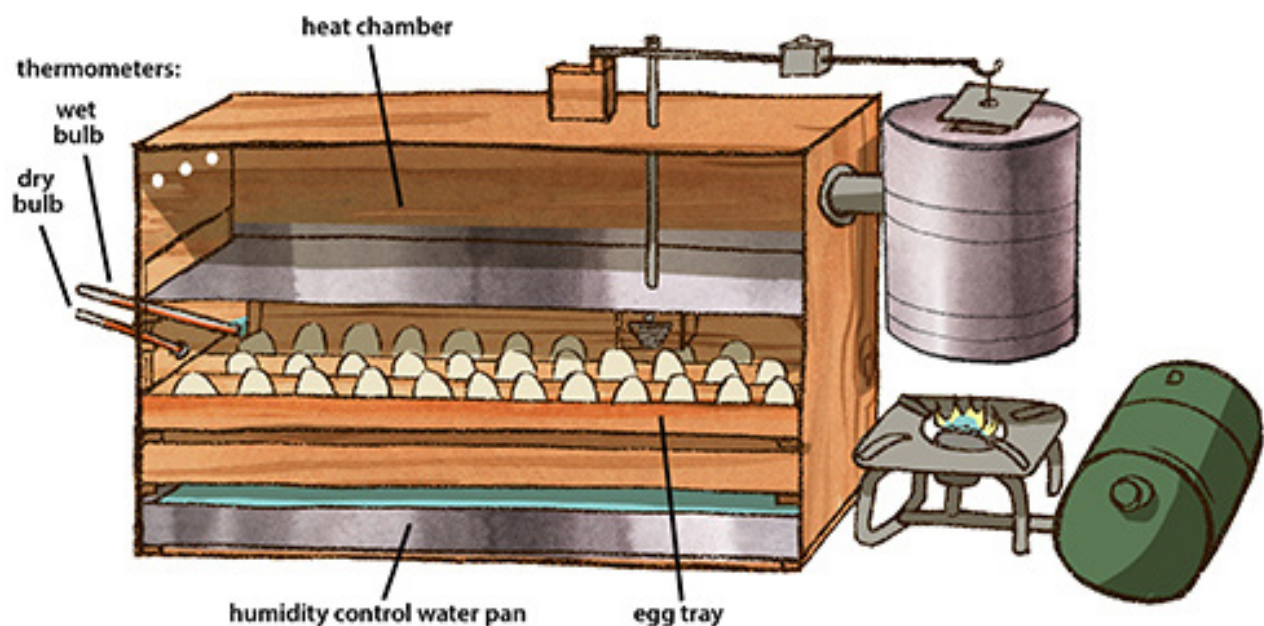
A hen on a nest of eggs provides constant body heat and moisture and turns the eggs frequently. Good artificial incubation mimics conditions in a nest.

Ch 5: Poultry Husbandry

A good incubator is an insulated box with a heat source that can be regulated, a thermostat, and a high-quality, easy-to-read thermometer that shows fractions of degrees accurately. Ideally, an incubator should also have a small glass window to allow you to read the thermometer and a means of measuring and controlling humidity. Provide a tray filled with water to generate the necessary humidity, and use a wet thermometer to measure the humidity. A “wet” thermometer is simply an ordinary thermometer with its lower end inserted in water, or a thermometer placed above a source of water with a piece of cloth wrapped around the end of the thermometer and the bulb placed in the water.

The incubator should also have some means of adjustable ventilation.

Figure 5-3: Kerosene-Heated Incubator



Thoroughly clean the incubator with a strong disinfectant before use. **Warning: do not use phenol, coal tar, or pine tar to disinfect an incubator.** When heated, these residues release fumes that can kill embryos and chicks.

Once you have built or bought an incubator, run it empty for at least three days to practice regulating the temperature, keeping it between 37.8 and 38.3°C (100 to 101°F), before you place hatching eggs in the incubator.

The incubator should be in a well-ventilated but not drafty room. Once the internal temperature is 37.8°C (100 to 101°F), place the hatching eggs inside. Pencil an “X” on the

upper side of the eggs. Place a tray of water inside or fill the receptacles provided in the incubator, and keep them filled.

Turning the eggs prevents the embryos from sticking to the shell lining. The eggs should be turned at least once every 8 hours, but shorter intervals are better. Turn the eggs an odd number of times each day so that the position of the eggs is alternated at each long night interval. Remove the tray, closing the incubator door so no heat is lost. Use the penciled "X" as a guide to rotate the eggs 180 degrees. If the tray is square, rotate it one-quarter turn each time you turn the eggs. This will help balance the effects of uneven temperatures on different sides of the incubator. Keep an accurate record of the temperatures, time of each turning, and which numbered side of the tray is in front.

On the seventh day of incubation for white eggs (tenth day for brown eggs), you can use a candler to test the eggs for fertility. When handling the eggs, remember that there may be a delicate embryo inside. If there is no embryo, the egg may be edible, provided that the air space in the egg (which the candler will reveal) is no larger than 9 millimeters (3/8 inch). The size of the air space will also help gauge the humidity in the incubator.

If the air space is larger than shown, increase the water surface area available for evaporation; if smaller, decrease the water surface area.

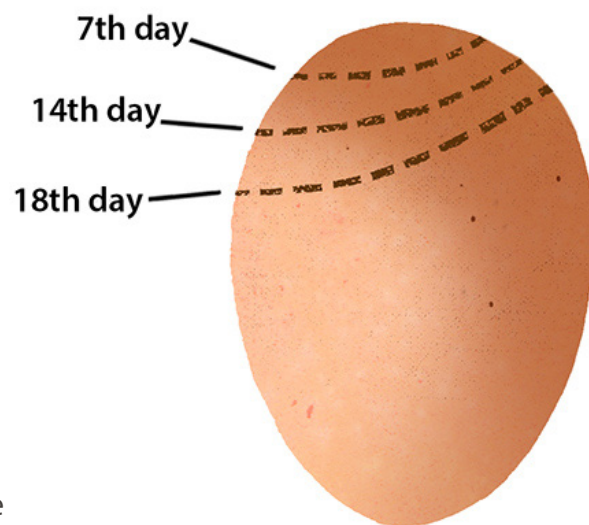
Edible or not, remove all eggs without embryos and any with cracked shells. Increase the temperature to 38.9°C (102°F).

On the eighteenth day, double the water surface area available to increase humidity. Open all incubator vents for maximum air circulation.

On the nineteenth day, and for the next three days, do not open the incubator (except to check the temperature, if there is no viewing window). Decrease the dry bulb temperature to about 99°F.

On the twenty-first day, the chicks will begin to hatch. Ideally, all chicks should have completed hatching exactly 21 days and 6 hours after setting in the incubator. Some chicks may not hatch until later in the day; these late chicks have been shown to be genetically inferior to those that hatch on time. After 21 days and 6 hours, you should open the incubator

Figure 5-4: Size of Air Space

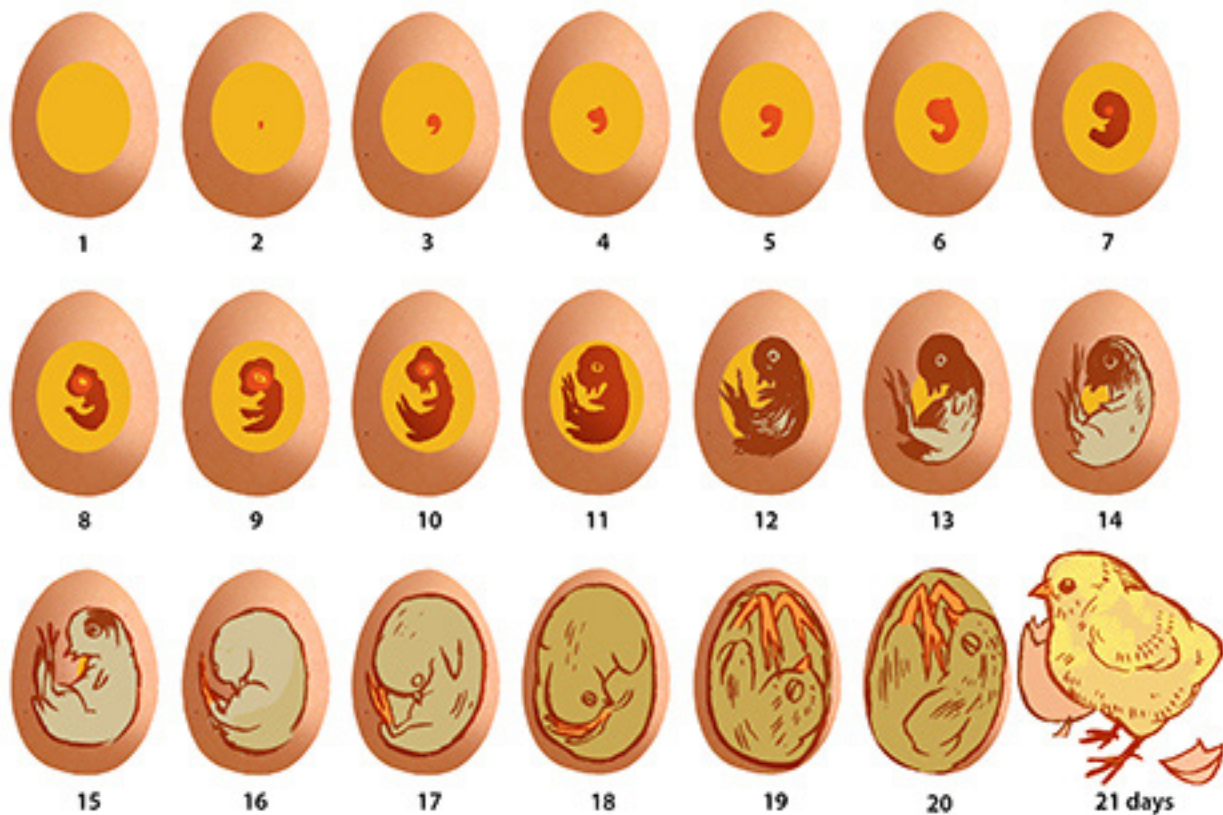


A candled egg showing normal air space during incubation.

Ch 5: Poultry Husbandry

and remove all broken shells and unhatched or incompletely hatched eggs. If the incubator has more than one tray, distribute the chicks evenly in the trays and gradually reduce the temperature to 35°C (95°F). Remove any shell fragments stuck to the chicks. At this point, the chicks are ready for brooding.

Figure 5-5: Twenty-One Days of Chick Development



Candling Eggs

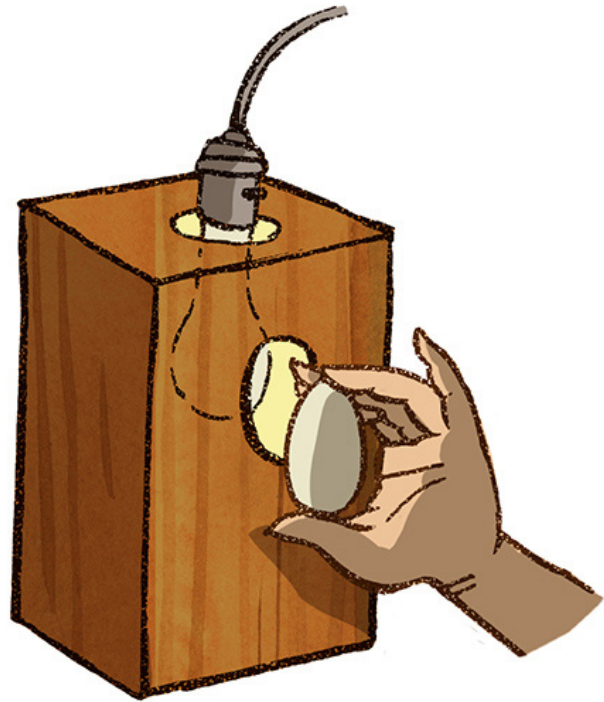
You can get a good view of an egg's interior by using an egg candler. A candler encloses a light source in a case or box with light shining through a hole 3 centimeters (1 1/8 inches) in diameter. Usually the light source is a 25- to 60-watt light bulb, but you can use a slide projector, a powerful flashlight (electric torch), or even an actual candle.

Use the candler in a darkened room. Turn the eggs quickly in the light so the contents rotate, and look for:

- Embryos: Thin blood vessels emerging from a dark red spot mean the egg has been fertilized and the chick has started developing.
- Cracked shells: The candler will reveal cracks that cannot be seen otherwise.

- Shape and movement of yolk: Yolks noticeably out of their usual central position, stuck to the shell, uneven in color, or of abnormal shape indicate poor-quality eggs.
- Blood spots: Although blood spots in eggs are harmless, many people find them unappetizing, so don't market eggs that contain them.
- Discolored whites: Clouded or streaked whites reduce egg quality.
- Size of air cell: An air cell more than 1.25 centimeters (1/2 inch) deep may indicate a bad egg.
- Mold or rot: Various colors on or in the egg, or its smell, are signs of moldy or rotten eggs.

Figure 5-6: Using a Candler



Always wash your hands before handling hatching eggs.

Brooding Chicks

Small numbers of chicks can be given to a broody hen. After she has set on a few eggs for at least two or three days, she should accept the chicks. In the evening, slip a few chicks under her and, if she doesn't reject them, give her the rest and remove the eggs.

If there is no broody hen about, or if there are more than a dozen or so chicks, they will have to be brooded artificially. This is a critical time in their lives: they must be kept warm and have water available at all times.

Preparation

If the house and equipment have been used for chickens before, older chickens should be removed at least one month before the chicks arrive. To avoid disease, do not mix groups of chickens, especially chicks and older birds. Remove all feeders, waterers, nesting boxes, hoppers, roosts, and other equipment from the house. Wash these items, leaving no visible dirt, clean with a strong disinfectant, and rinse with fresh water. If possible, let them dry in the sun.

Ch 5: Poultry Husbandry

Remove all old litter from the house. Sweep the walls, ceiling, and floor to remove dirt and dust, and then scrub with water and disinfectant. Make any necessary repairs to the house and equipment. Spray the house with a safe insecticide if ticks, lice, or mites have been a problem. **Warning: Be very careful when using any type of insecticide, which can be dangerous to humans and chickens if used improperly.** Check with local authorities to determine which insecticide to use, and follow their directions carefully.

On the following day, wash the walls and floor with a 2 percent solution of a mild disinfectant, if available; otherwise, use water. The house and equipment should have at least two days to dry out. Spread litter 5 to 10 centimeters (2 to 4 inches) deep on the floor. Depth of litter depends on its moisture-absorption capability. If sawdust is used for litter, cover it with paper during the first three days so the chicks don't eat it. Sawdust can cause problems in the digestive systems of young chicks. Replace the equipment and install and test the brooder at least three days before the chicks arrive.

Any organic material that absorbs moisture can be used for litter. Of course, availability and cost must be considered. Possible litter materials, ranked approximately by absorption capacity, include:

- Peat moss (usually very expensive, if available at all)
- Chopped oat straw
- Softwood chips
- Hardwood chips
- Chopped rice straw
- Chopped wheat straw
- Softwood, sawdust (only after 4 weeks of age)
- Hardwood sawdust (only after 4 weeks of age)
- Shredded maize (corn) stalks
- Rice hulls
- Groundnut (peanut) shells
- Shredded sugarcane stalks
- Dried pineapple waste
- Coffee hulls
- Ground maize (corn) cobs, shucks, or husks (note: may present mold problems)
- Broadleaf leaves (note: may present mold problems)
- Sand (use as a last resort)

Watch for mold in litter; most good litter materials are also good mediums for mold due to their water-retention characteristics. Any straw should be well-dried in the sun before it is used as litter. Chopping the straw, though difficult, increases its usefulness because it absorbs more moisture and can be turned more easily than unchopped straw.

NOTE: Do not use fine grass straw. The chickens may eat it and some may be caught or bound in their crops. The crop of a chicken that has eaten a substantial amount of straw will feel hard. More often, there will be only a few pieces of straw caught on the lower end of the

Ch 5: Poultry Husbandry

crop. If the chicken then eats and drinks normally, feed and water will be clogged above the straw. The result is a large, soft, and mushy crop. There is no practical cure for a crop-bound bird; it is best to eat it.

Start with a litter depth of about 7.5 to 10 centimeters (3 to 4 inches), depending on the absorptive capacity of the material, and increase it gradually until it is about 15 to 20 centimeters (6 to 8 inches) deep at the end of a laying cycle. Do not let litter get packed down; turn it frequently—every day in humid climates. Replace wet litter immediately. Add powdered lime to moist litter to help dry it. In dry litter, enough heat builds up to kill most bacteria, worms, and fly larvae.

Heat Source

Brooders are used in place of brood hens to keep chicks warm and protect chicks from wandering. As a heat source, use either a kerosene lamp with wire around it (to keep chicks from crowding next to the hot glass) or an electric light bulb. Charcoal stoves have to be tended too frequently to be practical.

A hover is a hood that retains and distributes heat evenly. It can be made of wood, woven bamboo, or sheet metal, and either placed on legs or hung from beams. When using any heat source other than electricity, the hover should have a vent on top to allow fumes to escape.

Figure 5-8: Light-Bulb Brooder Suitable for about 50 Chicks

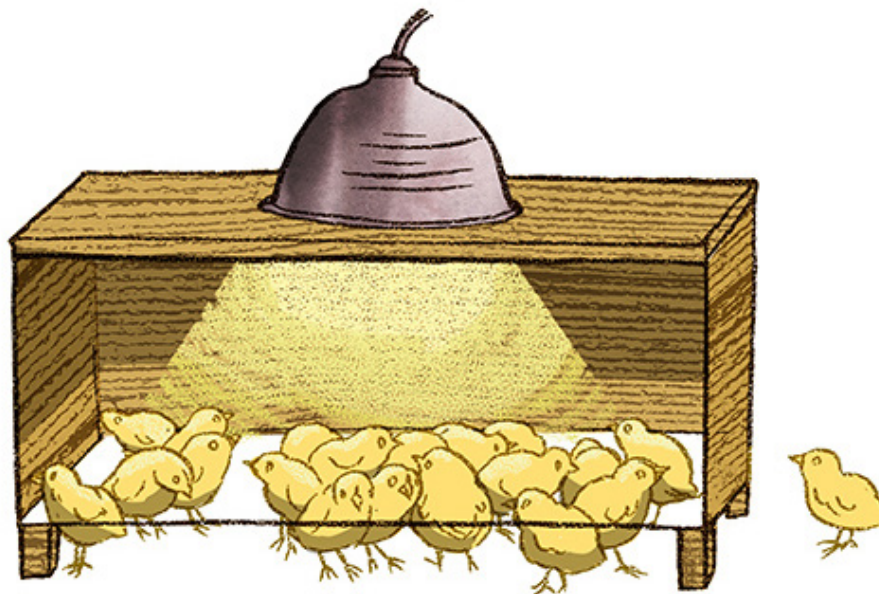
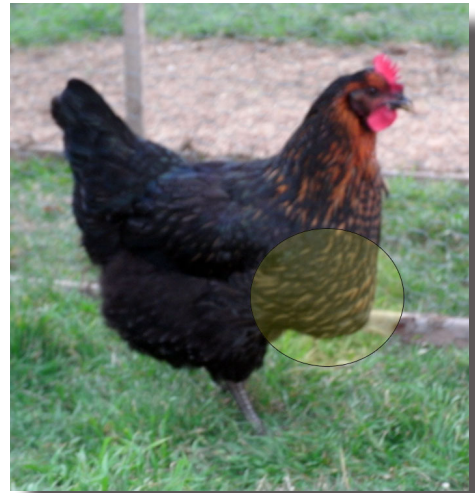


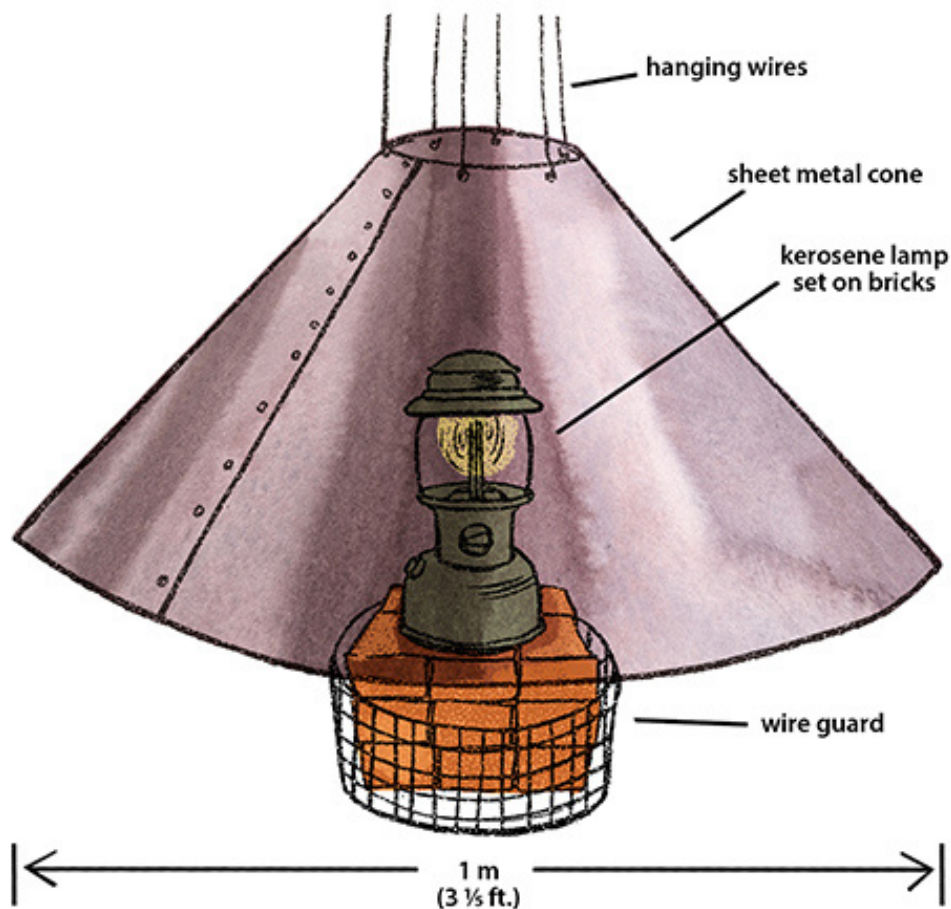
Figure 5-7: Crop-Bound Chicken

Photo c/o creativecommons.org



Ch 5: Poultry Husbandry

Figure 5-9: Colony Brooder Suitable for 100 Chicks



Place litter underneath and distribute feeders and waterers evenly. Electric light bulbs (200 watts) can be substituted for kerosene lamps. **Note: Brooders are a major cause of chicken-house fires.** Kerosene lamps—especially those near dry litter—must have a solid, level base, and careful handling is necessary to avoid spilling kerosene.

Other heat sources include solar heat and wood chips. If solar heat is used, there must be a means of heat storage, such as a water tank, sand, or rocks. This storage is necessary to maintain warmth at night.

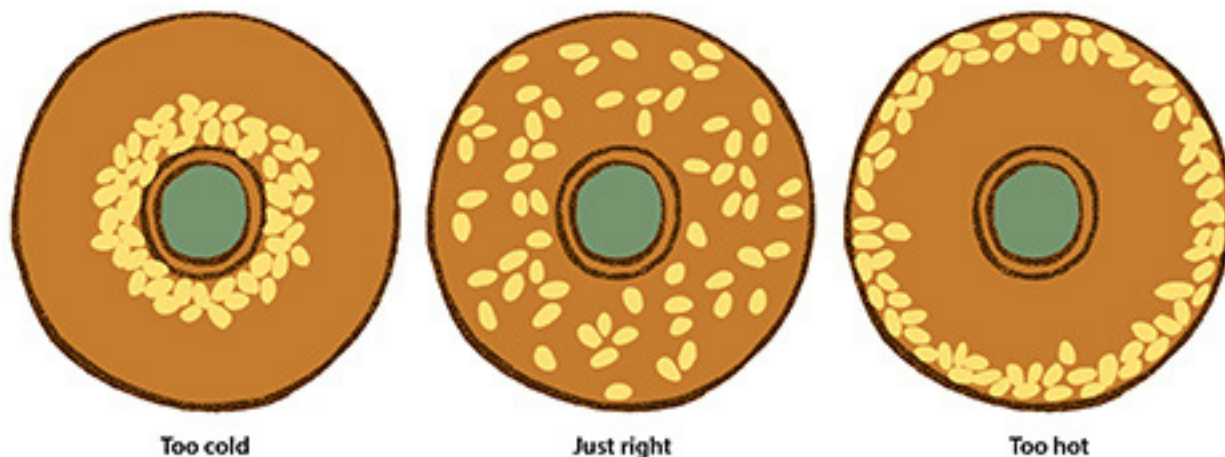
Figure 5-10: Basket Brooders



A temporary fence outside the hover area is called a brooder guard or chick guard. A brooder guard keeps the chicks near the hover, but allows them to get away from excessive heat. It usually is made of solid material, such as cardboard, to reduce floor drafts. It has no corners where chicks can pile up and smother. As the flock grows, the brooder guard should be expanded.

Read temperature 5 centimeters (2 inches) from the floor and 30 centimeters (1 foot) from the heat source. Start the brooding at 35°C (95°F) for the first week, and then reduce the temperature by 2.8°C (5°F) each week by adjusting the heat source or height of the hover.

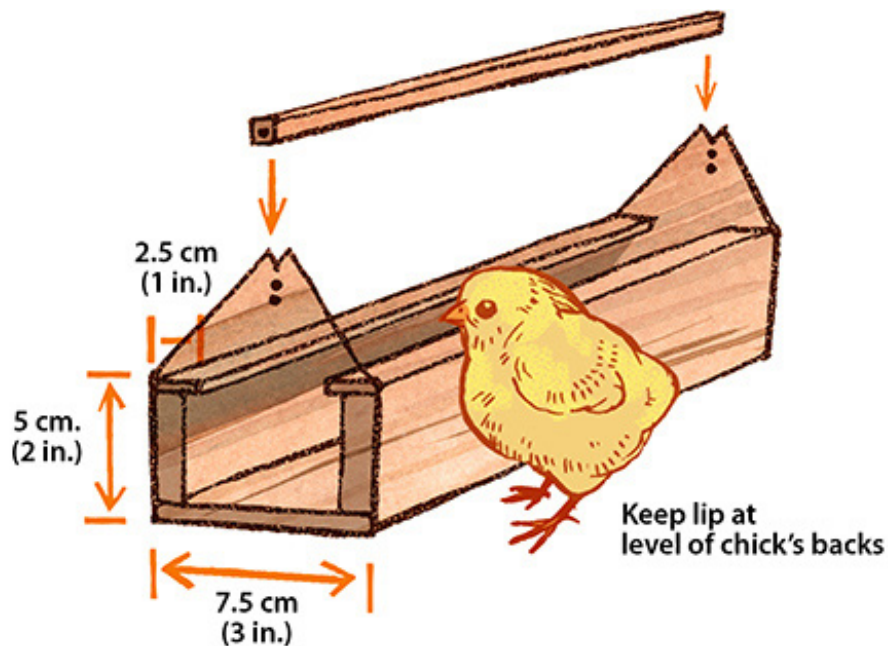
Figure 5-11: Top View of Chicks Distributed around a Brooder Heat Source



The first few days, chicks will pick at anything; they cannot tell a feeding area from the rest of the floor, so it is wise to have feed scattered over a large area. Put newspaper or cut cardboard boxes down on the floor and scatter feed on them to supplement the chick-sized feeders.

Ch 5: Poultry Husbandry

Figure 5-12: Chick-Sized Feeder



For their first three weeks, 100 chicks will need about 2.5 meters (100 inches) of feeding space. Four feeders, each 33 centimeters (13 inches) long, should be enough.

For 100 chicks, use four waterers made of small clay jars, tin cans inverted in saucers, or the bottoms of larger tin cans. Increase the number and size of waterers as the flock grows. Because chicks drown easily, openings in waterers must not be large enough to allow chicks to fall or be pushed into the water.

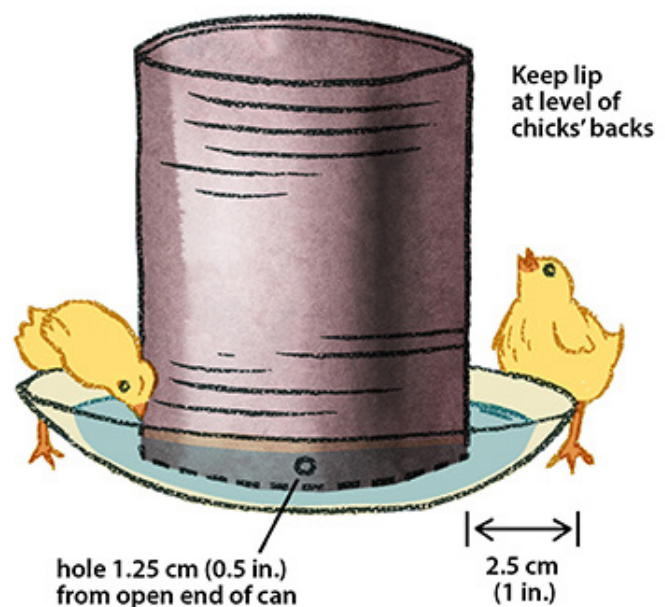
Place waterers on flat boards and keep the area around them dry.

Chickens need water every 15 to 20 minutes. They must have a continuous supply of fresh, clean water if they are to do well. Change the water at least once, and preferably twice, each day.

Keep waterers as clean as possible and replace rusty ones.

Distribute waterers evenly throughout the house. During their first week or two, no

Figure 5-13: Chick-Sized Waterer



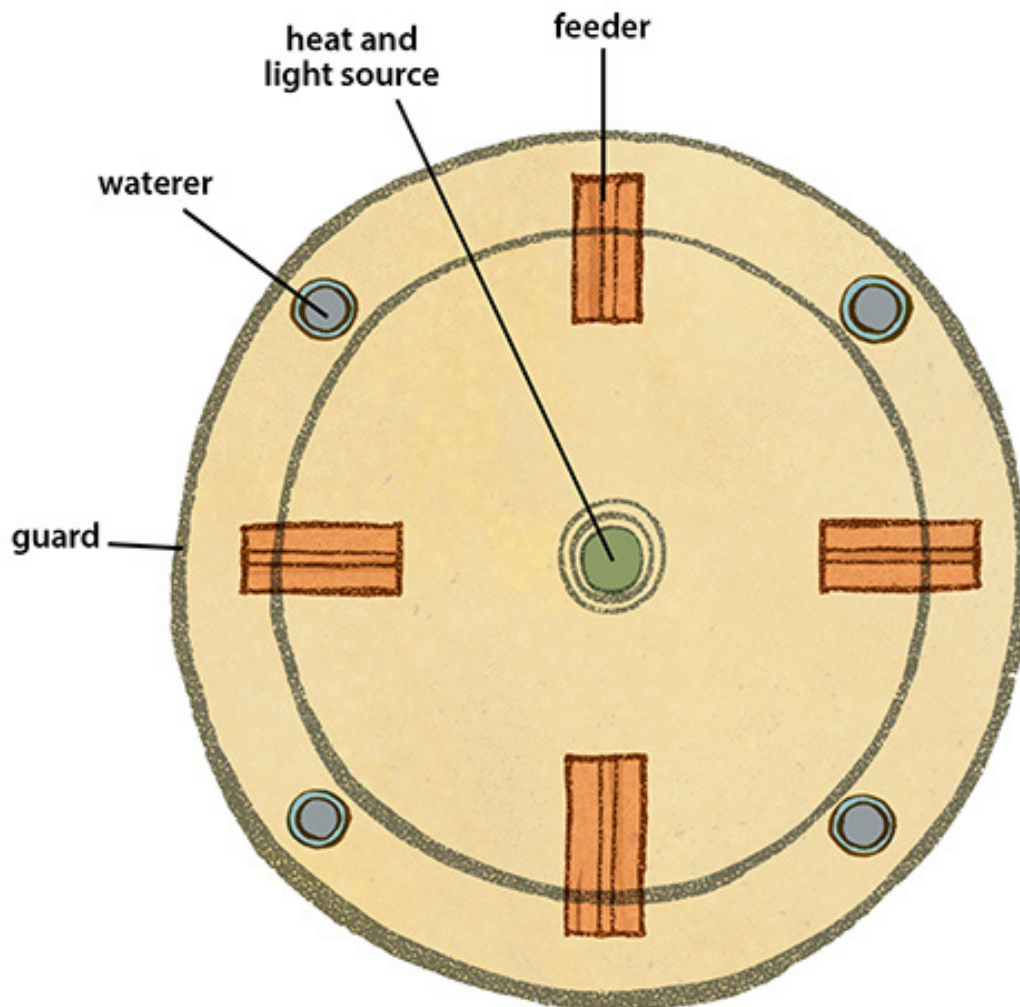
chicks should be more than 1 meter (3 feet) from a waterer, and not more than 3.5 meters (10 feet) thereafter.

Disease can spread quickly when water is spilled on litter. Keep the area around waterers dry and clean. It is better to place the waterers on flat rocks, bricks, or slatted or wired platforms than on litter. Remove and replace wet litter as soon as possible.

Placement of Brooding Equipment

Distribute brooding equipment evenly under the hover to give all chicks a good chance to eat. Change the position of waterers and feeders often to keep litter clean and dry.

Figure 5-14: Layout of Brooding Equipment



Ch 5: Poultry Husbandry

Brooding the Chicks

A few hours before the chicks arrive, put clean water in the waterers, completely fill the feeders, and put some feed on the paper or cardboard. The temperature under the hover should be 35°C (95°F).

When the chicks arrive, count them and dip each chick's beak into a waterer to be sure that it gets a drink. Vaccinate them for Newcastle disease if this hasn't been done. **(Note: Check with local authorities for all vaccination recommendations and schedules. Before vaccinating chickens against any disease, get approval from the appropriate government ministry. If you vaccinate for a disease that is not present in your area using live serum, you may introduce that disease instead of protecting against it.)** Watch the chicks for at least two hours. If any are obviously ill, remove them. The chicks' behavior will tell you whether the brooder temperature is correct. If they huddle close to the heat source, it is too cold; if they crowd the brooder guard it is too hot! Check the distribution of the chicks and see that they have feed and water often—every three hours for the first 24 hours, including the night.

During the brooding stage, chicks will eat through the night because light is available continuously. They should never be without feed for more than 30 minutes at a time (the same is true for mature birds during daylight). If recommended by local authorities, the feed should contain a coccidiostat.

Spend time every day just observing the flock. As they grow, see if they are all about the same size and are putting out feathers at about the same rate. If so, the chicks probably are healthy, from good stock, and receiving good feed. Watch for any inactive chicks. Those that stand still for more than 10 minutes are most likely sick.

On the third day, allow the chicks to finish the feed in the feeders. From then on, fill the feeders half full. If chicks are eating well, remove the paper or cardboard.

For the rest of the chickens' lives, completely change their water every day at dawn and in the early afternoon, rinsing the waterers out as you do so. Chickens should have water available at all times.

On the fourth day, begin looking for signs of coccidiosis. If there is a serious outbreak, take immediate action. Be alert for coccidiosis until the flock is at least 12 weeks old. On the sixth day, be sure that there is grit in the feeders. From then on, always have grit available.

On the seventh day, fowl pox vaccinations may be recommended. Decrease the temperature to 31.1°C (90°F) and remove the brooder guard.

On the fourteenth day, lower the temperature to 29.4°C (85°F).

On the twenty-first day, provide larger feeders and lower the temperature to 26.6°C (80°F).

On the twenty-eighth day, lower the temperature to 23.9°C (75°F). If recommended by local authorities, vaccinate against Newcastle disease and bronchitis.

On the thirty-fifth day, you may begin vaccinating for bronchitis and fowl cholera, if appropriate. Place waterers on a slatted or wire mesh platform and lower the temperature to 21.1°C (70°F). If nighttime temperatures do not fall below this level, remove the brooder. Even in cold weather, you may remove the brooder a week later. However, make sure that drinking water does not freeze.

Meat-Breed Management

Once meat birds have been vaccinated on the thirty-fifth day, they may not need any more special care, as they should be sold by 10 weeks of age. If they are kept beyond 10 weeks, they will probably need larger feeders.

Watch the flock and treat for outbreaks of worms, coccidiosis, parasites, and other health problems.

Remove any sick birds. If there are more than one or two, perform a postmortem examination or take the birds to a veterinarian or a laboratory for analysis.

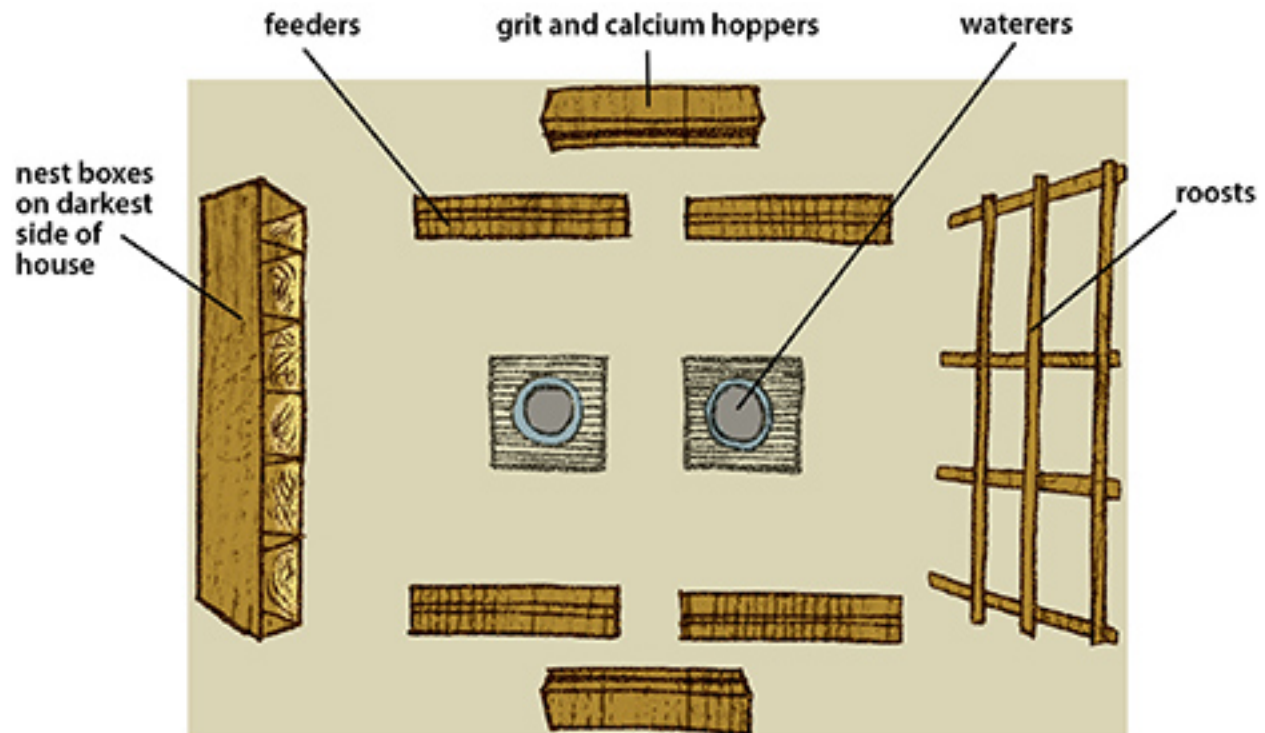
Layer Management

Layers should be kept in the same house or cage during their laying year. Moving them when they are laying may cause them to stop laying for several weeks. They need water and feed available continuously during daylight, and their calcium requirements are high.

On the forty-second day, vaccinate for fowl pox, if recommended by local authorities. On the fifty-second day, vaccinate for Newcastle disease. On the eighty-fourth day, increase feed and water space. Begin a lighting program, if appropriate.

Ch 5: Poultry Husbandry

Figure 5-15: Layout of Layer House



During the fifteenth week, if you plan to use roosts, put them in the house.

During the sixteenth week, if dead or culled birds show signs of worms, begin medication.

During the nineteenth week, place nesting boxes in the house so the pullets get used to them before laying.

During the twentieth week, change to a laying ration. Cull all pullets that look sick. If you are going to use cages, place hens in them this week. You do not have to change to the laying ration until 50 percent of the flock is laying. The main difference between a laying ration (fed to layers) and a grower's ration (fed to growing birds) is the amount of calcium in it. Chickens should not be fed extra calcium until 50 percent of the flock starts to lay.

White-egg breeds should begin laying at 21 weeks. The chickens might start laying at 16 to 22 weeks if the lighting program is wrong. Brown-egg birds should begin laying at 23 or 24 weeks.

Look for any eggs outside the nests. Hens found laying in other places should be introduced gently to a nest with an egg in it. Once hens begin laying, they should not be disturbed in any way.

Egg production should peak at about 85 to 95 eggs per day per 100 hens, and then fall gradually to about 55 to 70 eggs at the end of 12 months of laying.

Genetically improved layers today appear to molt (lose and replace feathers) throughout their adult lives rather than to lay eggs for a period, molt, and start laying again. There are several factors that can influence how long a flock of layers will produce economically. These include breeder, egg, feed prices, and environmental factors, including general management, weather, and seasonal considerations. Normally, layers are kept for 12 months of laying. If flock replacement costs are high, then it may be economical to keep them for another six months. Under good management conditions, Leghorns may continue laying at an economical level for up to 18 months, and some heavier breeds may continue laying for up to 15 months.

The time to replace a flock is determined by many factors, and it is wise to consult with local poultry authorities before making decisions. Checking feed and market-price history, seasonal considerations, and historical data on breed sources, if available, will help in decision-making. Of course, this must be done in sufficient time to allow preparations for the five- to six-month rearing period.

Lighting

Light is a stimulus that has a direct impact on egg production. Increasing daylight has a positive influence on egg laying. Decreasing daylight has a negative influence. Thus, under natural lighting, a country hen not near the equator begins laying eggs as the days grow longer in spring and tapers off as the days become shorter in the fall. The new breeds respond the same way when kept in natural light. This means that all hens on a natural schedule in a given area will hit peak production at the same time of the year, causing overproduction and low prices in some seasons and scarcity and high prices in others.

If you want your hens to produce best during periods of high prices, pay attention to the length of their day. Layers need 14 to 16 hours of light during a day for optimum production. If they receive less light, or if the length of the day is decreasing, egg production will suffer. However, if pullets under 21 weeks are exposed to lengthened days, they may start laying before they are physically ready to maintain production. This can harm them. If egg prices are even throughout the year, you can take advantage of natural lighting and hatch or buy chicks 21 or 22 weeks before the shortest day of the year (December 21 in the northern hemisphere, June 21 in the southern hemisphere). That means starting the flock between July 18 and 25 in the northern hemisphere and between January 19 and 26 in the southern hemisphere.

If this timing does not match local market conditions or chick availability, or if local weather conditions are prohibitive (such as monsoon rains accompanied by heavy winds), you can

Ch 5: Poultry Husbandry

consider manipulating the length of the “day.” Chicks and pullets should have decreasing daylight until they are 21 weeks old. When the brooder is turned off, use kerosene lanterns or electric light bulbs before sunrise or after sunset to artificially lengthen the natural day so that peak production will result at the desired time. The correct intensity or amount of light is necessary for proper lighting. You will need the equivalent of one bulb watt for every 4 square feet. Thus, a 40-watt bulb is sufficient for 160 square feet. For large areas, use more bulbs to ensure even distribution of light, especially on feeders and waterers. Lamps and light bulbs get very dirty in a chicken house, so clean them once a week.

If you know how long the natural day will be when the pullets are 21 weeks old and you decide that the use of artificial lights will be necessary, determine your artificial lighting needs. The following example will help you in this decision:

Assumptions:

- Egg prices are projected to be highest during October, November, and December.
- You are in the southern hemisphere.
- The longest day is December 21. The shortest day is June 21.

Your breed of chickens will begin laying during the 22nd week of age and will produce at peak levels for about three months. Their peak three months will be from week 27 through week 40. This will occur during the months desired if you use the following lighting program.

First, count back to the time you need day-old chicks. Assume your chick supplier can provide them on March 20. Working back from the day length at 21 weeks:

Age (in Weeks)	Dates	Day Length (Hours)
1–5	March 20–April 30	Brooder Lights
6	May 1–7	16
7	May 8–14	15 3/4
8	May 15–21	15 1/2
9	May 22–28	15 1/4
10	May 29–June 4	15
11	June 5–11	14 3/4
12	June 12–18	14 1/2
13	June 19–25	14 1/4
14	June 26–July 2	14
15	July 3–9	13 3/4
16	July 10–16	13 1/2
17	July 17–23	13 1/4

Ch 5: Poultry Husbandry

Age (in Weeks)	Dates	Day Length (Hours)
18	July 24–30	13
19	July 31–August 6	12 3/4
20	August 7–13	12 1/2
21	August 14–20	12 1/4

Now, you want to bring them into production. The natural day length on August 21 is 12 1/4 hours, and you know the natural day length will increase until December 21. After December 21, the longest day of the year in the southern hemisphere (south of the Equator), natural daylight will decrease. Since you don't want the chickens' egg production to slow due to the decreasing day length, you must begin to use artificial lighting. Thus:

- August 21 through December 21, the natural day length increases. No artificial lighting is needed.
- Assume the natural day length on December 21 is 14 hours.
- Beginning on February 15, keep a steady 16 hours through the end of the 12-month laying cycle, sometime after August 21.

Dates	Day Length (Hours)
December 21	Natural: 14
December 22–28	14 1/4
December 29–January 4	14 1/2
January 5–11	14 3/4
January 12–18	15
January 19–25	15 1/4
January 26–February 1	15 1/2
February 2–8	15 3/4
February 9–15	16

This schedule has accomplished the following objectives:

- The day length was artificially decreased up to week 21 using a “step-down” lighting program. The step-down program prevents the chickens from starting to lay eggs too early.
- The day length was increasing after the week 21, when you wanted to stimulate egg production. If this had come at another time of year, you might have had to use artificial lights beginning at the week 21.
- The day length was artificially increased beginning on December 22. If this had not been done, egg production would have slowed substantially. This series of light increases is called a “step-up” program.

Ch 5: Poultry Husbandry

For a step-up program, it is important not to increase day length too rapidly, because this can damage to the reproductive system. An increase in increments of 15 to 20 minutes per week is the maximum recommended.

Forced Molting

After one year of egg production, a hen typically stops laying. She then molts, shedding and replacing her feathers. About seven weeks later, she resumes laying, but at a lower rate than the year before. The eggs will be larger than with new pullets, but will have thinner shells, resulting in more breakage. Although you feed new chickens for 22 weeks before they begin to lay and molted birds only seven weeks, molted birds eat more per day. Most farmers sell the older flock at 18 months of age and have a new one ready to start laying.

There are times when it can pay to keep the old flock, such as if replacement birds are not available, or if egg prices will be very high in a period 2 to 10 months in the future. In such cases, a forced molt reduces the time needed and puts all birds on the same schedule. However, it is usually uneconomical to force brown-egg breeds to molt, due to their higher feed requirements.

Generally, forced molting is not a procedure used for the most genetically advanced layers. However, it is used in some situations. A typical case for forced molting is one in which there has been a severe nutritional or environmental stress that has resulted in a drop in egg production between the sixth and eighth months of production. The situation by that time is a flock laying at perhaps a 50 percent level, and not likely to recover to full production unless forced to molt. Forced molting is like rebuilding a car engine to make it more efficient.

To force a molt, begin when the hens are producing at a rate of fewer than 45 or 50 eggs per 100 birds per day. If you are using artificial lights, stop. Do not feed the flock the first two days. Then, for the next two days, give them just enough feed so they finish it two hours before sunset. Do not provide water the first day, provide half the normal amount on the second day, and give them a continuous supply thereafter. On the fifth day, resume the lighting program, if you use one. It will take about six to eight weeks to bring them back to full production. The flock should produce well for another six to eight months.

Culling

Removing sick or poorly producing chickens from a flock is called culling. When you cull birds, you lessen the chance of spreading disease, and you reduce the waste of feeding non-layers.

During a flock's first five months, watch for sick birds. In village flocks of fewer than 50 chickens, you can put sick birds in a special pen. If they recover, they can rejoin the flock, but

be careful—an apparently recovered chicken may still carry disease back to the flock. In larger flocks, it is often better to destroy obviously sick chickens. Examine them closely or take them to a veterinarian.

Culling may increase the profit from a laying flock by up to 10 percent. This takes experience, since some layers go through pauses in production, and culling them loses future eggs.

As you gather eggs, gently examine hens that have just laid. Their combs will be large, bright red, and waxy, their earlobes and wattles smooth and soft. The area between their pubic bones and breastbones will be large, soft, and pliable, and their vents will be large, oval, and moist. If they have been laying for several weeks, they will look bleached, as the yellow pigment in their bodies is going into their eggs. You can place three fingers between a good layer's pubic bones, and four fingers between her breastbone and pubic bones. Her feathers may be a bit worn and dirty from frequent visits to the nest.

About four weeks after laying begins, you can cull the obvious non-layers. A hen that is not laying will have a shriveled, pale, and scaly comb, her wattles and earlobes will be rough and dry, her vent will be small, puckered, yellow and dry, and her abdomen will be hard and fatty.

Ch 5: Poultry Husbandry

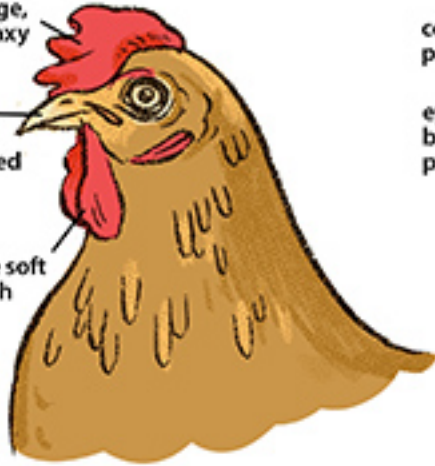
Figure 5-16: How to Tell a Good Layer From a Non-Layer

Good Layer

comb is large, red, and waxy

eye ring and beak are bleached

wattles are soft and smooth

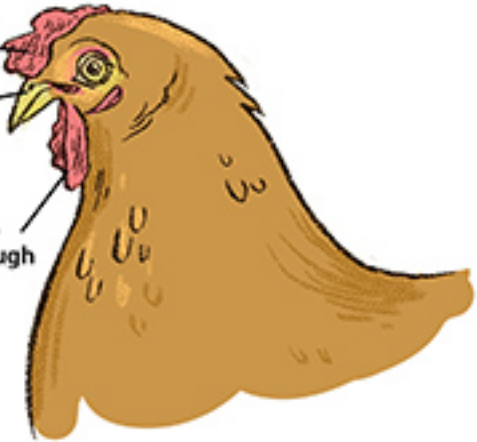


Non-Layer

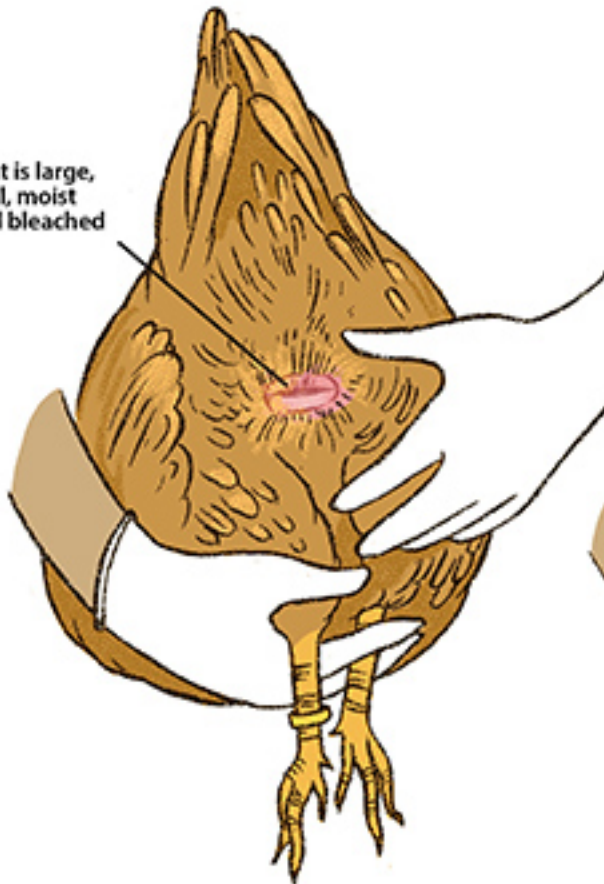
comb is shriveled, pale and scaly

eye ring and beak have yellow pigment

wattles are dry and rough



vent is large, oval, moist and bleached

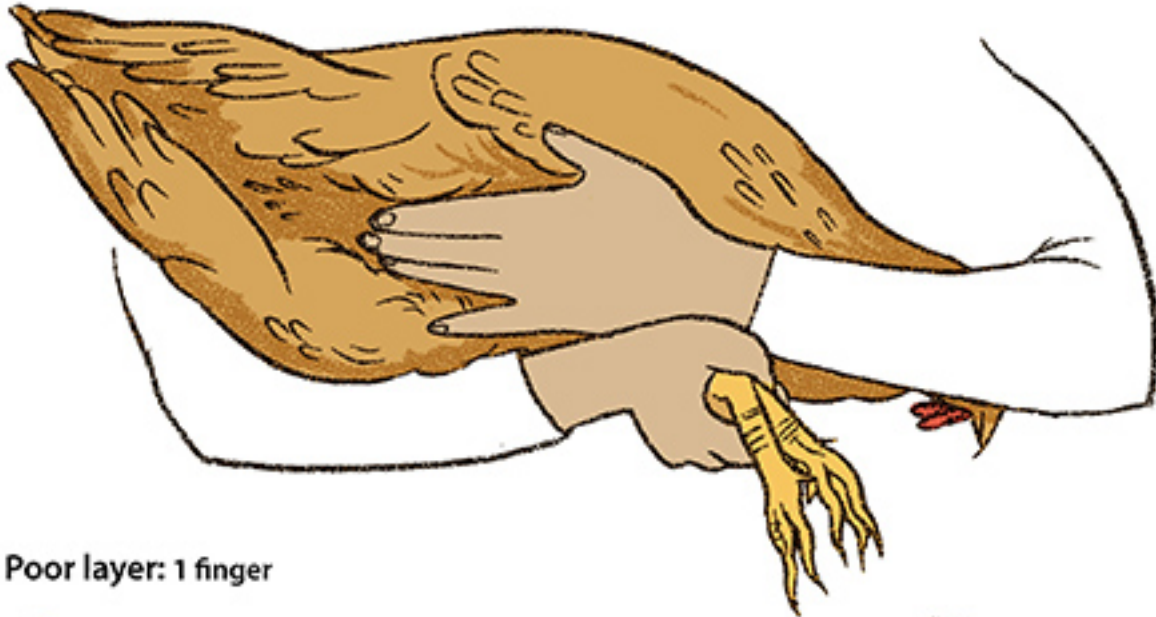


vent is small, puckered, dry and yellow

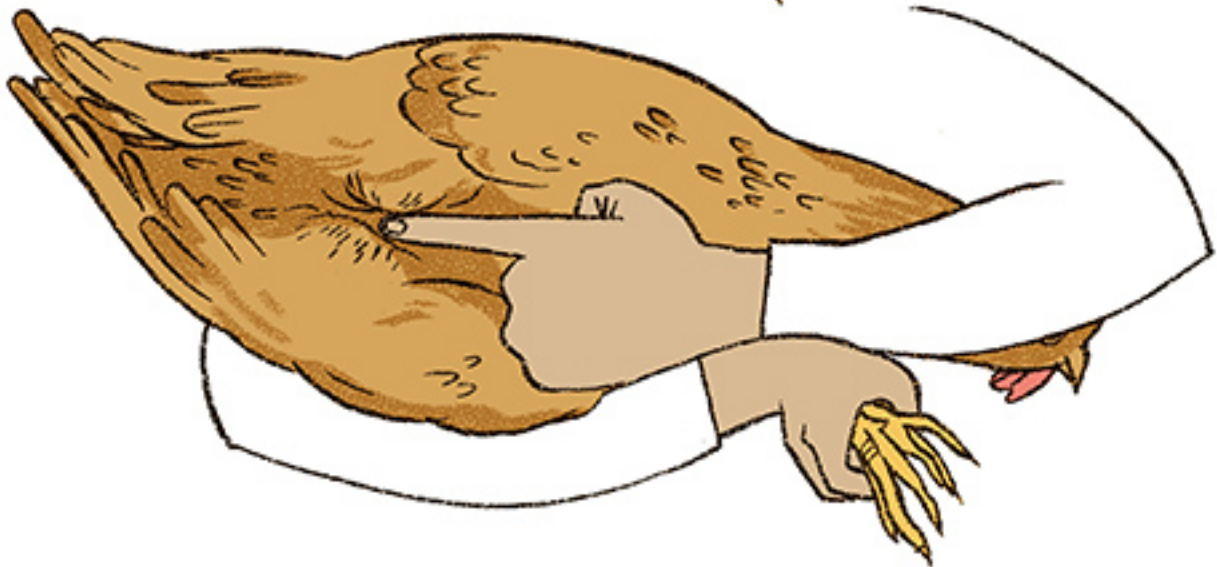


Figure 5-17: Examining Distance Between Pubic Bones

Good layer: 3 fingers

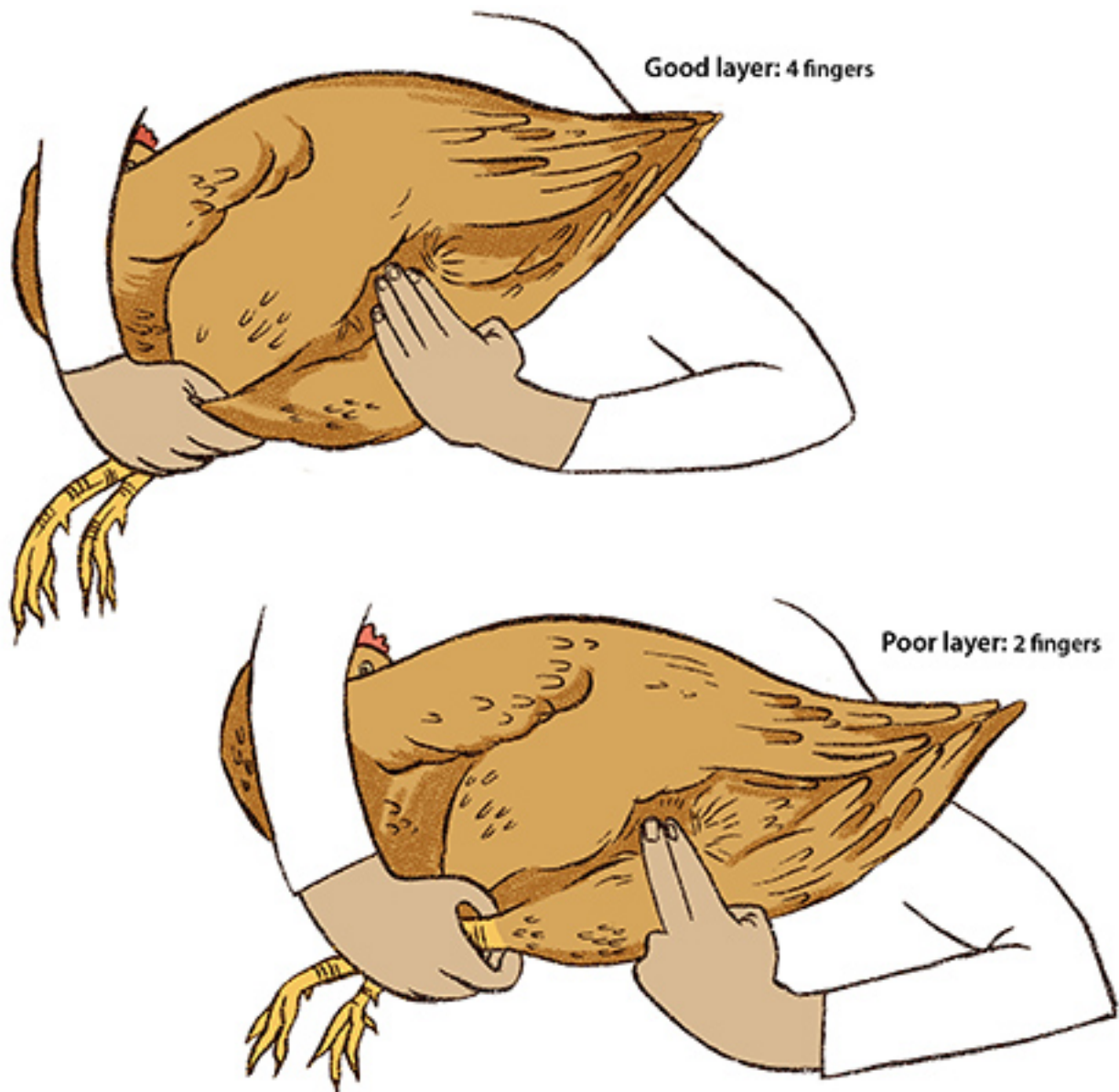


Poor layer: 1 finger



Ch 5: Poultry Husbandry

Figure 5-18: Examining Distance between Pubic Bones and Breastbone (Keel Bone)



Other General Management Principles

Stress Factors

Chickens subjected to stress will not produce at maximum potential. Examples of stress are:

- **Noises:** Barking dogs and nearby automobiles frighten chickens.
- **Rats and predators:** These disturb the flock and eat chickens and feed.
- **Strange people in the house:** If possible, the same person should attend the flock every day throughout the chickens' lives. Other than a veterinarian or an extension agent, no visitors should enter the poultry house. They can view the flock through the windows. This practice not only limits stress, it also reduces the chance of introducing disease. However, many farmers have children assist in tending the flock. This is acceptable as long as it is also done on a regular basis.
- **Changes in routine:** The farmer should visit the flock at the same time each day.
- **Vaccinations:** The stress of vaccinations cannot be avoided, but it can be reduced by following the right schedule and handling the birds gently.
- **Moving the flock:** If possible, keep the birds in the same house throughout their lives.
- **Damp litter:** The smell of ammonia given off by damp litter is a source of stress. Damp litter is also an ideal medium for the growth of disease-causing organisms.
- **New chickens in the flock:** During the early weeks of their lives, chickens in a flock establish a hierarchy of dominance, known as the "pecking order." When new chickens are introduced to the flock, the order has to be re-established over several weeks, while growth and production suffer. New birds in the flock also can introduce disease.
- **Violent weather:** Reduce the effects of storms by partly covering windows with shutters, burlap, or mats. Allow some air circulation for ventilation and remove the window covers as soon as the weather clears.
- **Very hot weather:** When the temperature in the chicken house exceeds 32.2°C (90°F), it is an extreme stress. Above 37.8°C (100°F), some chickens may die.
- **Cannibalism:** Chickens may attack and even kill other chickens.
- **Decreased day length:** Layers need at least 14 hours of light for maximum egg production.

In short, a stressful situation occurs with each deviation from good management practices and whenever chickens are subjected to something other than the daily routine.

Ch 5: Poultry Husbandry

Males and Females

Young male and female chickens can be kept together until the cockerels become sexually mature. At maturity, cockerels should be isolated from the females because they will begin to bother the females, as well as each other, creating stress. Cockerels are sexually mature when their combs and spurs show rapid development—between 12 and 18 weeks of age.

Mortality

Expect to lose about 1 percent of the flock each month. Some will die suddenly; others will show obvious signs of disease. Remove them and perform a postmortem examination. If the mortality rate exceeds 1 percent per month, seek veterinary advice immediately. This may be an early warning of a severe outbreak.

It is best not to eat obviously diseased birds or those that die of unknown causes. Bury the bodies in the ground. If wild animals or dogs dig up buried chickens, you will have to burn the bodies or construct a deep pit in the ground with a solid cover.

For small flocks of 50 to 100 chickens or fewer, you may want to use an isolation pen for the period of sickness. This is not a good practice in larger operations.

Hot Weather

Chickens do not perspire for relief from heat; instead, they pant and hold their wings away from their bodies. When the temperature exceeds 37.8°C (100°F), chickens may die from heatstroke. Make sure they have plenty of shade and cool drinking water, and completely open all ventilation areas. Add extra waterers or buckets of water to reduce crowding. Chickens in cages should be sprinkled with water, especially if any deaths occur. Chickens on deep litter—and the deep litter itself—can be sprinkled at mid-afternoon to increase evaporation.

Cannibalism

An accidentally injured bird with blood on it will be pecked, sometimes to death, by other birds.

Pecking may also start when chickens are overcrowded, fed an inadequate diet (especially a salt- or protein-deficient diet), are growing permanent feathers, or when there is a lice or mite infestation. To prevent cannibalism, good management is of prime importance.

Once a pecking problem occurs, some measures may help, including:

- Reduction of flock density by expanding the available space or removing some birds.
- Placing evergreen boughs (such as pine) with needles, leaves, fresh-cut green grass, or torn-up newspapers in the pen when pecking begins to be a problem. The chickens will be diverted to pecking at these rather than each other.
- Improving the diet.
- Treating for lice or mites.
- Spreading pine tar or other non-toxic, bad-tasting substances or commercial preparations over the wounds of pecked birds.
- Always removing pecked birds from the flock.
- Temporarily removing the most aggressive birds from the flock.

Debeaking

Depeaking is another option to address pecking problems. It should be stressed that debeaking should be performed only as a last resort after all other options have been tried.

To prevent chickens from pecking each other and to reduce feed wastage, many farmers make it a standard practice to cut off a portion of the upper beak and the tip of the lower beak. Other farmers debeak only if the flock starts pecking.

Although debeaking results in lowered aggression, feather pecking, and cannibalism, several anatomical, physiological, and biochemical changes occur following beak trimming due to cut peripheral nerves and damaged tissues. There is a considerable body of research demonstrating several markers of acute and chronic pain due to trimming. Importantly, debeaked chickens cannot pick food up from the ground.

An approach for controlling feather pecking and cannibalism in chickens should combine breed selection, housing design, and management practices that provide a more promising option and prevent the need for beak trimming.

Indigenous Practice and Poultry-Raising

In addition to improving commercial poultry production through the introduction of “modern” technologies, there will be opportunities to support and improve household poultry production. Many people will not have access to extension services, medications, and perhaps only limited resources to invest in improvements. However, Volunteers should understand that there are often veterinary practices, varied according to location, that can aid in chicken

Ch 5: Poultry Husbandry

production, help manage disease, and increase the output of low-input, smallholder systems. For example, in Botswana, medicinal herbs are used successfully to treat diseased poultry.

Volunteers can aid in the documentation and dissemination of these practices. In addition, several publications detail organic production practices, some of which may be appropriate and transferable to different geographic regions. (See Glos, Karma. *Humane and Healthy Poultry Production: A Manual for Organic Growers*. Chelsea Green Publishing, 2011.)

Rat Control

Rats and mice are the financial enemies of people raising poultry. In one day, a single rat eats as much feed as an adult chicken. Rats also spread disease, eat young chicks, and disturb the flock. Snap traps and locally recommended poisons can be quite effective, but be sure that chickens, other animals, and children are unable to access them.

Poison bait should be placed in a small tunnel or box with an entrance at one end and an exit at the other, located in poultry house corners or near entrances to rat tunnels around the perimeter of the chicken house or feed storage areas.

Local climate, building methods, management systems, space availability, and size of the flock all will influence the construction of a chicken house and other equipment. Of these considerations, the management system is probably the most basic.

Free-Range Systems

Whether overnight shelter is provided, any kind of free-range system is usually unacceptable for new breeds. Losses to disease and predators will be much too high to justify costs.

Contained, Limited-Range Systems

The many variations of this type of system all seek to protect the chickens from disease and predators, while allowing them to find some food for themselves in a fenced area or range.

Advantages

- The cost of feeding the chickens can be reduced by as much as 20 percent if the range is well-managed with a good growth of grass.
- Using grassy areas under fruit or other crop trees as range can mean more efficient use of that land.
- Sunshine provides vitamin D; chickens kept out of the sun need supplemental vitamin D in their feed. (Depending on their diets, chickens will need other vitamin supplements as well.)
- Exercise and outdoor life produce tougher but tastier chickens that some people prefer.
- Inside a fence, the chickens receive some protection from predators.
- Isolating the flock from other chickens provides some degree of protection from disease.
- What the chickens eat outside the house can be estimated and allowed for when mixing feeds.
- When the range is large, stress due to crowding is reduced.

Disadvantages

- In areas with prolonged rains, the chickens stay inside the house night and day. Therefore, houses have to be as large and well-equipped as those without ranges. Thus, in addition to equal housing costs, farmers must pay for fencing.
- If grass on the range is sparse, savings on feed costs will be slight. Land that grows lush grass often is more profitably used for cereal grains or other food crops.
- Unless the fence is at least 2 meters (6 feet) tall, the farmer will have to clip the flight feathers on one wing of each bird. Small, light breeds can fly over even taller fences.

Ch 6: Housing and Equipment

- Other species of birds entering the range will carry pests and diseases, especially fowl cholera.
- The chickens should be rotated to a fresh range every few months to prevent the buildup of disease-causing contaminants in the soil; this requires more land.
- Maintaining a range and a house requires more labor than maintaining just the house.

Recommendation

Unless unusual local circumstances favor this system, farmers will do better using a fully contained system.

Contained Systems

Contained systems allow the farmer more control over diseases and feed, and provide protection for the birds against predators. Contained systems vary, from makeshift cages in the corner of a veranda or porch to fully automated batteries of thousands of birds. This manual concentrates on those of smaller scope, but the principles are the same, no matter how large the project. There are four kinds of contained system.

Chicken Tractors

Chicken tractors are moveable coops that lack a floor and can be moved around so chickens are protected, yet are able to forage and supplement their diets with weeds, bugs, and stray seeds. An additional benefit is that as they scratch and forage, they work their manure into the soil. Chicken tractors can be built from locally available materials and according to farmer needs.

Deep Litter

Properly managed deep-litter systems provide excellent environments for the improved breeds and yield valuable fertilizer as well.

Advantages

- Deep litter is a good insulation. It protects chickens from cold weather, and during hot seasons they can nestle into it and reach the cool floor below.
- Studies show that when all other factors are equal, layers produce more eggs on deep litter than in cage systems.
- Chickens can be brooded and kept in the same house throughout their productive lives.

Ch 6: Housing and Equipment

- Deep litter allows the bird to dust itself against lice and other parasites.
- When a production cycle of 100 layers is finished, the litter and manure combination will be enough to fertilize a 0.4 hectare (1 acre) area of rice, wheat, or other cereal grain, or a 0.2 hectare (0.5 acre) area of intensively cultivated vegetables. (Note: Do not apply manure directly to growing crops, because its high nitrogen content will harm them.)
- Deep litter is an improved system that is readily adaptable to the traditional night shelters used in many village situations.
- The chicken, by nature, scratches and pecks in the litter, re-ingesting wasted and undigested food. In this process, some feed is recovered. During this time, the chicken picks up enzymes that are believed to reduce the chance of “gizzard erosion,” a problem that rarely occurs when chickens are kept in a deep-litter system. Fatty liver syndrome is also less likely in floor birds.

Disadvantages

- There is a greater chance of worm and tick infestation and coccidiosis (internal protozoan parasites) than with cages or raised-floor systems.
- The deep-litter system is inappropriate for very humid areas (80 to 90 percent humidity), because damp litter spreads diseases.
- The litter must be turned often, particularly in damp weather, and this requires more labor than other contained systems.
- Adequate litter is sometimes difficult to obtain.

Recommendation

Deep litter is recommended for meat birds and layers.

Raised Floor

In this system, floors are raised to about 1 meter (3 feet) above the ground and are made of wooden slats, wire mesh, or expanded metal. The chicken droppings should be collected frequently from under the house and composted.

Advantages

- In very humid climates, this is a healthier system for chickens than deep litter, because disease transmission through fecal matter is minimal.
- This system often is better suited for a few birds, unlike deep litter.
- In some areas, it costs less to build a raised-floor house than a deep-litter house.

Ch 6: Housing and Equipment

Disadvantages

- Young chicks cannot be brooded well in these houses. Since the floor is not insulated, it is difficult to maintain the high temperatures the chicks need, and walking on such floors is very difficult for chicks. Thus, a separate brooder house is needed.
- Raised-floor systems are unsuitable for hot, dry climates because the floors heat up unless they are built near shade trees. They also are unsuitable for use in cold seasons due to their lack of insulation.
- Unless the droppings are well-managed, they can attract flies and cause objectionable smells. Their value as fertilizer is also reduced.
- Egg production will probably be lower than with deep litter.

Recommendation

Use raised-floor systems in humid areas, where litter material is not available, and where construction costs are lower than for deep litter. This system is also recommended for meat breeds and layers.

Cages

Cages allow maximum control. They can be used for any number of birds, and construction costs can be geared to the desired size of the flock.

Advantages

- Cages can be placed under existing roofs; thus, a special building may not be required.
- With cages, more birds can be kept in a building than on deep litter.
- Less labor per bird is needed than with other systems.
- Poor layers can be identified immediately and culled, thus saving feed.
- Problems with parasites, particularly ticks, are reduced.
- When properly constructed, cages can last many years.
- Fewer disease problems are caused by transmission through fecal matter.
- Cages are a cheaper investment in the long run due to ease in care and feeding of the birds.

Disadvantages

- Cages are hard to construct properly.
- They involve very high initial investment per bird.
- There must be constant and excellent ventilation.

- There are more broken eggs than with deep litter.
- Nutrition may be a problem: the feed must contain all of the vitamins and minerals the birds need.

Recommendation

Cages are good for climates with high humidity, where labor costs are high, and when a farmer wants to keep a large flock of layers. Where ticks are a problem, cages are especially advantageous. Cages are recommended for layers, but are not generally used for meat birds.

Building a Chicken House

A good chicken house, no matter what its size or which materials are used, has certain essential features. These essentials, discussed further below, include a watertight roof, good ventilation with no cold drafts, internal surfaces that are easy to clean, adequate floor space for the number of birds contained, rat-proof floors and walls, and a well-chosen location.

Some sample chicken-house designs are given in Appendix A. If you will be building a chicken house, first build a model out of paper or cardboard. General considerations in building a chicken house are provided below.

Sites

Sometimes there is no choice of where to put a chicken house. If there is a choice, features of a good site are:

- Well-drained land not subject to flooding. This is especially important for deep-litter systems.
- Within sight of the farmer's home, but far enough away from other buildings to allow good ventilation.
- Near a source of clean water.
- In areas of high winds, the site should be protected by a hill, stand of trees, or other windbreak. Otherwise, a solid wall facing the prevailing monsoon or rain direction may be better.
- Well away from other chicken houses to reduce the spread of disease. An absolute minimum space between houses is 10 meters (32 feet), but the more, the better.
- In hot climates, placing the house under tall shade or crop trees, such as coconuts, will protect it from the sun. Bushy trees that block ventilation won't do.
- Away from roads, work areas, and other noisy places to reduce stress caused by disturbances.

Ch 6: Housing and Equipment

Floor-Space Requirements

A crowded chicken is an unhappy, unproductive chicken prone to peck other chickens, sometimes so severely that they die. Putting too many birds in a confined space is a false economy.

Below are recommendations on space requirements. Large layer breeds need somewhat more space than smaller breeds. More space is also needed in very hot and/or humid climates. Some farmers have experimented with crowding chickens purposely to reduce their per-bird investment in housing and equipment. They have reduced the space per bird to as little as 930 square centimeters (1 square foot), but usually have found that providing less than 22.5 square centimeters (2 1/2 square feet) per bird, even with sophisticated ventilating equipment, is unprofitable.

A common sign of overcrowding is when the birds begin pecking each other. The only practical remedies available to small-scale farmers are to provide more space, which may be difficult, reduce the size of the flock, or debeak the chickens.

Meat Breeds

Space requirements should be based on the maximum size the flock may attain with good care and good luck. If 110 chicks are purchased, 10 will probably die during the 8- to 12-week growing period. One hundred ready-for-market birds need 14 square meters (150 square feet). If they are kept beyond 12 weeks, they will need more space—at least 28 square meters (300 square feet) by 14 weeks—but they should be sold before this age.

Layers

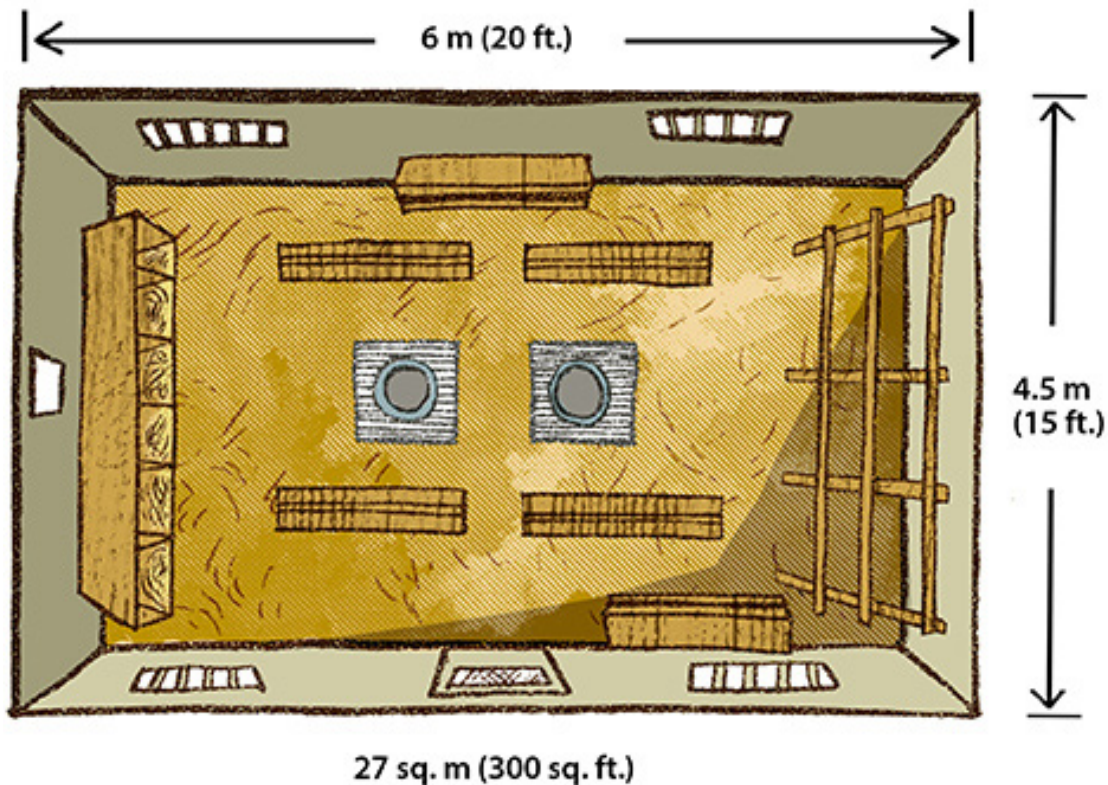
Because they will be kept longer than meat birds, start with 115 sexed chicks for every 100 layers desired. Average space requirements for small breeds of layers (White Leghorns, for example) are given in the table below. Under good management, 0.225 square meters (2.5 square feet) per lighter breed layer is sufficient; this is recommended for more experienced farmers using deep-litter systems. On slatted-floor systems, 0.18 square meters (2.0 square feet) for each adult bird is sufficient space. A space of 27 square meters (300 square feet) should be enough for 100 layers throughout their lifetimes, and enough for 200 broilers up to the age of 12 weeks.

Note: This is living space. It does not include space occupied by feeders, waterers, and other equipment.

Table 6-1: Space Recommendations

Age, in Weeks	Space per Bird		Space per 100 Birds	
0–6	650 cm ²	100 in ²	6.5 m ²	75 ft ²
7–12	930 cm ²	1 ft ²	9.3 m ²	100 ft ²
13–16	18.6 m	2 ft ²	18.0 m ²	200 ft ²
17 and up	27.9 m	3 ft ²	27.5 m ²	300 ft ²

Figure 6-1: Space Requirements for Chickens on Deep Litter



Dual-Purpose Breeds

Space requirements for dual-purpose breeds are the same as for meat birds until the males are sold. After that, use the recommendations for layers.

Ventilation

Chickens need more fresh air per unit of body weight than any other livestock. In addition to stale air, they exhale or excrete large amounts of moisture, up to 0.37 liters (3/4 pints) per bird each day. High humidity in a chicken house encourages the spread of disease, so good ventilation is important. Electrical fan systems are needed for wide or densely populated houses. Natural air circulation or gravity systems (natural circulation assisted by flues) should

Ch 6: Housing and Equipment

not be used for houses wider than 9 meters (30 feet). In hot, humid climates, many large windows or screened openings are needed. They should not be blocked by brush or nearby buildings.

Because this manual gives general instructions on poultry production, some recommendations and suggestions will not be relevant to every development worker's situation. Poultry workers will need to adapt methods and tools to their specific needs.

Tile

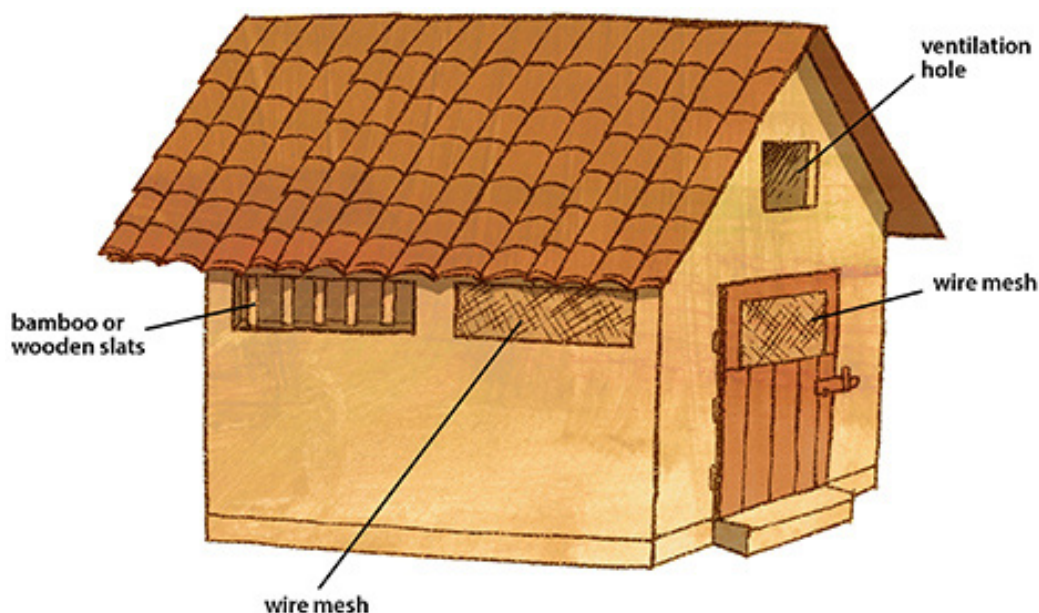
Although usually more expensive than thatch, sunbaked tile will last much longer. Because of the weight of the tile, the framing for a tile roof must be stronger than for other materials.

Windows

Window design depends on local climate. Chickens need more fresh air than humans, but they should also be sheltered from wind, dust, and rain. Protection from strong winds should be provided. During storms, windows on the wind-prone side of the house can be covered by permanent hinged shutters, burlap bags, straw or bamboo mats, and so on. In humid climates, window design should take as much advantage of the sun as possible to reduce the amount of moisture in the house, but the chickens should also have some shade at all times.

Window areas are best covered by wire mesh or expanded metal. Bamboo or wooden slats can be used, but this will reduce ventilation. In the end walls of gable buildings, a ventilation hole should be located near the roof peak.

Figure 6-2: Gable Chicken House



Door

Whether made of metal, wood, or bamboo, and whether solid or of wire mesh in the top half, the door should be sturdy enough to be opened and closed more than 1,000 times each year.

Deep-Litter Floors

The ideal floor for a deep-litter house is a concrete one designed for good drainage, embedded with heavy wire mesh to keep rats out. This is expensive. Strong bricks or large, flat stones can be used, but are harder to clean. Many small farms are limited to clay floors.

Deep-litter floors should be built in a well-drained area. If possible, put down a layer of heavy gravel or wire mesh first to keep rats out. Turn the edges of the mesh up about 25 centimeters (1 foot) to join the walls. The floor should be about 15 centimeters (6 inches) higher than the surrounding ground and slope slightly from the center to the sides for drainage. Pack it by tamping until it is firm and very smooth so that water cannot collect in holes. If possible, cover it with a 5 centimeter (2 inch) layer of cement. Otherwise, a fresh layer of clay should be applied between flocks. In order to reduce disease problems, the floor of a poultry house must be constructed such that thorough cleaning is possible between flocks or batches of chickens.

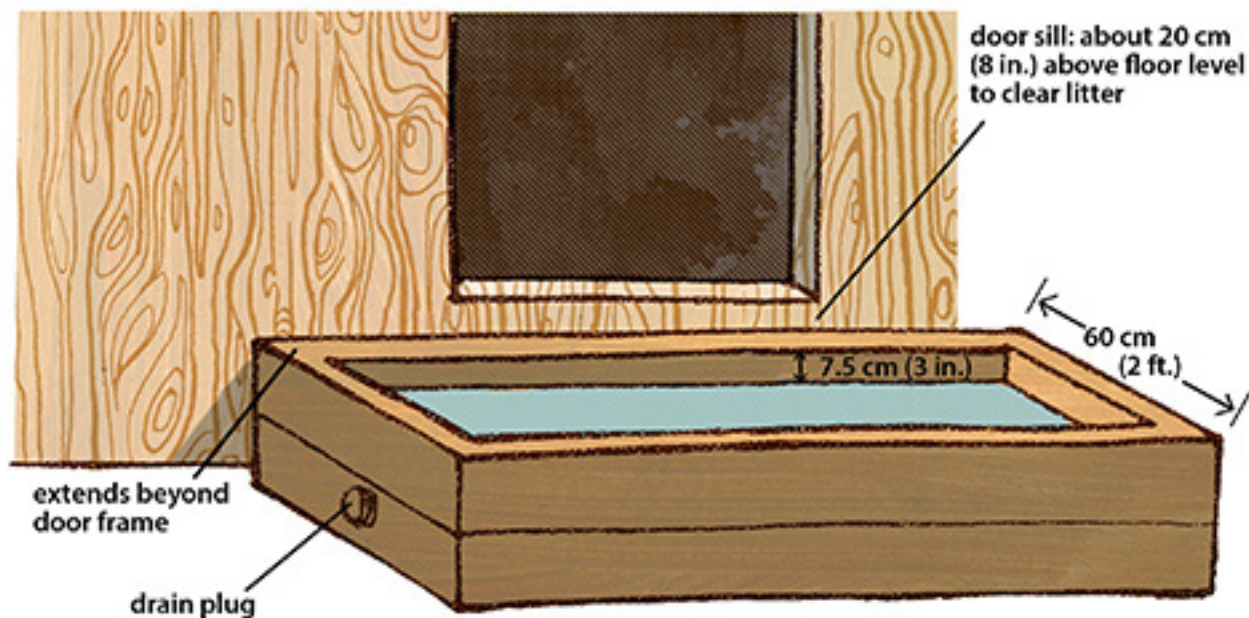
Disinfectant Dip

An optional but highly recommended part of a deep-litter house is a shallow, water-tight basin set flush with the doorsill and filled with disinfectant. A disinfectant dip has several advantages. First, it helps reduce the introduction of disease-carrying dirt. Second, and just as important, it is a daily reminder to the farmer of the importance of sanitation. It is especially important where barefoot farmers, or those who do not have spare pairs of shoes for each chicken house, visit more than one such house each day. The dip can be formed with mud or clay and lined with concrete or a sheet metal tray. In some cases, it may be better to construct a shallow, basin-like dip instead. The basin should be no more than 1.27 centimeters (1/2 inch) deep with a large center area. This has advantages over a deeper dip because the disinfectant solution and accumulated dirt can be swept out. People also are more likely to walk through a shallow dip than a deep one.

A cement-lined disinfectant basin should be large enough that it is difficult to avoid stepping into.

Ch 6: Housing and Equipment

Figure 6-3: Disinfectant Basin



Raised Floors

Local practicalities will influence selection of materials and design. Pillars that are not rot-resistant should have stone or concrete footings. Pillars may be made of wood, bamboo, oil drums, concrete blocks, or similar materials.

Floors should be about 1 meter (3 feet) above the ground: it is difficult to clean under lower floors, and higher ones make the building unsteady. Floor joists, depending on their strength, are spaced 1 to 2 meters (3 to 6 feet) apart. The floor can be made of:

- Wire mesh: The wire should be strong or “heavy gauge,” as large in diameter as a standard pencil lead, if possible. The maximum space between wire in at least one direction should be 2.5 centimeters (1 inches).
- Slats: Made of either wood or bamboo, slats should be 2.5 centimeters (1 inches) at the top and slightly tapered downward. They should be set 2.5 centimeters (1 inches) apart.
- Expanded metal: Although expensive, expanded metal is extremely durable. It should meet the same requirements as wire mesh.

Figure 6-4: Slatted Floors



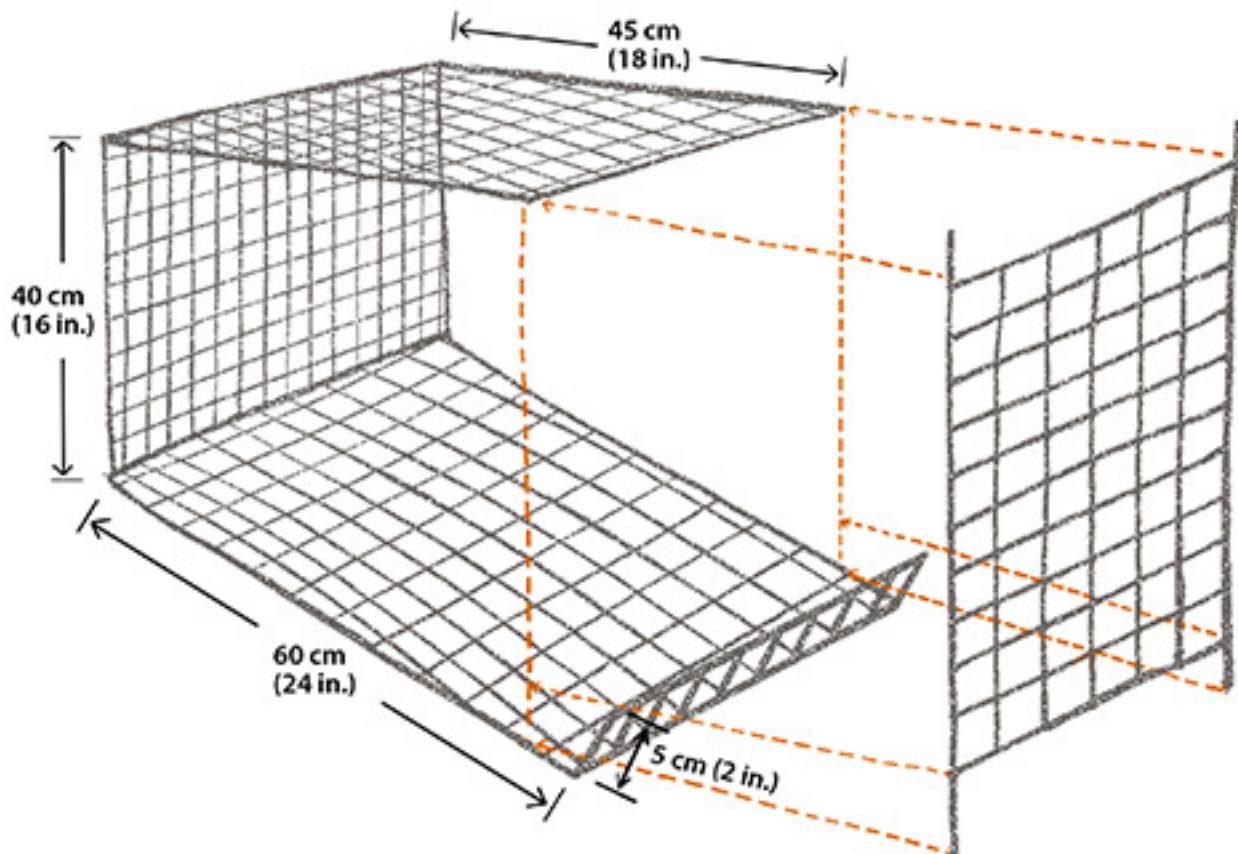
Making Wire Cages

In many poultry-producing areas, artisans specialize in making entire cages; some provide just the front, the most complicated part. Layers placed in cages should be debeaked severely. If you would like to make your own cages, you can use this relatively simple design. More elaborate designs use dropping boards or rolls of tarpaper to catch droppings.

Materials

- Wire mesh A: Wire with diameter of 2 millimeters (1/8 inch) welded into mesh spaced 2.5 by 5 centimeters (1 by 2 inches). This mesh is used for all parts of the cage except the front.
- Wire mesh B: Same diameter wire welded into mesh spaced 5 by 10 centimeters (2 by 4 inches). This is used for the front.
- Wire: Any heavy-gauge but pliable wire, to be used to join cage parts.

Figure 6-5: Wire-Mesh Cage Form



Ch 6: Housing and Equipment

Form

Cut a piece of wire mesh A 3.66 millimeters by 150 centimeters and bend it as shown.

Sides and dividers: Cut pieces of wire mesh A 40 by 45 centimeters (16 by 18 inches). Use four such pieces, spaced 122 centimeters (4 feet) apart for colony cages. Use 17 pieces spaced 22.8 centimeters (9 inches) apart for double cages. Secure the sides and dividers to the form with wire every 15 centimeters (6 inches) on the three sides that touch the form.

Front

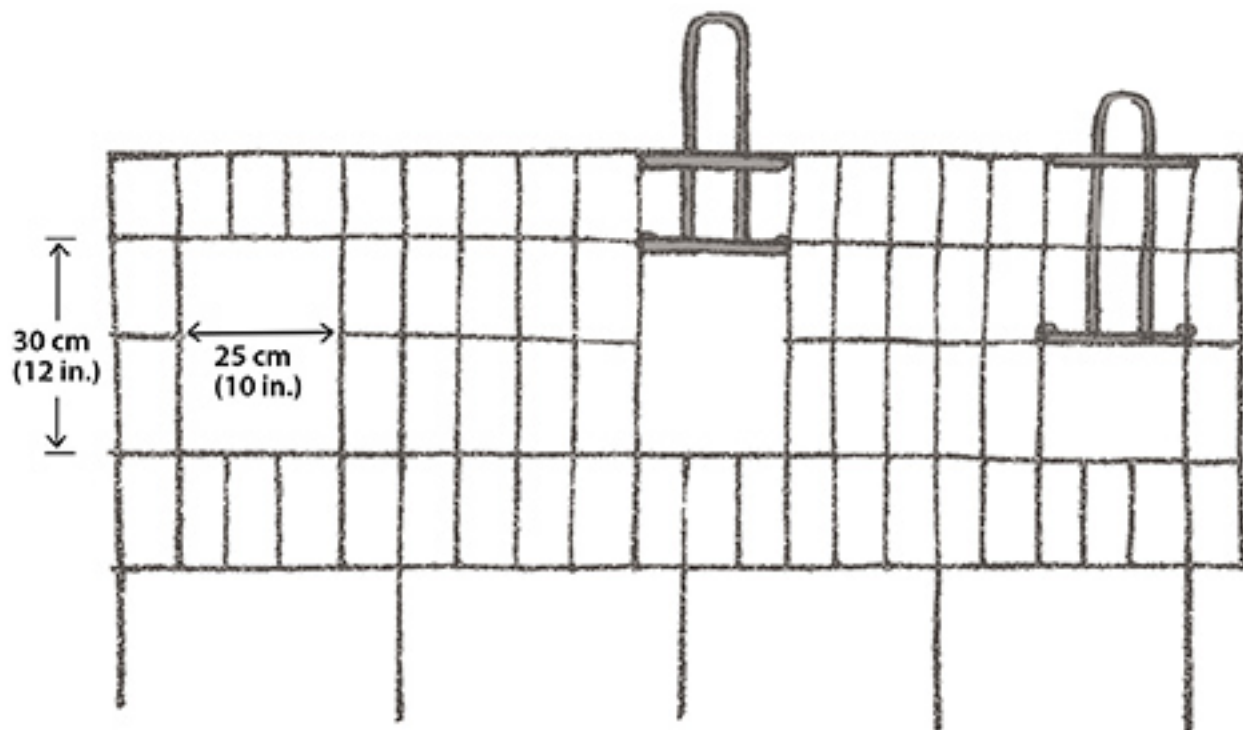
Cut a piece of wire mesh B 38 centimeters by 3.75 meters (15 inches by 12 1/4 feet). Use the protruding wires on the sides and top of the front to join it to the form. Secure the front to the cage dividers with wire.

Door Opening

At the center of each cage, cut a door opening 15 by 30 centimeters (6 by 12 inches).

Sliding door: Using wire mesh B, cut a piece (as shown by the darker lines). Bend the horizontal wires of the door opening, as shown below.

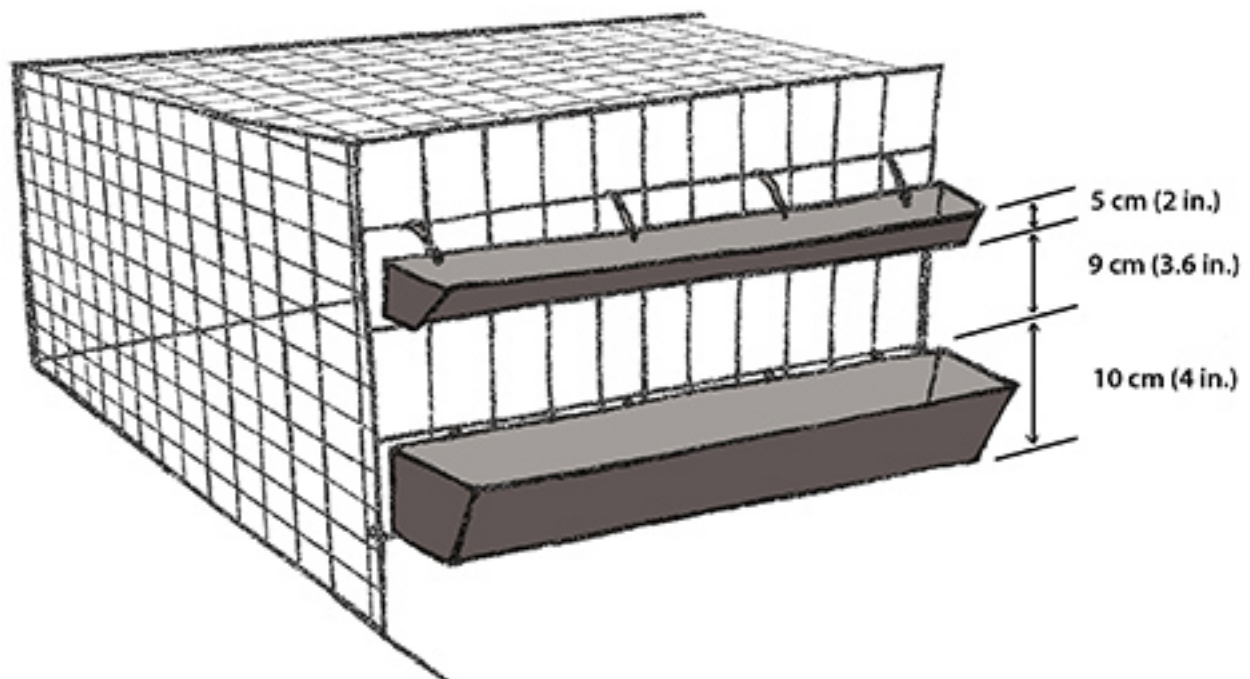
Figure 6-6: Sliding Door



Feeders and Waterers

Feed and water troughs made of sheet metal and mounted with wire hangers should run the length of the cage. If possible, the waterer should be secured on the opposite side of the cage from the feeder. Split bamboo can be used for feeders. Both feeders and waterers should be hung as high as possible on the cage to reduce feed wastage and splashing of water onto the feeder and poultry-house floor, but certainly not higher than the chicken can reach. A good rule of thumb is to place equipment no higher than the tail feathers of the chicken being put into the house or cage.

Figure 6-7: Feed and Water Troughs



Use of Cages

This cage is suitable for 18 layers, six to each colony cage or two to each double cage. Note: The cage must be hung so the back of the floor is 7.6 centimeters (3 inches) higher than the front. This allows the eggs to roll out. Excessive sloping of the cage floor will cause the eggs to break as they roll.

A single cage can be placed on a stand, or one or more cages can be hung from beams. The cages should be at least 62.5 centimeters (25 inches) above the ground or floor, and the area below them should be cleaned frequently. Hang cages on a slant so eggs will roll out.

Ch 6: Housing and Equipment

Figure 6-8: Cage on a Stand

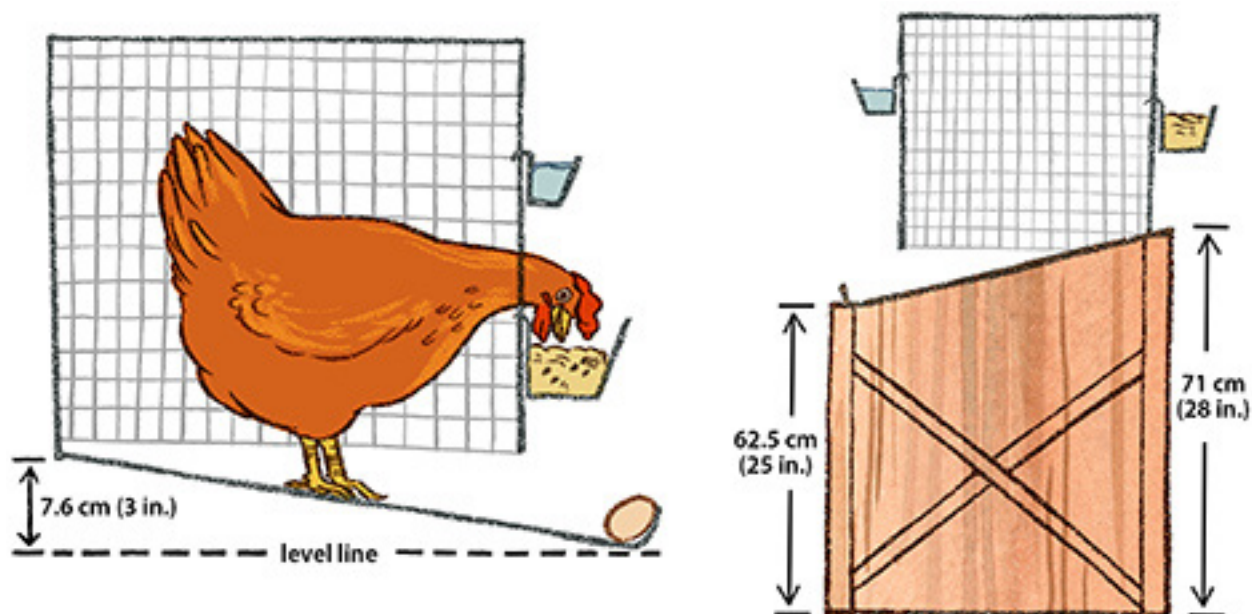


Figure 6-9: Cages Hung from Beams

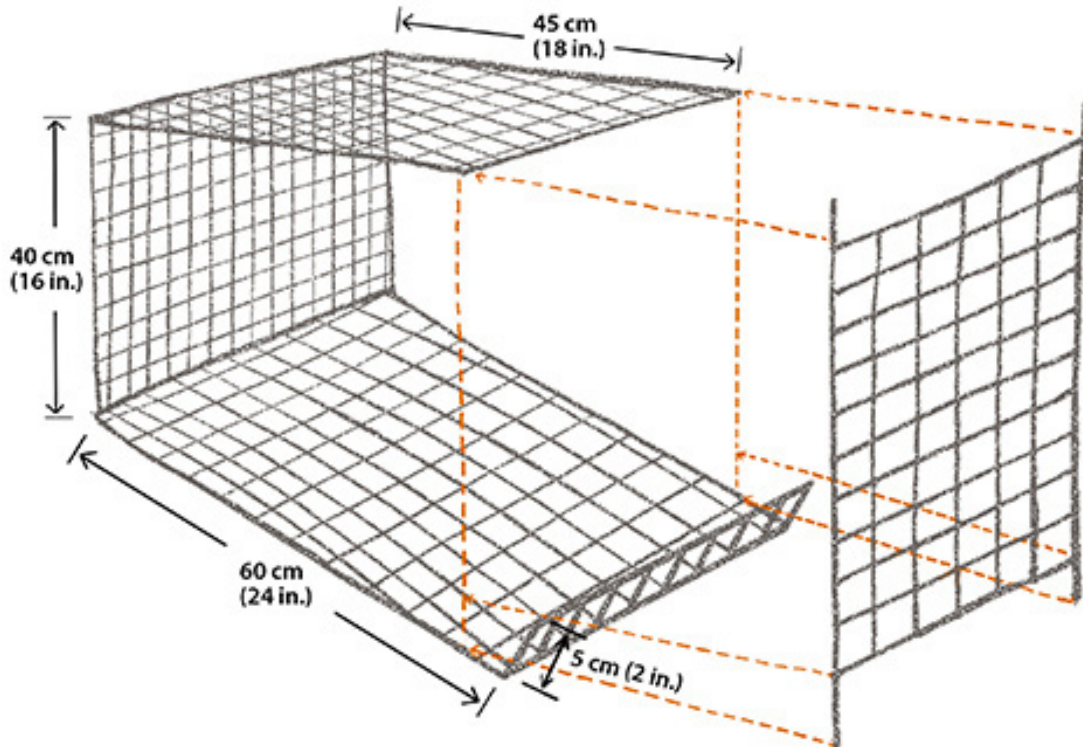


The above cage designs, which slant on all sides when hung, are recommended in areas where wire costs are high. This design has a certain disadvantage: feeders and waterers will have to be tightly secured to the cage to prevent them from hanging away from the cage.

Ch 6: Housing and Equipment

An alternative design uses a little more wire for the front of the cage.

Figure 6-10: Alternative Cage Design Using More Wire



Equipment

Equipment used in chicken houses can be made of local materials. This equipment receives heavy use and is cleaned often, so it should be sturdy. Local woodworkers and metalworkers can help with design and construction.

Waterers

Whether you use a straight trough or a round waterer, the length or circumference of the waterer's lip is important. Minimum lip length (space) is shown in the table below. Measure the lip available to the birds: when chickens use both sides of a trough, the lip available is twice the length of the trough. The capacity of the waterers must be sufficient to meet the chickens' daily requirements.

Ch 6: Housing and Equipment

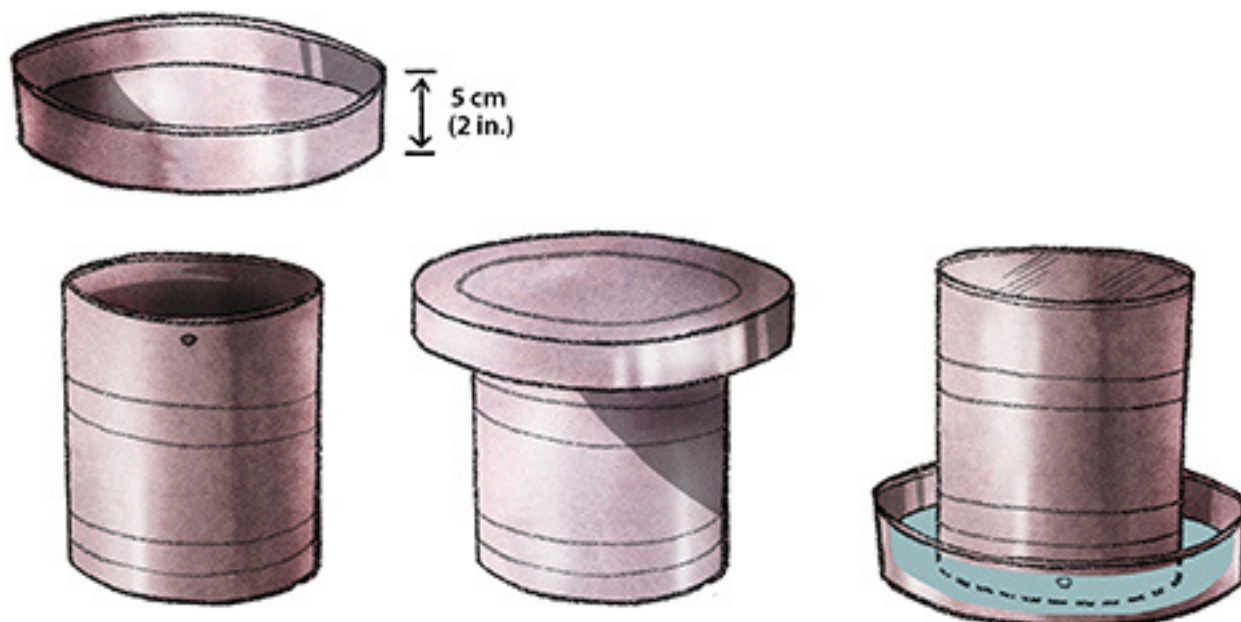
Table 6-2: Minimum Water Space Requirements for 100 Birds

Age, in Weeks	Daily Consumption	Space Required (Length)
0-1	2 liters (0.5-1 gallon)	0.7 meters (30 inches)
2-4	8 liters (2-4 gallons)	1 meter (40 inches)
4-9	15 liters (4-8 gallons)	1.5 meters (60 inches)
9 or more	19 liters (5 gallons)	2 meters (80 inches)
Layers	36 liters (9.5 gallons)	2.5 meters (100 inches)

Very Important Note: In hot, dry climates, chickens may consume up to four times the above volumes of water. Therefore, watch the water consumption carefully. You may need to increase capacity. Never allow chickens to run out of clean water.

The simplest waterer is a tin can inverted into a soup or pie plate or the bottom of a larger tin can. Punch a hole about 2 centimeters (3/4 inch) from the open end of the tin can. Fill the can with water and cover it with the plate. With one hand on the plate and one on the tin can, quickly invert both. The position of the punched hole and the vacuum in the tin can will regulate the water level in the plate.

Figure 6-11: Inverted Waterer



Ch 6: Housing and Equipment

Figure 6-12: Other Waterers (Left: nipple waterer; Right: bell waterer)

Photos c/o creativecommons.org



Automatic Waterer

Fit a large, clean oil drum with a faucet or other type of valve and a tight cover. Set the drum on a 1 meter (3 foot) stand of blocks, bricks, or reinforced clay mud, either inside or outside the chicken house. Run a hose or pipe from the faucet to one end of a galvanized sheet-metal trough about 10 centimeters (4 inches) high and 12.5 centimeters (5 inches) wide. The length of the trough depends on the size of the flock: a 1.2 meter (4 foot) trough will serve 100 birds if they drink from both sides. Level the trough (on flat rocks, wood blocks, etc.) so the lip of the trough is as high as the birds' backs. Fit an overflow hose or pipe 5 centimeters (2 inches) above the bottom of the trough in the side opposite the incoming water. Run the overflow pipe outside the house to a place where the overflow water will not run back into the house. Adjust the faucet or valve so the overflow of water is minimized. Protect the trough from contamination by birds using a spinner (a bar that rotates so chickens cannot roost on it) or constructing a cover over the trough.

Figure 6-13: Automatic Watering System

Photo c/o creativecommons.org



Ch 6: Housing and Equipment

Feeders

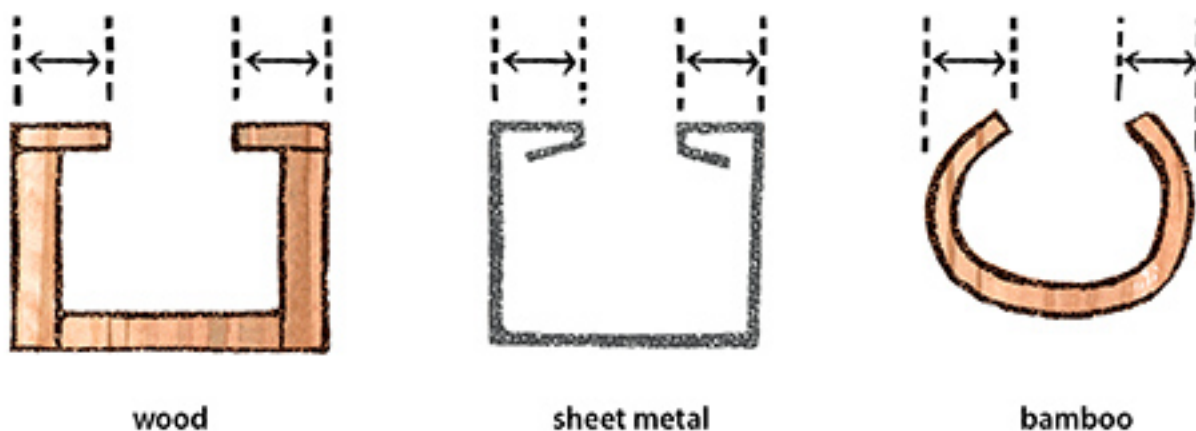
A well-made feeder is:

- Durable: It must withstand frequent cleaning.
- Stable: It should not tip over when bumped by the farmer or the chickens.
- The correct height and depth: As birds grow, increase the height and depth of the feeder.
- Chicken-proof: Birds cannot get into it or roost on it (use a spinner).
- Efficient: It should have a lip to prevent birds from “beaking” feed out onto the floor.

Distribute feeders evenly throughout the chicken house. No feeder should be more than 4.5 meters (15 feet) from a waterer. Adjust the height of the lip of the feeder to a level even with the backs of the birds. This will help prevent them from scratching contaminated litter into the feeders. In fact, the more they have to stretch their necks to reach feed, the less feed will be wasted.

Figure 6-14: Feeders with Lips to Prevent Waste

depending upon the size of the feeder, the lips should measure $\frac{1}{4}$ - $\frac{3}{4}$ in. ($\frac{1}{2}$ - $1\frac{1}{2}$ cm).



Except for the first three days with day-old chicks, feeders should not be filled more than half full, as feed will be wasted. One-third full wastes even less feed, but feed has to be supplied more often.

To reduce spoilage and mold problems, try to adjust amounts of feed supplied so the birds finish it by sundown. This will take practice. Supply the feed regularly at sunrise and about 2 p.m.—more frequently if the birds empty the feeder.

Ch 6: Housing and Equipment

When feeding chickens supplemental vegetable matter, don't throw it on the floor—suspend it at beak level with a rope, put it in a hanging net, or place it in a wire or slatted hopper (a feeder made out of wire mesh).

Feeder Space (Length)

As with waterers, feeder space is the linear distance of lip available to the birds—either the circumference of a round feeder tray or twice the length of a trough, if the birds feed from both sides. Minimum space and depth requirements are given below.

Table 6-3: Feed Requirements for 100 Chickens

Age in Weeks	Approximate Daily Consumption (Will Vary)		Space Required	
	Meat Birds	Layers	Feeder Depth	Feeder Length
1	1.8 kg (4 lbs)	1.4 kg (3 lbs)	5 cm (2 in)	2.5 m (100 in)
2	2.3 kg (5 lbs)	1.8 kg (4 lbs)	"	"
3	4.6 kg (10 lbs)	2.7 kg (6 lbs)	"	"
4	5.0 kg (11 lbs)	3.2 kg (7 lbs)	8.9 cm (3.5 in)	3.8 m (150 in)
5	6.8 kg (15 lbs)	4.1 kg (9 lbs)	"	"
6	7.3 kg (16 lbs)	5.0 kg (11 lbs)	"	6.1 m (240 in)
7	8.2 kg (18 lbs)	5.5 kg (12 lbs)	"	"
8	8.6 kg (19 lbs)	6.4 kg (14 lbs)	"	"
9	9.5 kg (21 lbs)	6.8 kg (15 lbs)	"	9.6 m (380 in)
10	10.5 kg (23 lbs)	7.3 kg (16 lbs)	12.5 cm (5 in)	"
11	11.4 kg (25 lbs)	7.7 kg (17 lbs)	"	"
12	13.2 kg (29 lbs)	8.2 kg (18 lbs)	"	"
13	14.1 kg (31 lbs)	"	"	"
14	15.9 kg (35 lbs)	8.6 kg (19 lbs)	"	"
15		9.1 (20 lbs)	15 cm (6 in)	12.7 m (500 in)
16		9.5 (21 lbs)	"	"
17		10.0 kg (22 lbs)	"	"
18		"	"	" 500
19		"	"	"
20		10.5 kg (23 lbs)	"	"
21		"	"	"
22		10.9 kg (24 lbs)	"	"
23		11.4 kg (25 lbs)	"	"
24		"	"	"

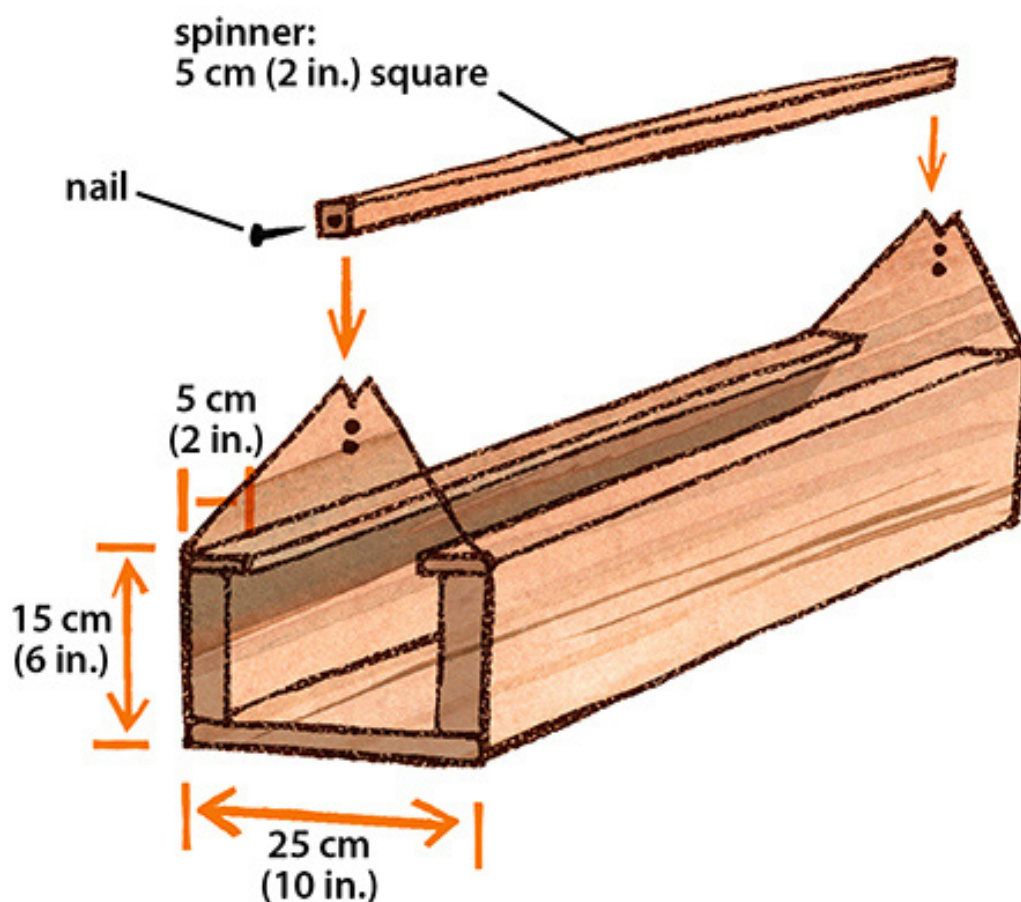
Ch 6: Housing and Equipment

Feeder Design

Wood Feeder

This wooden trough feeder is designed for layers 15 weeks or older. Dimensions of intermediate feeders should be adjusted for the age and size of the birds (see the feed space requirement table, above).

Figure 6-15: Wood Feeder

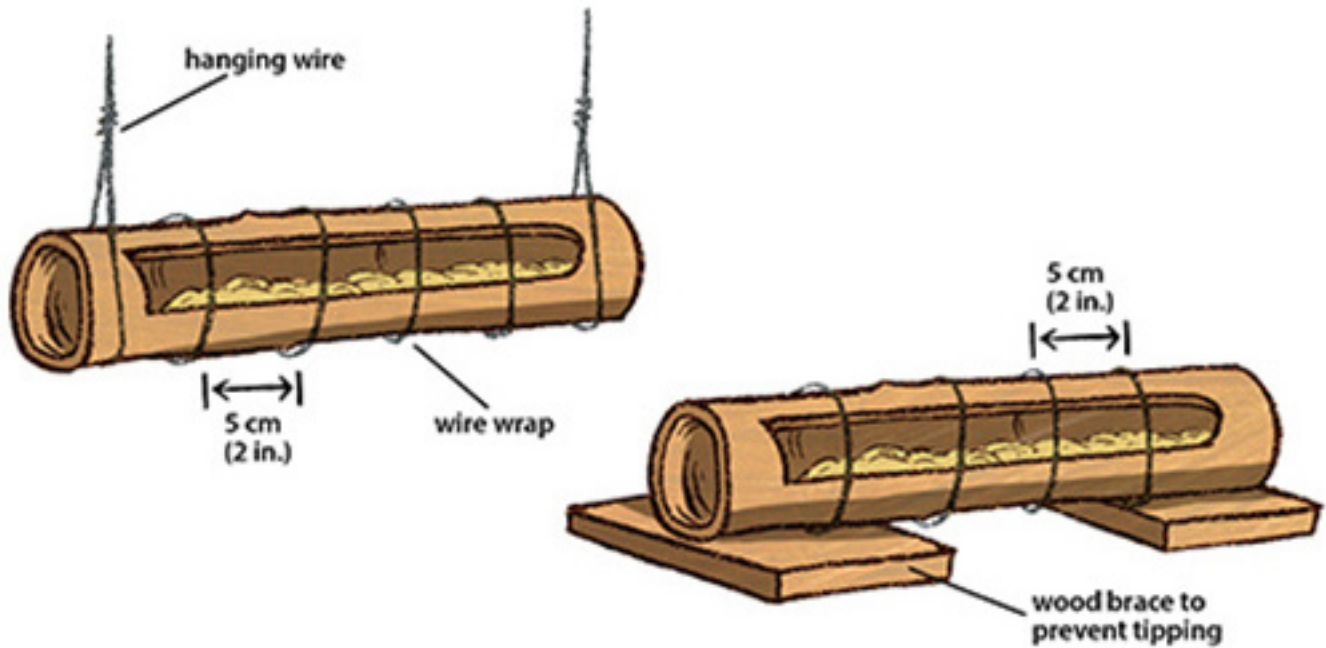


A spinner is made from a wooden rod with a metal rod attached to each end so it can rotate. The metal rod can be made easily, by cutting off the head of a nail.

Bamboo Feeders

Bamboo can be used for inexpensive feeders. To keep the birds out, use a spinner or tightly wrap the feeder with wire, as shown below.

Figure 6-16: Bamboo Feeders



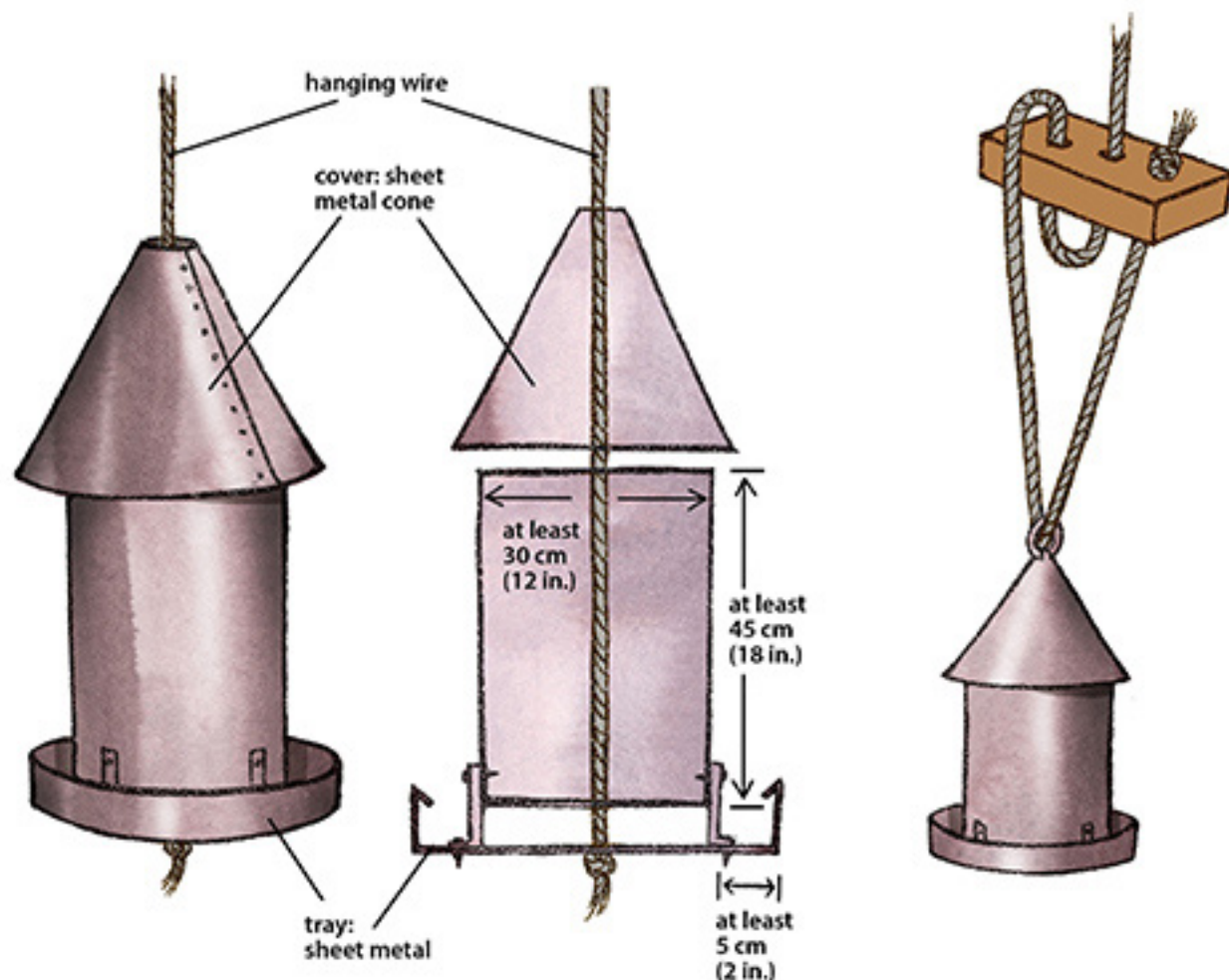
Dimensions depend upon the number and size of birds.

Hanging Feeder

Hanging feeders have several advantages: rats have difficulty getting into them, they supply feed continuously at the proper height, and it is easy to adjust their height. They can be made from large tin cans (sometimes available from restaurants) or from sheet metal.

Ch 6: Housing and Equipment

Figure 6-17: Hanging Metal Feeder

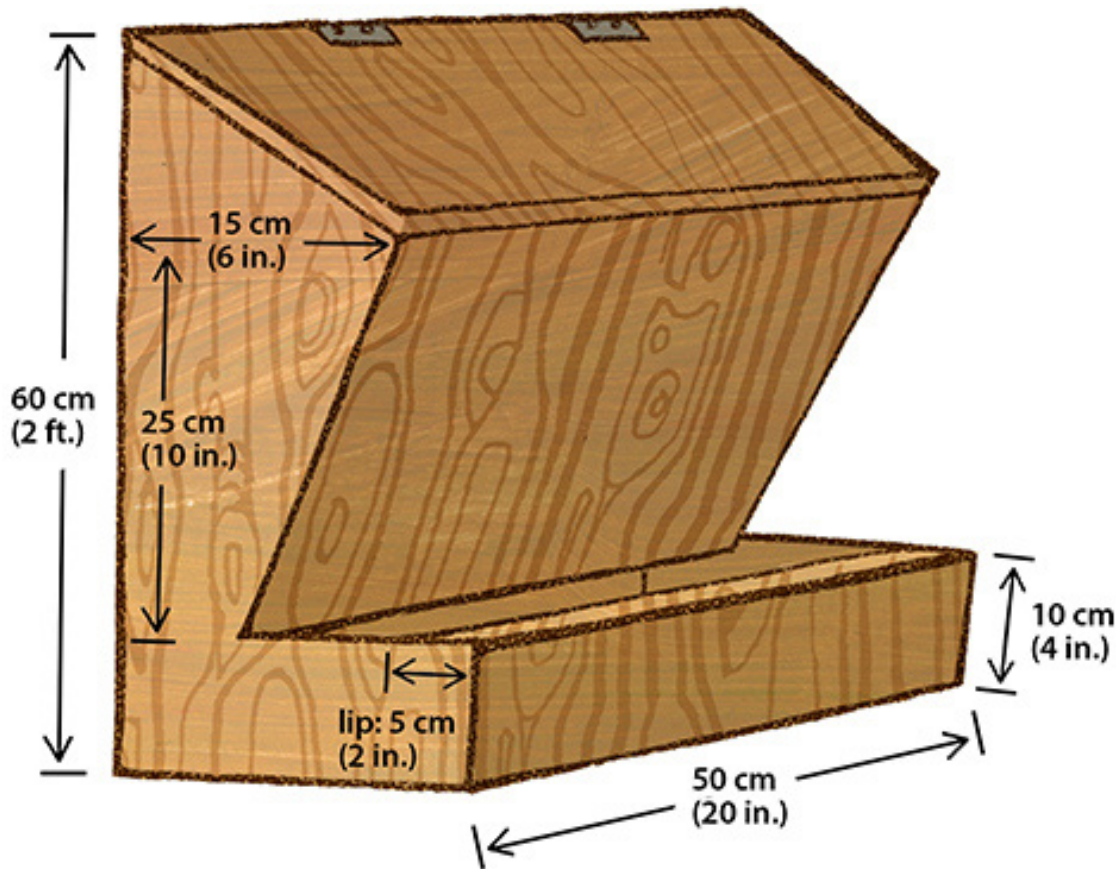


Grit Hoppers

Instead of teeth, birds have a muscular organ, the gizzard, to grind their food. To crush food well, gizzards must contain small, hard stones, or grit. Over time, the grit crumbles or dissolves and must be replaced. Country chickens, ranging free or in fenced-in yards, can usually find their own grit. The farmer must supply grit to contained birds.

Good grit stones are about the size of small peas and have a rough surface. Small river gravel that is not smooth makes excellent grit. Relatively inexpensive grit can also be purchased from commercial feed suppliers. Grit can be served in any container that the chickens cannot enter and contaminate. A grit hopper that can supply 200 chickens for about a week is illustrated below. Keep the cover closed so the grit remains clean. Make sure grit always is available or the chickens will not digest their feed well.

Figure 6-18: Grit Hopper



Oyster and Eggshell Hopper

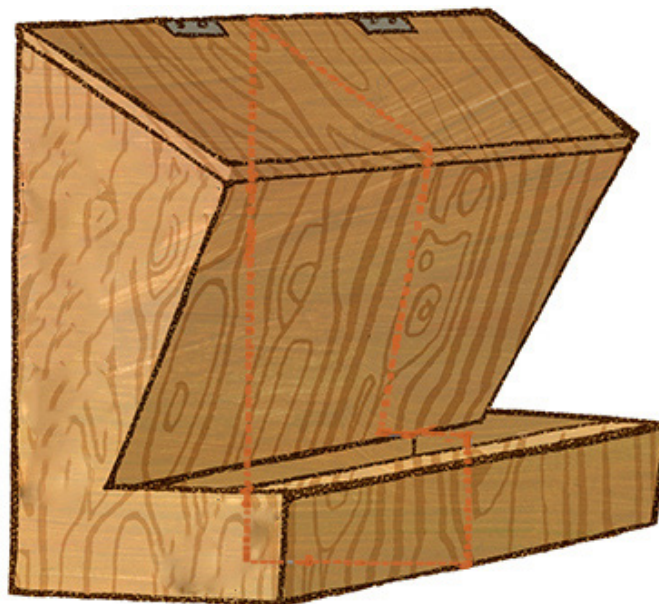
Chickens need a source of calcium to maintain their bodies, and laying hens need extra amounts to produce strong eggshells. The usual calcium source is crushed oyster shell or limestone, purchased commercially. Powdered limestone does not work well, because hens do not like to eat it. This can be supplemented with boiled and dried eggshells broken into very small pieces so the hens don't recognize what they are eating and start to eat their own eggs. The eggshells from a flock do not provide enough calcium to meet that flock's requirements. Keep a calcium supply always available and the chickens will take what they need.

Old hens require more calcium than young ones. Also, hens need more calcium in hot weather.

A calcium source can be included in a mixed feed or provided separately in a container similar to the grit hopper. It may be convenient to use a two-compartment hopper for grit and calcium, as shown below.

Ch 6: Housing and Equipment

Figure 6-19: Two-Compartment Grit and Calcium Hopper



Nests

Providing nests for laying hens helps keep eggs clean and reduces breakage. Baskets reinforced with sunbaked clay or cow dung can be used for nests (see below). Usually, clay is applied to the outside of the basket. Nests should be placed on the darkest side of the house, preferably where the morning sun will not hit them. Line them with fresh litter and keep it clean. Provide one nest for every five hens. In hot climates, nests should be well ventilated.

Nesting Boxes

With more than a few laying hens, the farmer will probably find that it pays to provide specially constructed nesting boxes. The concept is to enclose a volume of space about 0.028 cubic meters (1 cubic foot) per bird with wood, sheet metal, wire mesh, clay or mud bricks, or woven mats, and line it with litter.

Well-constructed boxes will stand up to frequent cleaning. Boxes may be placed on the floor, raised by supports, or attached to the wall. A set of boxes may have one, two, or three tiers. Any boxes above the floor should provide a perch in front where birds can alight before entering the nest. Ideally, there should be a means of closing the nests in the evening so birds don't roost in them and dirty them.

Figure 6-20: Individual Nesting Boxes

Photo c/o creativecommons.org

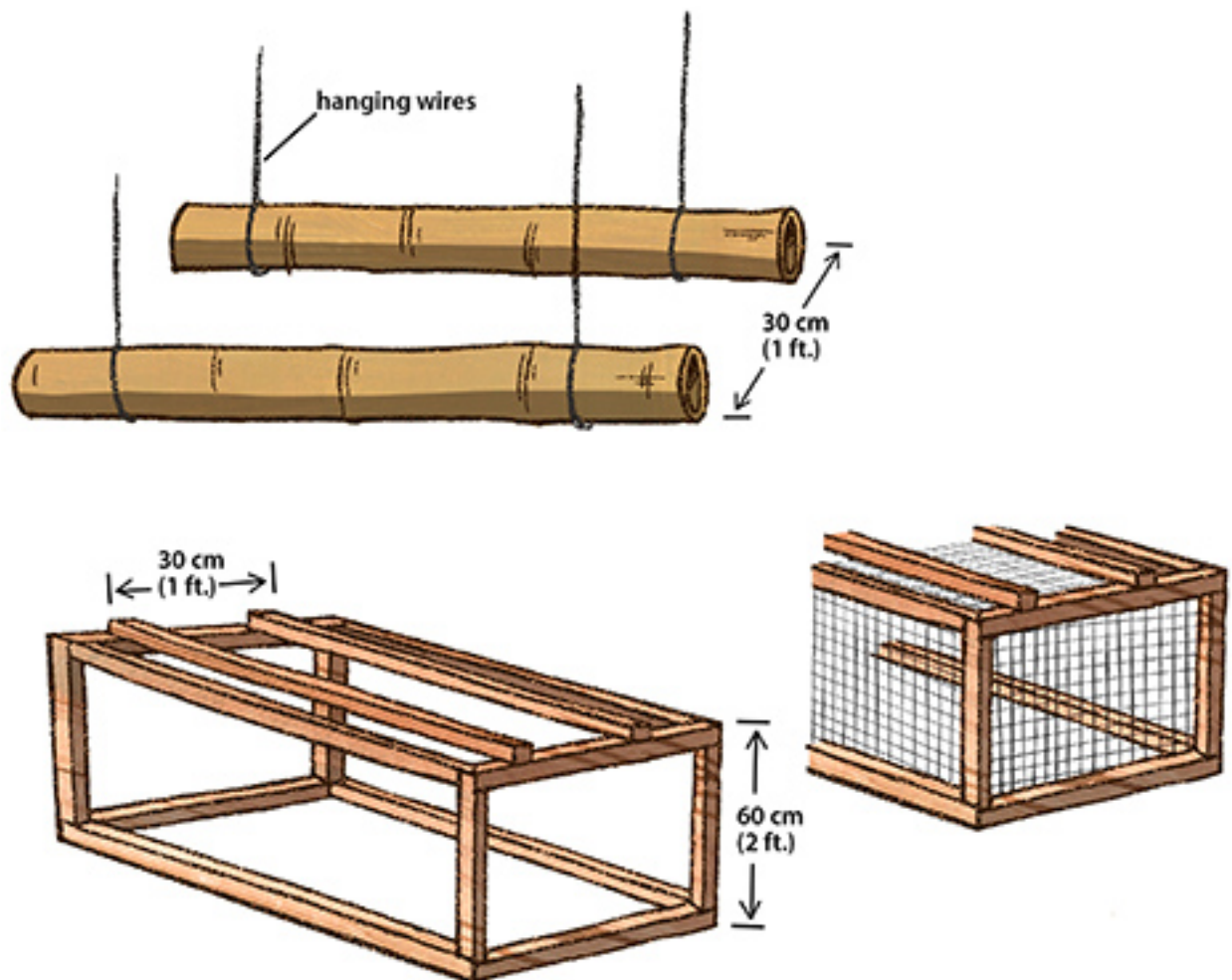


Two types of nest boxes could be used. Individual nest boxes (see Figure 6-20) are constructed so that only one hen can fit in one compartment at a time. Colony nest boxes are large enough to allow four or more hens to lay at once—at least .37 square meters (4 square feet) of floor space without dividers; however, these are not recommended because more eggs will be broken than with individual boxes.

Roosts

When they can, chickens prefer to spend the night roosting in trees. Contained birds don't need roosts, but the presence of roosts can help concentrate droppings, making sanitation easier. Building roosts takes time and money. If you use them, place a removable droppings board under them or screen off the area beneath. Clean the boards or the screened area often. Allow 20 centimeters (8 inches) of roost for each bird.

Figure 6-21: Roosts



Ch 7: Keeping Chickens Healthy

Chickens are subject to as many ailments as humans are. Some chicken and human diseases even have the same names, including pox, colds, cholera, typhoid, hepatitis, pneumonia, and bronchitis. Parasites (such as tapeworms, ticks, and lice) and poisonous substances (such as aflatoxin and botulism) attack both chickens and humans. A well-trained veterinarian, backed by a competent laboratory, can identify most chicken diseases with a good degree of certainty, but often cannot prescribe effective treatment, because some diseases cannot be treated, only prevented.

What hope is there for small-scale farmers and extensionists who lack the veterinarian's experience and equipment? Plenty. Good management of chickens with special attention to sanitation, quality of feed, and vaccinations greatly reduces the chances of diseases or parasites attacking the flock. Knowing about major health problems and how to treat them is important, but not as important as preventing these problems in the first place.

Health problems can occur even with good management, of course, and the farmer should be alert for them. A sick chick is inactive, doesn't stand erect, and may have runny eyes or dried traces of diarrhea around its vent. It may sleep in an odd position or walk with a strange gait. Older sick chickens show obvious signs of poor condition: thin, hunched bodies, scraggly feathers, wings hanging loosely, general weakness, and smaller size than the healthy members of the flock (assuming all members of the flock are the same age and breed, which is strongly recommended). Two major signs of health problems in a flock are if total feed consumption decreases, or if mortality exceeds 1 percent in any seven-day period. Observe your flock for deviations from normal for at least 15 minutes each day.

Even in a well-managed flock, you can expect to lose an average of 1 percent each month. In other words, if you start with 100 chicks, you should expect to have about 90 left at the end of a year. Some will die suddenly; others will show obvious signs of disease. Remove sick and dead chickens.

For small flocks of fewer than 50 chickens, use an isolation pen for the period of sickness. For larger operations, slaughter sick birds and perform a postmortem examination to see if the cause of sickness can be determined.

If mortality exceeds the 1 percent rate or if there are more than one or two sick chickens in a flock of 100, seek veterinary advice immediately.

Bury all dead chickens in a pit in the ground to eliminate any chance of disease transmission from these chickens. A dead-bird disposal pit should have a tight cover to prevent predators such as rats from getting at the chickens. If the farmer has a methane gas digester, dead chickens can be put in this, but feathers will have to be removed first, because they do not digest for many months. If this is done, burn the feathers.

Diseases

The innumerable diseases that can affect a chicken can be divided into three categories:

- Those prevented by locally recommended vaccines (such as Newcastle)
- Those prevented by or treated automatically in a good management schedule (such as coccidiosis)
- Those for which good sanitation and nutrition are the best means of prevention (such as cholera or coryza)

Prevention by Vaccination

Before doing any vaccinations, you should become familiar with the diseases that are prevalent in your area, or you may needlessly vaccinate for a nonexistent disease. Check first with local authorities. A vaccine—containing bacteria or viruses introduced into the body to produce immunity to a specific disease by causing the formation of antibodies—can be administered to chickens in a number of ways. Handle the birds swiftly but smoothly to minimize stress, but be sure that all receive the proper dosage.

Methods of vaccination:

- **Medicine or eye dropper:** Put a drop of vaccine in the bird's eye and wait for it to blink, or place a finger over one nostril, put the drop in the other nostril, and wait until the drop is breathed in.
- **Feather follicle:** Pull a few feathers from the bird's thigh and rub the feather follicles in the area with a vaccine-soaked cotton swab or brush.
- **Wing web stick:** Dip a web stick into vaccine and use it to puncture the skin on the underside of a wing. Be careful not to hit a vein. Always stick the same wing of all birds (either the left or the right wing) so you can check later for a scab, which shows the vaccine has been effective ("a take").
- **Drinking water:** Some vaccines are mixed into the flock's drinking water.
- **Intramuscular:** Use a syringe to inject the vaccine into the breast.

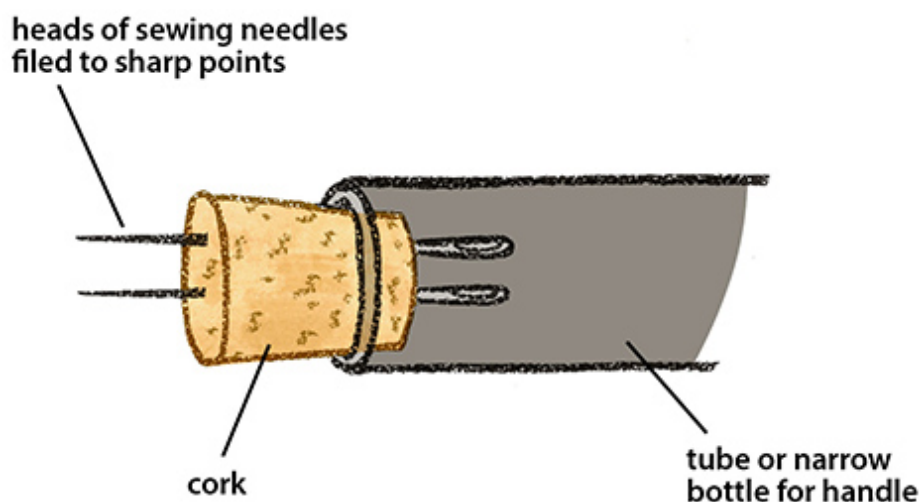
Be extremely careful with vaccines—they can kill birds. Store them according to directions; many need refrigeration. Mix them away from poultry just before using. Don't spill them on or near chickens. When working with large numbers of birds, have adequate help: if possible, the person mixing and giving the vaccines should not handle the birds. If you are using a live virus vaccine, tell neighboring farmers, because if they have not already vaccinated their birds, the live virus could spread the disease to their chickens. If one farmer vaccinates and the next does not, be certain there is no means of transmitting the disease to unvaccinated birds.

Ch 7: Keeping Chickens Healthy

Don't give more vaccine per bird than is recommended, and don't give less to "stretch" vaccine supplies. This is dangerous.

Administer mixed vaccine at once and get rid of the remainder—don't keep it overnight, as it will lose its effectiveness. Thoroughly sterilize any equipment you plan to use again (it is best to dispose of it and use new equipment). Change your clothes and disinfect your shoes before visiting other chickens.

Figure 7-1: Wing Web Stick



Diagnosis

Other than knowing the obvious symptoms of the most common chicken diseases and what to do about them, an inexperienced farmer should be very cautious about diagnosing a disease and attempting to cure it. Seek professional advice whenever possible.

Avian Flu

Cause: Virus transmitted by other chickens and other species of birds.

Symptoms: No disease or mild illness; may only cause mild signs such as ruffled feathers and a drop in egg production, and may not be detected. Severe cases can cause *cyanosis* (purplish-blue coloring) of wattles and comb; *edema* (fluid build-up) and swelling of head, eyelids, comb, wattles, and hocks; green diarrhea; blood-tinged discharge from nostrils; pinpoint hemorrhages (most easily seen on the feet and shanks); respiratory distress; and increased death losses in a flock.

Prevention/Treatment: Vaccination is not usually recommended because, although it may reduce initial losses, vaccinated birds may remain carriers if exposed to the infection. To be

Ch 7: Keeping Chickens Healthy

effective, inactivated vaccines must be the right subtype for the situation (H5 will not protect against H7, and vice versa). In outbreaks, a regime of slaughter, correct disposal of carcasses, cleaning, disinfection, isolation, and 21-day interval to re-stocking should be followed. Survivors can be expected to have a high degree of immunity but may harbor virulent virus.

Newcastle (Ranikhet) Disease

Newcastle is the disease most widely feared by poultry farmers around the world. When it strikes young chickens, mortality may be as high as 100 percent. In parts of Asia, it is known as Ranikhet disease.

Cause: Virus transmitted by other chickens and other species of birds.

Symptoms: Coughing, gasping, and raspy breathing, extreme nervousness, and distended crop. Inactivity, lack of coordination, drowsiness, huddling near a heat source, drooping head, partial paralysis, coma, and death. The presence of all these symptoms does not confirm the diagnosis—only lab tests can do that. Newcastle quite often appears as a respiratory condition before a nervous condition appears.

Postmortem signs: Mucus in trachea, possibly yellowed and thickened air sacs; possible hemorrhages in proventriculus.

Treatment: None.

Prevention: Most countries have vaccines available. A general rule of thumb used by many poultry experts is to vaccinate on a 4–4–4 schedule—meaning when the birds are 4 days old, 4 weeks old, and 4 months old—but you should use local recommendations.

Fowl Pox

Fowl pox is a disease that can attack birds when they are 3 to 5 months old. It is not necessary to vaccinate for this illness before the chicks are 5 weeks old. Pigeon pox vaccine is only needed to provide emergency treatment if there is an outbreak of fowl pox in an unvaccinated flock.

Figure 7-2: Puncturing the Wing Web

Photo c/o creativecommons.org



Ch 7: Keeping Chickens Healthy

Cause: Virus spread by insects, especially mosquitoes, and then by direct contact with infected chickens and wild birds.

Symptoms: Fowl pox most frequently attacks birds when they are 3 to 5 months old. There are two types:

- Dry pox or modular form, which generally appears as a wart or insect bite, causes swelling of comb, wattles, face, and sometimes the eye. By itself, dry pox does not usually cause much mortality.
- Wet, or diphtheritic, form begins with discharge from the eyes and nostrils, and then a cheesy material forms in the mouth. This can cause suffocation unless it is removed. Wet pox results in high mortality—up to 50 percent—and egg production in layers decreases substantially.

Postmortem signs: Mucus in trachea, possibly yellowed and thickened air sacs, and hemorrhages in the proventriculus.

Treatment: In an affected flock, if the birds have been observed daily, this disease can often be detected before many birds are affected. In this case, vaccinate the unaffected birds with fowl or pigeon pox vaccine immediately.

If a neighboring flock gets the disease, vaccinate all flocks in the area immediately. There is no treatment for chickens that already have fowl pox.

Prevention: Follow the recommendations of local authorities. In most cases, this means that if fowl pox is prevalent in an area, the best action is to vaccinate. Many experts suggest vaccinations around 6 weeks of age and again at 12 weeks.

Fowl Cholera

Cause: Bacteria spread by droppings of infected birds through contaminated soil, feed, or water. Vectors include wild birds and the feet of people and animals.

Symptoms: Two types of cholera affect chickens:

- Peracute or severe cholera: the only symptoms are dead birds.
- Acute and chronic: sudden, almost total lack of appetite; greenish-yellow diarrhea; difficulty breathing; high fever and increased thirst; head turning blue; enlarged, hot, swollen combs and wattles; affected birds feel very hot to the touch; swollen eyes and thick discharges from nasal passages similar to that found in coryza.

Ch 7: Keeping Chickens Healthy

Treatment: A recommended bactericide (sulpha drug) in feed and water may reduce mortality in an infected flock. Remove affected birds and change litter. Thoroughly disinfect equipment and house.

Prevention: Primarily, cleanliness. If vaccines are recommended, it may help to administer them in accordance with the recommendations of local authorities.

Infectious Bronchitis

Cause: Virus spread through air or via contaminated material.

Symptoms: In chicks: sneezing, gasping, mucus, clicking heard in throat, and discharge from nostrils and eyes. In layers: egg production drops abruptly by 10 to 50 percent, and remaining production is of poor quality (thin shells and misshapen, watery whites). In chicks, mortality may be 5 to 60 percent; in mature birds, up to 2 percent.

Treatment: None for the infection. Antibiotics can be given to lessen complications.

Prevention: Following nearby outbreaks, vaccines, if recommended by local authorities, can be used in accordance with their recommendations and schedules.

Laryngotracheitis

Cause: Virus—airborne or carried on clothing and equipment from infected birds.

Symptoms: Birds have extreme difficulty breathing, may stretch their necks when inhaling and droop their heads on their chests when exhaling; also may cough up bloody mucus. Mortality can range from 5 to 50 percent.

Treatment: None for the infection, but disease spreads slowly, so unaffected birds can be vaccinated.

Prevention: Never vaccinate where there is no history of the disease. If an outbreak occurs nearby and vaccine is available, use the schedule and methods recommended by local authorities.

Marek's Disease (Leukosis)

Cause: Virus spread through chicken dander (cells sloughed from feather follicles), the major component of chicken-house dust.

Ch 7: Keeping Chickens Healthy

Symptoms: Droopiness, poor feathering, and weight loss may be the only signs before death. Some birds are mildly to completely paralyzed; they lie on their sides and slowly starve. Mortality may be up to 1 percent per day for two to three weeks.

Treatment: None.

Prevention: Vaccination of day-old chicks, which is usually done by the breeder, if at all. Vaccinated egg-breed chicks are especially valuable.

Pullorum

Cause: Salmonella bacilla transmitted through the eggs from one generation to the next if parents are not salmonella-free. Can also be transmitted through visitors' feet, animals, contaminated feed, equipment, and wild birds.

Symptoms: In chicks: sudden deaths; other chicks droop wings and huddle near heat source; diarrhea is white, sticky, and foaming. Chicks may have 50 percent mortality. In acute outbreaks, adults are weak and depressed, and may have greenish-brown diarrhea.

Treatment: Sulfa-based drugs for market stock; do not use infected birds for breeding.

Prevention: Buy only certified pullorum-free chicks and implement sanitary management practices.

Coccidiosis

Cause: Nine species of coccidia (protozoan parasites) spread through contaminated food, water, or litter. Each species attacks a different portion of the intestines or ceca, an intestinal appendage. It is extremely difficult to isolate chickens from coccidia.

Symptoms: Signs of the disease will vary with the type of coccidia involved and the degree of immunity the flock has to that type. General indications: decrease in food consumption; birds hunch backs, droop tails, and ruffle feathers. Diarrhea may start and the loose droppings may be bloody (reddish-brown). Following bloody diarrhea, mortality may increase rapidly.

Postmortem results: In chickens less than 16 weeks old, red specks on interior wall of intestines (in a severe case, purple spots show through exterior wall); intestinal wall is thicker than normal. Other signs: Gray-white streaks on wall of upper intestine, pink or reddish substance on intestinal wall. In chicks under 9 weeks, ceca may be filled with blood and swollen to the size of a finger. For birds older than 16 weeks, a lab test is needed.

Ch 7: Keeping Chickens Healthy

Treatment: If a confirmed outbreak among chickens 1 to 12 weeks old is severe, treat immediately with locally recommended coccidiostats. These drugs come in many forms, many combinations, and under many names, both generic and proprietary. It is a good idea to switch from one type of drug to another each chicken cycle so local coccidia do not establish resistance to any particular type. Do not mix one with another, as this can be harmful. Follow the manufacturer's directions closely. Some effective coccidiostats are:

- Amprolium
- Amprolium plus ethopabate (not for laying chickens)
- Arsenobenzine: stop use five days before slaughter
- Glycarbylamide (not for laying chickens: stop use at least four days before slaughter)
- Dinitrodiphenyldisulfide
- Nicarbazin: stop use four days before slaughter
- Aklomide: stop use at least five days before slaughter
- Bithionol and methiotriazamide: stop use at least five days before slaughter
- 3,5, dinitro-o-toluamide (not for laying chickens)
- Sulfaquinoxaline

Other drugs that can be used as coccidiostats, though not as effective as those above, include terramycin, nidrafur, agribon, 3-Nitro, NF-180-furazolidone, nitrofurazone, phthalysulfacetamide (TSC), and sulfaethoxyypyridazine (SEZ).

Prevention: There are three ways to deal with coccidiosis:

- Natural development of immunity: Allow the flock to build immunity without administering any drugs, unless there is a severe outbreak. This works well when the flock is exposed only to low levels of coccidia. Under very dry conditions, there may not be enough infection present to develop immunity. In a very dry environment, sprinkle the litter with water at weekly intervals to maintain a constant exposure and immunity level in the flock. This may be necessary where a well-ventilated poultry house is located in an area where the humidity of the outside air is consistently under 50 percent. Sudden, massive invasions of coccidia can hurt the flock severely, and large doses of medication can prevent future immunity.
- Complete prevention: Give the flock the recommended medium level of coccidiostat through its first 15 weeks. This most likely will prevent the birds from contracting coccidiosis at all, but they will not develop immunity. Use this method only for broilers and for layers that will be kept in wire cages.
- Immunity plus treatment: Use the low-level dosage recommended during the first 15 weeks. This should allow the birds to develop some immunity, and they may not need any further attention. In case of a mild outbreak, treat broilers and layers going

Ch 7: Keeping Chickens Healthy

to cages with the largest recommended dosage. Treat layers that will be kept on litter with heavy doses only during severe outbreaks so they otherwise build up as much immunity as they can. This method is the safest overall, and would be the best single recommendation for small and medium-sized flocks.

Infectious Coryza (Cold)

Cause: A bacteria, spread from chronic or acutely infected birds to healthy birds.

Symptoms: Foul-smelling discharge from eyes and nostrils, coughing, sneezing, difficulty breathing; chicks shake their heads as if trying to get rid of something; often found where different ages of birds are kept together and birds are overcrowded. Rare in adults, but when found, egg production drops and feed consumption decreases. Mortality is rare.

Treatment: Sulfa drugs in the feed or water will eliminate the problem within two weeks if other diseases or complications are not present.

Prevention: Do not mix birds of different ages. Cull all birds found with swollen head parts before they infect the rest of the flock. There may be bacterins or vaccinations available in some countries, but not most. Use proper management practices.

Parasites

Parasites, both internal and external, weaken and can kill chickens. In addition to getting its food from a chicken's body, a parasite can carry disease or increase the bird's susceptibility to disease.

Worms

At least nine species of worms may infect various internal parts of chickens. Chief among them are roundworms, cecal worms, and tapeworms. Worms are spread through feces or through a variety of intermediate hosts, including snails, slugs, earthworms, flies, cockroaches, and other insects.

Symptoms: Initial increase in feed consumption with little or no weight gain. In severe cases, chickens lose weight rapidly. Laying chickens produce fewer eggs.

Postmortem results: Large roundworms, found in middle of small intestine, are yellow-white, from 4 to 7.5 centimeters (1.5 to 3 inches) long, and comparatively thick-bodied. Cecal worms, found in blind ends of the ceca, are white and about 1.25 centimeters (0.5 inches) long.

Ch 7: Keeping Chickens Healthy

Tapeworms, found in the small intestine, are flat, white, ribbon-like, and segmented. They vary in size from microscopic to 15-17.5 centimeters (6 to 7 inches).

Treatment: Each type of worm requires a specific drug: piperazine for roundworms, phenothiazine for cecal worms, and dibutyltin dilaurate for tapeworms. Some manufacturers combine one or more of these drugs in a single medication. Treat as directed for major infestations.

Prevention: Primarily, sanitation. Make sure litter is replaced between flocks, keep wild birds out of the house, use insecticides against cockroaches and other intermediate hosts, and do not feed snails or slugs to chickens. If you suspect that worms are present (they probably are), treat broilers at 4 weeks of age and every two months thereafter; treat layers at 10 weeks and every two months thereafter.

Lice

The most common poultry parasites are lice. They spend their entire life cycle on the body of the bird.

Symptoms: Skin irritation, scabs, ruffled feathers, diarrhea, small weight gains, or decrease in egg production; some dead young chickens when infestations are heavy.

Treatment: Infested chickens on raised floors, in cages, or ranging free should be sprayed or dusted with malathion, carbaryl, pyrethins, naled, coumaphos, or similar preparations, using a crop sprayer. In deep-litter systems, the litter and all equipment except feeders and waterers can be sprayed or dusted. Where chemicals are too expensive or not available, some farmers use a mixture of ashes with sulphur powder or gunpowder obtained from the local market. About 20 grams of sulphur powder to 1 kilogram of cold ashes or a 1:50 ratio is said to be quite effective.

Prevention: Keep nests clean. If you use roosts, paint them with nicotine sulfate—the bird's body heat will create fumes that kill the lice. Some farmers use creosote in the cracks and joints of roosts (carbolineum).

Mites

Mites are almost invisible, spiderlike creatures that come from various species. Some stay on the birds continuously, while others attack only at night.

Figure 7-3: One Kind of Chicken Louse (*Goniodes Gigas*)

Photo c/o creativecommons.org



Ch 7: Keeping Chickens Healthy

Symptoms: Scaly leg mite: birds are lame, legs are swollen, scaly, and crusted. Red mites (nocturnal): loss of weight and egg production, anemia. Depluming mites (base of feathers): birds pull feathers out to relieve itching.

Treatment: None for scaly leg—cull affected birds. For other mites, use the same treatment as for lice.

Prevention: Same as for lice.

Ticks

In addition to sucking blood, fowl ticks (flat, egg-shaped, reddish-brown bugs) can carry spirochetosis, or tick fever, which results in rapid death without any other symptoms. Ticks are usually found only in hot, dry areas. They spend part of the time in cracks in walls, roosts, and other wooden equipment and are very hard to find. If you suspect their presence, pry into cracked boards with a knife and examine closely.

Symptoms: Loss of appetite and weight, possible anemia.

Treatment: Same as for lice, then aggressively attack infestation, removing litter and equipment, filling in cracks in feeders and elsewhere, cleaning and spraying everything, and repeating that twice at two-week intervals and once six months later. If the roof is thatch, change it. If the house is old, consider building a new one. Some farmers go over cement and other non-flammable materials with a blowtorch.

Prevention: Sheet-metal feeders, nesting boxes, and other equipment are easier to keep free of ticks than wooden ones. Roosts hung by wire are safer than those on stands.

Other Health Problems

Feed that is improperly stored or kept too long can go bad, causing botulism or other food poisoning. Be very careful when using insecticides, rat poisons, gasoline (petrol) engines, and other possible poison sources around chickens. Crowded or improperly cared-for chickens may start pecking each other.

Performing a Postmortem Examination

Looking carefully at the body and insides of a chicken that has died of unknown reasons may help determine those reasons. Very sick birds with no hope of recovery should be killed using locally approved methods or by dislocating their necks.

Ch 7: Keeping Chickens Healthy

It will be helpful to examine the insides and outsides of as many healthy chickens as you can when they are slaughtered. Note the position, size, color, and texture of all internal organs. Then, when you work on a sick bird, you will be better prepared to spot abnormalities.

This manual does not attempt to give instructions on how to diagnose most diseases—that is best done by special publications with color illustrations—but there are some signs you should look for.

Killing a Chicken

Stretch the neck and bend back around thumb.

Examine a bird as soon after death as possible, before body conditions have changed. As you work, take good notes. Your notes will help veterinarians or lab technicians, if they are available, to identify the problem. Ideally, you would take or send a few sick but still-living chickens to the vet or lab for diagnosis, but this often is impractical. In a postmortem, first examine the outside of the bird. Look for lice or mites, particularly around the vent, that may have contributed to the death. Discolored head parts, such as the comb and wattles, are indications of a number of diseases. Straighten the neck, pull the tongue, and examine the throat and windpipe for cheesy nodules (lumps), which are signs of pox. Check the nostrils for a putrid smell. If the legs are rough, scaly, and swollen, it may indicate mites. Look for swollen leg and wing joints and excessive abdominal fat. Also, look for blackened spots, which can be caused by scorpion stings.

Open the bird carefully. With a knife or shears, cut through the side of the mouth and esophagus. Look for the lesions (injured areas) of pox, fungus, excess blood or mucus, and other abnormalities and foreign matter and nodules. Slit the larynx and trachea, looking for excess mucus, inflammation, blood, and cheesy matter.

To look inside the bird, first slit the skin over the hip joints and dislocate them so the body lies flat. Puncture and cut the skin from just below the point of the breastbone to the head. Pull the skin flaps aside to bare the breast. With heavy shears, cut through the heavy bones and ribs on both sides of the keel (center ridge of breastbone), and remove the keel and breast muscle. Do this with care or you will damage the internal organs. Check for fluid in the body cavity. In females, check the body cavity for broken egg yolks (this will show as a black fluid if a broken yolk has been in body cavity for a while).

Figure 7-4: Stretching Neck

Photo c/o Peace Corps



Ch 7: Keeping Chickens Healthy

Slit the crop, remove food (noting if it smells sour), and examine the lining for worms, fungus, and other problems. Examine the liver, noting its color (normally dark brown) and looking for lesions or nodules (soft ones may indicate leukosis). Check the heart for lesions, hemorrhages on the fat, and cheesy matter or fluid inside. Examine the spleen and bronchial tubes for lesions and nodules. Note the color and texture of the lungs (normal, bright red and spongy, will float in water). Look for fluid (pneumonia), tumors, nodules, and congestion (dark red, will sink in water).

Remove the intestines and look for tumors, nodules, or hemorrhages. Slit the intestines to check for worms and other problems. Thickened intestinal walls may indicate microscopic worms or coccidiosis. Also look for blood, inflammation, and excess mucus. If you find blood in the ceca, look for cheesy matter, scarred lining, and cecal worms.

Open the proventriculus (true stomach, located at the joining of the esophagus and gizzard), checking for hemorrhages, worms, or inflammation. Slit the gizzard, looking for erosion. Gizzard erosion is most often caused by a nutritional deficiency and is indicated by ulcers and/or peeling of the gizzard lining. Check the kidneys for urates (white material) in internal passages. Examine the brachial nerves—if swollen, this may indicate leukosis. Note gallbladder size and color (normally green). In a layer, check the ovary and oviduct for excess fat and ruptures (breaks) that leak egg yolk into other body areas.

For every animal, there is an optimum amount and balance of foods or nutrients that will produce peak physical condition, growth rates, and, in the case of chickens, productivity. It is important to understand that both amount and balance are important in attaining maximum productivity. It is not enough to feed a layer all she can eat. A chicken would like to eat many fresh greens and corn because these things appeal to it (chickens can't taste) but, as with humans, what appeals most is often not what is best for the well-being of the chicken—or, in turn, for the poultry farmer. Thus, proper nutrition, proper balance, and control by the farmer of what the chicken takes in are needed. A frequent mistake in poultry feeding is to feed a nutritionally balanced feed and then ruin that balance by feeding excessive amounts of fresh greens and cereal grains on the side. This practice is only all right if the feeding program includes these items in formulating the final balance.

Because chickens have a short life cycle and are easily contained, many scientists have studied how different diets affect them. Much has been learned—too much to cover in this manual. In improving breed operations, the chicken farmer will most likely spend more money on feed than on everything else in the operation combined. For this reason, it is important that care be taken in choosing a feeding plan. There must be an assured source of good feed for the birds, either locally grown or commercially prepared. Commercial feeds are the easiest to work with but in some remote locations, they may be too expensive or simply not available. Where commercial feeds are available and being used successfully by some farmers, they are most certainly the choice for all farmers.

The concept of “too expensive” should be explained. How much profit can be made using a feed is more important than the cost of the feed itself. A steady supply of a well-balanced feed may result in more per-bird profit than a feed costs half as much but is not always available or is not properly balanced in nutritional content.

If good commercial feed is not available or is too expensive, the next best alternative for improved-breed operations is to consider mixing local ingredients with a “protein concentrate” and vitamin/mineral mixture. Protein concentrates are often available near urban and coastal areas, where they are either imported or mixed locally using fish or other protein sources. These concentrates can be transported to more remote areas and mixed with local maize, rice polish, tapioca, tubers, and other high carbohydrate ingredients.

The last alternative is to mix feed using only locally available ingredients. The specific approach taken in meeting nutritional needs of poultry depends on several factors:

- **Type of chicken:** Improved breeds do not produce well unless their feed contains a proper nutrient balance. Country chickens can withstand a varied diet and survive under less than ideal feeding conditions. Country chickens may do quite well on locally produced (noncommercial) feed because these birds are low producers, but they, too, will grow faster and produce better if food intake is improved.

Ch 8: Feed and Nutrition

- **Size of operation:** If a farmer has only 100 chickens, it is probably more costly and certainly more time-consuming to mix feed than to purchase from a commercial source. Additionally, the smaller the poultry operation, the less reliable or steady will be the supply of necessary ingredients. If there are 20 or so small-scale farmers, a poultry cooperative that has feed-mixing and storage services could be an answer.
- **Climatic conditions:** In hot, humid climates, feed cannot be stored more than a month without spoilage. Vitamins deteriorate rapidly in hot climates and must be used within a few days after purchase, unless refrigeration is available. Large feed-mixing operations can purchase and use vitamins rapidly. All ingredients that contain fat must also be used quickly. If a commercial antioxidant is available and not too costly, buy it and mix with any ingredients that contain fat.
- **Availability of commercial feeds:** In addition to the costs mentioned above, other factors in favor of commercial feeds must be considered. The commercial supplier takes care of ingredient purchasing, price negotiation, transport, advance planning, storage of buffer stock, and contracting with ingredient suppliers. If commercial feed is available and you cannot determine where ingredients will come from a year from now for your own mixing operation, you probably should rely on the commercial source. You must be certain you will have the proper mix of ingredients to provide all of the necessary nutrients at all times.
- **Type of operation:** A broiler operation requires a steady supply of feed for only 7 to 10 weeks. Ingredients may be available for short periods in line with harvest and grain milling, fishing times, and other seasonal variations. Layer operations are different. The feed must be available without interruption throughout the year—and year after year—to be successful.

Commercial Feeds

Except in some remote areas, farmers will probably use commercial feeds for improved-breed operations. In most places, commercial feed comes in the form of a dry mixture called mash. Whether commercial or home-mixed, feeds must match the different protein needs of chicks, growers (the stage between chick and adult), broilers, and layers. It is the protein content that distinguishes what feed should be given to the different ages and types of chicken.

Commercial feeds are sold with the following designations:

- Chick (“starter”) mash: Fed from a chick’s hatching until 8 weeks, starter mash contains 20 percent protein.
- Grower mash: Fed from 9 to 20 weeks, grower mash contains 16 percent protein.
- Broiler mash: From hatching to sale, broilers need large amounts of protein for rapid growth. Their feed contains 22 percent protein.

- Layer mash: Through the laying period, hens receive mash containing 16 to 18 percent protein. (This is usually the recommended level, although research indicates that 15 percent protein is sufficient to maintain a high level of production, as long as the essential amino acid content is balanced. Where protein costs are very high, it may be wise to try the 15 percent level. Otherwise, use 16 to 17 percent to allow a margin of security.)

If you use a commercial feed, you may want to have it checked occasionally by a laboratory to ensure it continues to have the proper content. Your local government may have this capacity.

Some farmers using commercial feed will want to give greens and cereal grains to their chickens. Greens are sometimes used to reduce cannibalism or make the egg yolks darker in color. If greens are used, try to encourage use of high protein types such as alfalfa, clover, bean, pea, and lentil greens. Discourage use of cereal grains unless the amount fed is included in the feed mixing plans. Remember, a chicken can eat only a certain amount of feed. Every grain of corn, rice, etc. (which contains almost no protein) eaten reduces the intake of protein, vitamins, and minerals contained in the balanced ration.

Feeding Methods

Among the ways of feeding chickens are:

- Whole-grain feeders often are used for whole grain, by itself or mixed with other nutrients; or whole grains are sometimes scattered in the litter. The whole-grain method is not recommended.
- Wet mash: Chickens usually eat more wet mash than dry mash because they like its consistency. However, wet mashes go bad very quickly, particularly in hot weather. If wet mash is fed to increase feed and water consumption in hot weather, feed only an amount that will be consumed within two hours.
- Dry mash: When it is well-balanced and stored properly, dry mash usually is the best way of feeding contained chickens.
- Pellets or crumbles: Commercial mixtures in pellet or crumble form are excellent but usually too expensive.
- Home-mixed feeds: The decision of whether to mix feed or use a commercial source has already been discussed.

These factors should be reviewed:

- Economics: Is it really less expensive and/or more profitable to mix feed?
- Logistics: Will there be a reliable supply of ingredients available so that the proper mixture(s) is available year-round?

Ch 8: Feed and Nutrition

- **Equipment:** Is feed-mixing equipment available? If not, can it be made locally?
- **Technology:** Will provisions be made to ensure that the knowledge required for proper feed mixing stays in the local area?
- Is commercial feed on par with what you can mix yourself? Does the commercial seller do a consistent job in preparing the feed?
- If it is cheaper and feasible to mix balanced feeds, the process is not too difficult to learn. The problem of a continuous supply of ingredients is the main concern. Mixing feed takes time and patience, especially in formulating rations.

If you decide to try mixing your own feed, you will need to know the nutrient requirements of chickens, something about what those nutrients are, sources of nutrients, how to formulate a balanced ration, and the mechanics of mixing the various nutritive ingredients properly. Some ingredients contain toxic substances, others too much fiber, and you will need to know about avoiding excessive inclusion of these in your feed mixtures. Finally, once mixed, feed must be properly stored. Much of the information in this feed mixing section will be included in the appendices.

Nutrient Requirements of Poultry

Energy

Birds require energy, measured in calories, to move, eat, digest, grow, maintain body temperature, and produce eggs. Chickens get energy from:

- **Carbohydrates:** Grain, roots, tubers, and other starchy foods and sugars provide carbohydrates, the main source of energy in most balanced rations. When a chicken eats starch, the large, insoluble molecules are broken down into glucose (a sugar). This process, digestion, is brought about by the action of digestive enzymes, which are secreted into the intestinal tract. Once formed, glucose is absorbed through the intestinal wall into the bloodstream and the cells of the body. Carbohydrates can be divided into two categories:
 - Nitrogen-free extract is easily digestible to form glucose, an energy-rich material (starch).
 - Crude fiber-cellulose and other difficult-to-digest materials: alfalfa, sorghum, bran, and oats. Crude fiber content of feed ingredients must be considered in reference to formulation. Too much crude fiber is usually what you must watch for. If the diet contains too much, the chicken will not be able to eat enough feed to meet its energy, protein, and other needs. A common problem in many countries is using too much rice bran in the feed. Rice bran is a good, inexpensive ingredient, but

it often has a high fiber content. If possible, mixed feed should not contain more than 5 to 7 percent crude fiber.

- Fats have more than twice the energy value of carbohydrates. Fats are usually too expensive for use in poultry feeds because of the demand for human consumption. Fats also break down rapidly, causing feed spoilage. The more fat in the feed, the less time it can be safely stored. Feed spoiled due to breakdown of fat is rancid. Feeds containing fats are fishmeal and peanut meal.

Not all energy eaten by the chicken is used. The energy that can be used is *metabolizable* energy. Other energy is ejected in the feces. The specific energy requirements of chickens depend on age, production level (in layers), environmental conditions (degree of confinement, temperature), and other factors. For feed formulation, energy requirements for the different ages of chickens are shown in the table below.

Table 8-1: Metabolizable Energy

	Calories/lb.	Calories/kg.
0–8 weeks	1,250	2,750
8–20 weeks	1,280	2,815
20 weeks on	1,335	2,950

Protein

Protein consists of various combinations of amino acids. Amino acids are essential for tissue building and other body functions. Essential amino acids cannot be made by the chickens. High-quality protein sources are those that contain larger amounts of the essential amino acids. Those that are low in essential amino acids are low in protein quality. Animal proteins, such as fishmeal and meat meal, are high quality, and vegetable proteins are considered low quality. See Appendix E for protein and amino acid requirements.

Of the 13 amino acids listed in Appendix E, only arginine, lysine, methionine, cysteine, and tryptophan are of importance in feed formulation, because they are the most limited in many protein sources. Therefore, it is difficult to meet the minimum requirements of these essential nutrients. Mixed feed could be deficient in these five amino acids even if the total protein content of the feed is adequate. Of these, requirements for lysine, methionine, and cysteine are the most important and should be met first, because they are the most difficult to meet. It is likely that all other amino acid requirements will be in a feed that has enough of these three. In order to meet the minimum requirements of these amino acids, it is likely that you will need at least one animal protein source.

Ch 8: Feed and Nutrition

Vitamins

Vitamins are those organic compounds, required in extremely small quantities, that are essential for normal growth, health, and productivity.

- Vitamin A: Requirements are expressed in United States Pharmacopoeia (U.S.P.) units, which are the same as International Units (I.U.). Vitamin A is easily destroyed by heat, sunlight, and contact with air, minerals, or rancid oils. Vitamin A is found in corn, sorghum, soybean, alfalfa, and all green leafy vegetables.
- Vitamin D: Requirements are expressed in International Chick Units (I.C.U.), which measure only the quantity of D3 and not D2 because chickens can utilize only D3. Chickens under daily sunlight can make their own D3. Other chickens must have D3 in their feed. Use of artificial Vitamin D3 is usually necessary for contained units.
- Vitamin E: Because cereal grains contain a large amount of Vitamin E, deficiency is not likely in most poultry feeds.
- Riboflavin: Feeds with only cereal grains in the mix are probably deficient in riboflavin.
- Pantothenic acid: Rations with enough riboflavin will have enough pantothenic acid.
- Other vitamins: Vitamin K, niacin, thiamin, pyridoxin, biotin, and choline are other vitamins required by chickens, but deficiency is not probable in an otherwise balanced feed mix.

Minerals

Minerals are basic elements required for many life support functions. Not all the necessary minerals will be found in an otherwise balanced feed. Thus, mineral supplements must be added (see Appendix E).

Salt will have to be added to the feed mix unless fishmeal with a very high salt content is included in the mix.

Calcium and phosphorus are of particular concern, which most certainly will have to be provided separately for laying hens.

Non-nutrient Feed Substances

Grit: Consisting of small stones that are used in the gizzard of the chicken to grind up feed, grit is usually provided in a feeder separate from the mash.

Water: Necessary for all life.

Medications: To control coccidiosis, medications (coccidiostats) often are mixed into the feed. Antibiotics are sometimes included at very low levels in feed for growth promotion. When used for medical purposes, high levels for short periods for specific disease control is recommended. Antibiotics are not used for disease prevention, because if they are fed at a constant level over an extended period, antibiotic-resistant bacteria will result. Antibiotics are not used for growth stimulation after the age of 20 weeks.

Ingredient Use Limits

Appendix E contains a list of ingredients that should be used in only limited amounts in a feed mix. Some reasons for this limitation are:

- Crude fiber: Content in the feed will be too high if more than the recommended amount of some ingredients is used.
- Toxins: Cottonseed meal contains a toxin and should be used only in limited amounts. Soybean meal also contains toxins unless it is heat-treated.
- Palatability: Excessive use of some ingredients—or texture (too powdery or gummy)—will make the feed unpalatable to the chickens, resulting in lower feed consumption.
- Fishy tasting eggs: Will result if too much fishmeal is used.
- Poor nutrient balance: Too much of any ingredient (more than 50 percent rice polish, for example) will make it difficult to balance the ration. The listed amounts are given in some cases to simply help you in attaining a balanced ration.

Sources of Feed Nutrients

The charts in Appendix D list the amount of nutrients contained in 33 sources. Using the nutrient requirements listed in the appendices and the methods outlined on the following pages, you can calculate a balanced feed. You can add your own list of ingredients to use as nutrient sources, including termites; meat scraps from a local slaughterhouse to cook, dry in the sun, and grind up; bananas; papaya; breadfruit; ipil-ipil (*Leucena* sp.); or winged beans. Consult with local authorities about unconventional ingredients to ensure they are safe and recommended.

Formulating a Ration

Arriving at a balanced chicken feed (ration) requires a considerable amount of trial and error, patience, and determination, but with a good formula, the farmer will save money and control feed costs, which is the farmer's major expense.

Ch 8: Feed and Nutrition

Become familiar with the price, nutritive value, availability, and other characteristics of all actual and potential feed in your area. If they are not listed on the feed formulation charts, a local nutritionist may have information.

Steps in formulating a feed are:

1. Start by satisfying the protein requirements for both quantity and quality (amounts of essential amino acids). To come close, use one animal source and one vegetable protein source. Be particularly concerned with meeting the requirements for lysine and methionine (methionine and cysteine will do in place of methionine alone). Meeting requirements for lysine and methionine are generally the most difficult, which is why they are the first to be balanced. While calculating protein requirements, also look for high-energy, low-cost carbohydrate sources for energy, such as maize (corn), wheat, cassava flour, and rice polishings. Some protein will be found in these sources, reducing total feed costs. Once the lysine and methionine requirements have been met, check to ensure all other essential amino acid requirements are met.
2. Next, balance the protein and energy contents. Poultry eat primarily to meet their energy needs. If the ration is too high in energy, the chickens will eat less feed, thus meeting their energy needs but not their other needs—especially for protein. In such a diet, the protein content should be increased. It is safer to exceed minimum protein than fall short. In this step, also calculate the total crude fiber content of the feed. Try to keep it below 5 percent.

Example: If feed for chicks (20 percent protein requirement) has 3,000 calories per kilograms (1,373 calories per pound), which is more than the 2,750 calories (1,250) needed, protein content must be increased to 21.9 percent.

Figure 8-1: Calories per Kilogram (per lb.)

$$\frac{\text{calorie requirement}}{\text{calorie content}} = \frac{2,750 \text{ (1,250) } 20\% \text{ protein requirement}}{3,000(1,373) 21.9\% \text{ adjusted protein level adjusted for energy content}}$$

Keep the ratio of calories to protein in line with the needs of the birds. Try to stay within 2 percent of the ratio.

Calorie-to-Protein Ratio

For simplicity, the calorie-to-protein ratio is calculated by dividing the number of percentage points in the protein requirement of a given age or type of bird. The resulting number, or ratio, is useful only as a guideline for checking to be sure you have enough protein in the feed. Otherwise, the ratio is meaningless.

Ch 8: Feed and Nutrition

Example: For chick feed, you need at least 2,750 calories per kilograms and 20 percent protein. The calorie/protein ratio is:

$$2,750/20 = 137 \text{ calories/protein ratio}$$

In the prior example, we had 3,000 calories and a 20 percent protein requirement. To test the balance between protein and energy, the calorie/protein ratio is: $3,000/20 = 150$ calories/protein.

Since the proper ratio is 137, the protein content must be adjusted up to 21.9 percent, resulting in $3,000/21.9 = 137$, the correct ratio.

If the calcium and phosphorus in your formula is low, add limestone, dicalcium phosphate, or bone meal to meet requirements. For the birds to use both effectively, have about twice as much calcium as phosphorus in the feed. You only need about 60 percent of the calcium requirement in the feed if the flock has access to a calcium-source hopper.

Most foods, especially fish or meat meal, contain some salt. Therefore, add about 0.25 percent salt to the ration—that is, 250 grams per 100 kilograms (4 ounces per 100 pounds).

Balancing the vitamin and mineral contents of foods requires many calculations. An easier and accepted way to meet these needs is with a commercial vitamin-mineral supplement. If you follow the supplement's directions, the birds get enough of their needs without any harmful excesses.

Table 8-2: Example of Feed Formulation for Chicks

Assume the following is available:

# Source	Cost		Percentage of protein	Protein cost	
	100 kg	100 pounds		per kg	per lb.
Carbohydrate:					
Rice polish	\$ 4.95	\$ 2.25	11	--	--
Sorghum	8.25	3.75	9	--	--
Maize (corn)	9.90	4.50	8.5	--	--
Protein:					
Cottonseed meal	7.70	3.50	44	18¢	8¢
Soybean meal	17.60	8.00	50	35	16
Fish meal	24.20	11.00	60	40	18

Ch 8: Feed and Nutrition

Balance the ration's protein quantity and quality. Chicks need at least 20 percent protein, 1.1 percent lysine, and 0.75 methionine (or methionine + cystine) in a ration containing 2,750 calories of metabolizable energy per kilograms (1,250 calories per pound). Cottonseed meal is the cheapest protein source, but it cannot be used for more than 15 percent of the feed. Soybean meal is the next cheapest and will help balance the relatively low lysine content of the cottonseed meal. All three carbohydrate sources supply about equal amounts of energy, and their protein contents are about the same.

Therefore, in this example use rice polish at near its maximum rate (50 percent) because it is the cheapest. Although maize supplies much Vitamin A, it still is too expensive. Instead, use sorghum as the second carbohydrate source.

Table 8-3: Sample Test Formulation

	Kg	Protein		Lysine		Methionine		Cystine		ME* Calories
		%	kg	%	kg	%	kg	%	kg	
Rice polish	45	11	4.9	0.5	0.22	0.2	0.09	0.11	0.049	148,500
Sorghum	20	9	1.8	0.2	0.04	0.16	0.03	0.15	0.03	66,000
Cottonseed meal	15	45	6.6	1.8	0.27	0.66	0.10	0.90	0.135	30,030
Soybean meal	20	50	10.0	3.2	0.64	0.7	0.14	0.74	0.15	50,600
Total kg	100	23.2		1.17		0.36		0.364		295,130

* Total kilograms * calories per kilogram. To find metabolizable energy (ME) per pound, divide by 2.2.

This test ration has about 2,951 calories per kg, more than is needed, so more protein should be added.

$$\frac{\text{calorie requirement}}{\text{calorie requirement}} = \frac{2,750 \text{ 20\% protein requirement}}{2,951 \text{ 21.5\% adjusted protein level needed in this ration}}$$

The test ration actually has:

	Test Ration Content	Requirement
Protein	23.30 percent	21.5 percent (adjusted)
Lysine	1.17	1.2
Methionine + Cystine	0.17	0.8

The test ration is too high in protein quantity, but deficient in lysine and methionine + cystine. Some soybean meal might be substituted for some cottonseed meal, since the former has a higher lysine content. However, the ration still would be short on methionine. The total proportion of soybean meal might be increased, leaving the cottonseed meal as it is, but then the protein level would be uneconomically high.

However, fishmeal, which was not included in the first test ration because of its cost, is a good source of lysine and methionine. If some is substituted for soybean meal, protein quality needs will be met. Since the protein quantity in the first test ration already is too high, the proportion of sorghum should be increased (rice polish already is being used at the maximum level allowed).

Table 8-4: Sample of Second Test Formulation

	Kg	Protein		Lysine		Methionine		Cystine		ME* Calories
		%	kg	%	kg	%	kg	%	kg	
Rice polish	45	11	4.9	0.5	0.22	0.2	0.09	0.11	0.049	148,500
Sorghum	25	9	2.2	0.2	0.05	0.16	0.04	0.15	0.03	82,500
Cottonseed meal	15	44	6.6	1.8	0.27	0.66	0.10	0.90	0.135	30,030
Soybean meal	5	50	2.5	3.2	0.16	0.7	0.035	0.74	0.037	12,320
Fish meal	10	60	6	5.2	0.52	2	0.2	0.95	0.095	26,400
Total kg	100	22.2		1.22		0.465		0.353		299,750

The second test ration, with 1.22 percent lysine and 0.82 percent methionine + cystine, meets protein quality requirements. The ration's metabolizable energy is 2,997 calories per kilograms. To adjust protein level to that energy level:

$$\frac{\text{calorie requirement}}{\text{calorie requirement}} = \frac{2,750 \text{ 20\% protein requirement}}{2.9972: 0.8\% \text{ adjusted protein level needed in this ration}}$$

The protein content of the second test ration, 22.2 percent, is a little higher than the adjusted need, but that is a good safety margin.

Finally, checking arginine and tryptophan (Appendix E), we find that these amino acid requirements have been fulfilled. (The ration has 1.49 percent arginine, more than the 1.2 percent required, and 0.25 percent tryptophan, more than the 0.20 percent required.)

Ch 8: Feed and Nutrition

Now that the ration is balanced for energy, you can calculate calcium, phosphorus, and salt needs. Looking at the tables in Appendix E, you will find the ration has 0.79 percent calcium. The minimum is 1 percent, so add about 0.35 percent to be safe. The ration's available phosphorus content is about 0.28 percent. Therefore, add 0.4 percent to keep the calcium-to-phosphorus ratio in the recommended range (1.8:2.2 to 1). About 0.3 to 0.4 percent salt will be needed in this ration. Vitamin and other mineral needs will be provided by the commercial supplement.

You can also calculate the vitamin and mineral content of your feed mix, but this is difficult. It is easier and usually less expensive to use a commercial vitamin/mineral supplement available in almost all countries. Finally, if you are adding a coccidiostat or other substance, follow the instructions on the package.

Using a Protein Concentrate

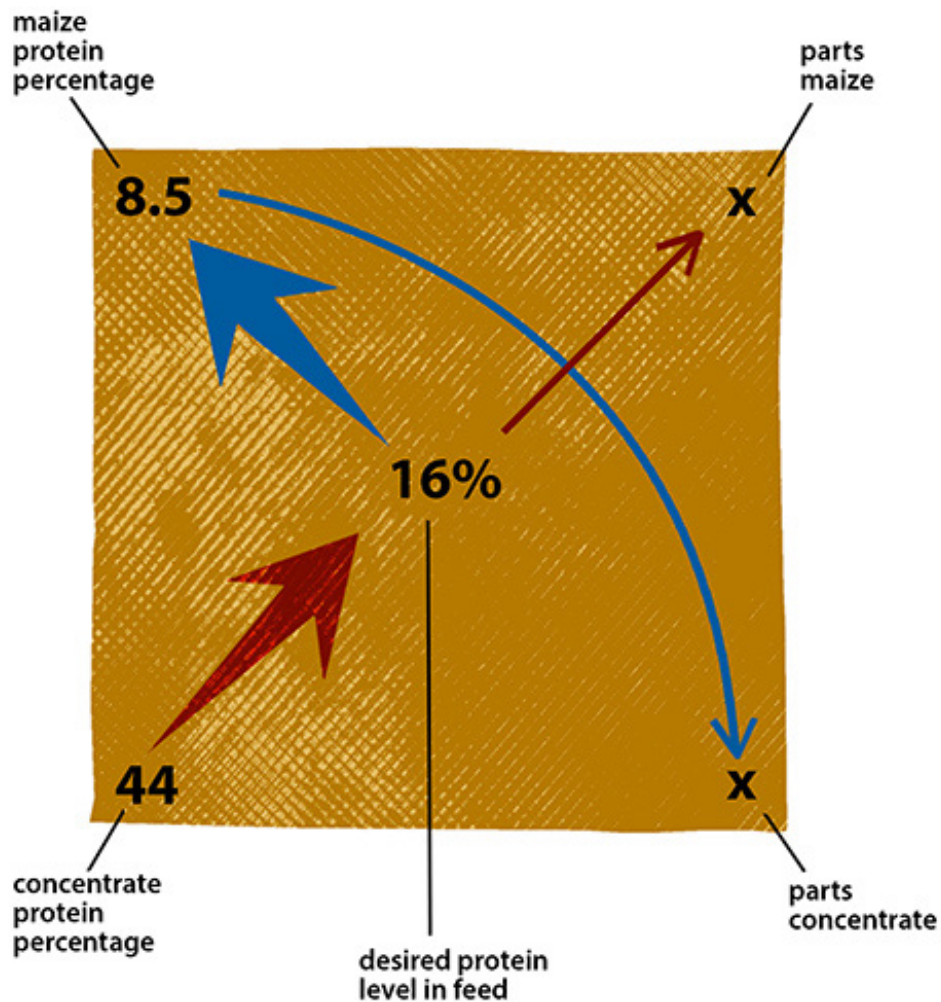
When commercial feeds are too expensive and mixing a complete ration is impractical, you can mix a commercial protein concentrate, which also contains vitamins with local grains or other carbohydrate sources, and perhaps some calcium. If available, the concentrate's formulation will help you balance the feed. When using a concentrate, it is necessary to know all of its ingredients and their specific nutrient makeup. Remember, vitamins deteriorate rapidly. If the concentrate is old or has been kept or transported improperly, the vitamins may have become useless.

Use the square method (see the figure below) to determine the relative proportions of protein concentrate and carbohydrate needed for particular types of chickens.

Example of Protein Ration

Use concentrate with 44 percent protein mixed with maize (8.5 percent protein) to obtain a 16 percent protein ration. In these calculations, the parts are by weight:

Figure. 8-2: Protein Ration



To find the right combinations, work diagonally, subtracting the smaller numbers from the larger:

$$16 - 8.5 = 7.5 \text{ parts concentrate}$$

$$44 - 16 = 28 \text{ parts maize}$$

To find the percentage of each in the feed, divide each number of parts by the total parts:
 $7.5/35.5 = 21.1$ percent concentrate
 $28/35.5 = 78.9$ percent maize.

Mixing Feeds

Feed must be mixed thoroughly so that all chickens receive a balanced ration. Coccidiostats, vitamin and mineral supplements, and other additives are used in such small amounts that they must be incorporated gradually. First, put in 1 to 2 kilograms (2.2 to 4.4 pounds) of an

Ch 8: Feed and Nutrition

ingredient and mix very well. Then, add the mixture to approximately 5 kilograms (11 pounds) of feed, mix well again, and add to the remaining feed before mixing it. Do not pre-mix the vitamin and mineral additive with the calcium, phosphorus, and salt—add them separately to the total feed.

There are several ways of mixing feed.

- **By hand:** You can mix 10 to 20 kilograms (22 to 44 pounds) of feed at a time in a large tub, or you can layer ingredients on a cement floor or a sheet of plywood or metal. Shovel the feed out from the center and then back, repeating the process until the feed is completely mixed. Repeat several times—remember: when shoveling to the center, always to allow the shovelful of feed to fall on the tip of the cone that is being created, which allows more even distribution of the nutrients.
- **Tumble mixer:** A clean oil drum mounted eccentrically on a stand makes an excellent manual mixer. If fitted with ball bearings, it can handle up to 70 kilograms (150 pounds).
- **Powered mixer:** If enough local farmers are mixing feed manually, they may want to join together to build or buy a powered mixer. Agricultural extension agents should have suggestions on designs or sources.

Figure 8-3: Tumble Mixer

Photo c/o creativecommons.org



Grinding Feed

Grain for chicken feed should be ground to a medium coarseness before being mixed with the other ingredients. If it is too coarse, the birds will pick it out and leave the rest. If it is too fine, it will sift through the rest to the bottom of the feeder. Very finely ground grain can become impacted in the birds' beaks, and birds will be reluctant to eat it.

Storing Feed

Mixed feed should be stored in a pest-proof and rodent-proof container raised off the floor. In hot weather, try not to mix and store more than a one-week supply at a time. Be especially careful when the feed has a high fat content: if it goes rancid, the flock may get sick or experience nutritional deficiencies. When buying pre-mixed feed, buy one with an antioxidant to help stop rancidity. Clean the container before putting in a new supply of feed.

Bags of feed or ingredients need a pest-tight room, where they should be stacked on slatted platforms raised at least 30 centimeters (1 foot) above the floor, so cats or dogs can patrol underneath.

Nutritional Deficiencies

The definite diagnosis of nutritional deficiencies in chickens requires experienced technicians and sophisticated pathology laboratory facilities. This is because:

- Deficiency symptoms are not noticed until severe.
- Symptoms of any specific nutrient deficiency are similar to symptoms of non-nutritional diseases or other deficiencies.
- Deficiency symptoms are not easily diagnosed, even in a laboratory. The fastest way to diagnose deficiency of amino acids is to calculate the amino acid content of the feed mix and, if possible, have the feed analyzed by a laboratory for confirmation.

Vitamin Deficiencies

Vitamin deficiencies in properly balanced rations are caused by loss of vitamin potency due to age or storage conditions. Symptoms include:

- Vitamin A: Decreased growth in chicks, reduced egg production in layers, along with reduced quality of eggs produced and paling of egg yolks. (Symptoms could be a result of many other causes.) Odorless substances in eyes and nasal passages. Staggering walk and nodules in the esophagus.
- Vitamin E: Deficiency causes poor growth, lack of coordination, stumbling, general muscular incoordination in chicks, usually beginning no earlier than 3 to 4 weeks. It is frequently most severe when accompanied by coccidiosis disease. Also causes death of chick embryo after 3 or 4 days of incubation.
- Riboflavin: Vitamin B2 deficiency causes poor growth, low hatchability, and curled toes (although some chicks have curled toes at hatching, which is probably a genetic problem and not a deficiency symptom). If many chicks develop curled toes after hatching, it could be a riboflavin deficiency.
- Vitamin D: Deficiency causes weak legs, soft or brittle bones, poor growth, weak eggshells, enlarged joints, and low hatchability.

There are many more vitamins and minerals that can cause poor growth, paralysis, low hatchability, increased mortality, and other problems. The real answer is to know what is in the feed being given to the chickens to avoid—as much as possible—the possibility of deficiencies.

Ch 8: Feed and Nutrition

In the case of country chickens and in locations where artificial vitamin supplements are not available, inclusion of the following foods in the diet will substantially reduce the chance of vitamin deficiencies:

- Vitamin A: Edible oils, grasses, yellow maize, alfalfa, clover, and most green leafy material.
- Thiamin: (Vitamin B1): Whole grain and grain byproducts, peanut meal, soybeans, grasses, and alfalfa.
- Riboflavin: Residues from fermentation processes, such as brewery residues, alfalfa, grasses, and some fishmeal.
- Pantothenic acid: Peanut meal, cereal grain brans, alfalfa, grasses, and fermentation residues.
- Pyrodoxine (B6): Rice bran, fish, wheat bran, rice byproducts, and alfalfa.
- Niacin: Rice bran, wheat, peanuts, meat, greens, and fermentation residues from corn distillers.
- Choline: Whole grains, cereal brands and polishings, peanut meal, and soybean meal.
- Biotin: Root tubers, alfalfa grasses, and whole grains.
- Cholic acid: Grasses, kale, alfalfa, wheat byproducts, and soybean meal.
- Ascorbic acid: Vitamin C deficiency has never been found in domestic chickens.
- Vitamin D3: Sunshine, fish oils and concentrates, and sun-cured grasses.
- Vitamin E: Found in all cereals and cereal brans, polishings, green foliage, and alfalfa meal.
- Vitamin K: Alfalfa, most green leafy vegetable matter, plant oils, meat scraps, and fishmeal.
- B12: Bean and peanut oil meals, dried cow manure, and various fermentation products.

Other Deficiencies

- Salt: Simply put enough salt in the ration. For country chickens, just add a pinch of salt to their feed mixture.
- Anti-gizzard erosion factor: Kale, grasses, alfalfa, wheat products, and soybean meal.
- Minerals: Other than calcium and phosphorus, deficiencies are not likely if a variety of ingredients are used in feed. In isolated cases, a mineral deficiency in the soil on which plants and animal ingredients are produced will also mean a deficiency in the mixed feed.

A final word on nutrition for those who don't have access to commercial feeds or traditional ingredients: you must keep your eyes open for ideas on alternative feed

ingredients. All types of insects and weeds are potential feed ingredients. Since little research has been done on these, you must use caution during early stages of feeding these. If you find that some local research has been done, use the results. Use common sense. Some seaweeds are high in protein and minerals, but must be washed with fresh water, dried, and fed only to a limited extent due to high salt content.

Points to Consider Before Using Nontraditional Ingredients

Do not consider using an ingredient that also serves as human food.

If energy feed (or protein feed) is not available, it will probably be easier and cheaper to import a complete feed.

It may be even cheaper to import eggs or chicken meat. Processing methods used will determine the energy and protein and vitamin content of various feed ingredients. For example, note the differences in the percent of protein content of soybean meal in Appendix D.

Remember that many plants are likely to contain toxins. Do not use these substances in large quantities.

Ch 9: Poultry Marketing and Finances

Before farmers enter the poultry field or expand current flocks, they must carefully consider what they will do with the meat and eggs their families don't eat. Forming a market plan means identifying where and when birds and eggs will be sold to receive the best prices. Suddenly putting large numbers of broilers up for sale in a small community may depress the price. Even small numbers of layers need advance planning—a flock of 100 may produce 1,000 dozen eggs in a year, even at the low production rate of 50 percent.

Other farmers' plans must also be considered. If you all expand their operations and have good years, prices almost inevitably will fall. Seasonal considerations also enter into market plans; in India, for instance, eggs are thought of as heating foods and are eaten in cool, rainy seasons.

Any farmer who wants to market poultry products must be certain they are fresh and of high quality so consumers continue to buy them. A reputation for good products is the farmer's greatest asset.

Many small-scale farmers are reluctant or unable to keep records, yet good records are a key to success. Without them, it is extremely difficult to spot problems and correct them. Wasteful practices can go unnoticed, and the farmer may operate at a loss without knowing it.

Marketing Country Chickens

If you are working with country chickens, consider them primarily as meat birds, although there will be some eggs for consumption or sale. The worksheet below assumes that the flock began with 10 chicks hatched and brooded by a hen.

Figure 9-1: Country Chicken Expenses and Income

Expenses
Night shelter:
Feed supplement:
Nest:
Worming medication:
Other (vaccinations, etc.):
Total expenses:
Income
About 60 eggs per year * 3–4 hens * price per egg (210 x):
Sale of 4–5 males at 15 weeks * average price (4.5 x):
Sale of 3–4 hens at 1½ years* average price (3.5 x):
Total income (less expenses, if any; Profit, (or loss))

Marketing Medium-Sized Broilers

The older meat birds are, the less weight they gain per unit of feed consumed. It is important to sell them as soon after 8 weeks of age as possible if they are of weight. The chart below lists average weights and feed consumption for a male meat bird (actual feed consumption and weight gain may vary widely, depending on quality of breed, feed, and care). Many farmers, especially with medium-sized flocks, may find it helpful to weigh feed before giving it to the flock and to weigh a sample of birds at least once a week.

Table 9-1: Feed Consumption—Male Broiler

Age in Weeks	Weight of Bird		Feed Consumption per Week		Added Weight per Unit of Feed per Week	Weight of Feed to Produce 1 Unit of Weight Gain*
	Kg	Lbs.	Kg	Lbs		
1	0.09	0.21	0.11	0.25		1.19
2	0.20	0.44	0.15	0.33	0.69	1.43
3	0.39	0.86	0.29	0.64	0.66	1.52
4	0.59	1.30	0.37	0.82	0.54	1.86
5	0.82	1.81	0.48	1.06	0.48	2.08
6	1.07	2.36	0.54	1.19	0.46	2.16
7	1.33	2.94	0.61	1.35	0.43	2.33
8	1.60	3.53	0.67	1.48	0.40	2.51
9	1.88	4.13	0.72	1.59	0.37	2.65
10	2.16	4.75	0.81	1.78	0.34	2.87
11	2.42	5.32	0.90	1.98	0.29	3.47
12	2.70	5.94	1.00	2.21	0.28	3.56
13	2.95	6.50	1.09	2.39	0.23	4.27
14	3.21	7.06	1.27	2.80	0.20	5.00

** Multiply this value by the price of feed per unit of weight. If the result is near the estimated price per unit of weight the birds can be sold for, continuing to feed them will be unprofitable. Figures in this chart are not adjusted for mortality.*

Rare is the small-scale farmer in the developing world who has access to refrigeration. Since meat spoils within a few hours unless kept cold, most broilers are sold live, either directly to consumers or through an established marketing system. Chickens can be transported to the market in well-ventilated baskets or wooden crates. Do not feed them on the day of sale, but be sure they receive plenty of water. If the trip to the market takes eight hours or more, stop and supply water to the birds or they may die. In hot weather, it is good to transport birds at night or during early morning hours.

Ch 9: Poultry Marketing and Finances

Most countries have set standards or commercial grades for meat birds, based on size, amount of meat per bird, skin color and condition, and other factors. A small-scale farmer usually needs to be concerned with grading, but should protect the farm's reputation by sending only good-quality birds to market, either by eating the others or selling them locally.

In the worksheet below, it is assumed that good management has kept mortality and feed consumption down, while producing healthy, heavy birds. Actual feed consumption and weight at sale may vary considerably.

Example of Return on Investment

Expenses
Feed:
Sold at 9 weeks:
398 kilograms (875 pounds) x _____ (feed price) = _____
Sold at 12 weeks:
636 kilograms (1,400 pounds) x _____ (feed price) = _____
Housing*: _____
Waterers, feeders, and other equipment*: _____
Heating and lighting: _____
Brooder and equipment*: _____
110-day-old chicks, plus transport: _____
Interest on financing, if any: _____
Contingency for emergencies (medicine, extra feed, etc.), add 10 percent: _____
Vaccinations: _____
Containers and transport to market: _____
Total expenses: _____
Income
100 broilers:
Sold at 9 weeks:
190 kilograms (375 pounds) x _____ (est. price) = _____
Sold at 12 weeks:
241 kilograms (530 pounds) x _____ (est. price) = _____
Value of manure sold or used: _____
Total income: _____
Less total expenses: _____
Profit (or loss): _____

**If you think housing and equipment will last three years, use 10 percent of these expenses for each 14-week cycle (preparation, growth, and sale). If they will last four years, use 6 percent, etc.*

Weighing Chickens

Keeping records of the weight of a flock and the weight of feed it eats helps the farmer in several ways. With this information, losses in body weight or decreases in feed consumption—two major signs of disease—can be spotted. In addition, the farmer can more easily see when meat birds have reached uneconomical rates of feed consumption.

The easiest way to weigh a live chicken is to place it headfirst in a sheet-metal cone. Adjust the scale for the weight of the cone, or subtract its weight from the scale reading.

It is not necessary to weigh all the chickens. A sample of 5 or 10 percent of what appear to be average-size birds will do.

Storing Eggs for Market

Before marketing, eggs must be kept as cool as possible, ideally at 4.4 to 12.8°C (40 to 50°F). In hot weather this often isn't possible, and the farmer should send the eggs to market at least every third day. Do not leave eggs in direct sunshine, even for a few minutes.

One way to store eggs temporarily is to bury a clay pot up to its neck in a shaded area. Water the ground around the pot, but don't leave puddles. Put straw or a mat in the pot to cushion the eggs and keep them above any water in the bottom of the pot. Put the eggs in the pot as soon as they are collected, and cover the pot with a cloth and damp straw. The inside of the pot probably will be about 5.5°C (10°F) cooler than outside.

Eggs absorb strong odors quickly; don't store them near onions, kerosene, or other substances with strong odor, or in mildewed areas.

Cleaning Eggs

Eggs soiled by droppings or by the contents of leaking or broken eggs not only spoil faster than clean ones, they also fetch lower prices. An egg has a natural protective coating that resists the entrance of bacteria and retains moisture inside. Washing eggs with water removes this protection, so make washing eggs a last resort—and eat washed eggs as soon as possible. A preferred method of cleaning eggs is rubbing them lightly with fine sandpaper, emery cloth, or steel wool.

Figure 9-2: Cone Scale

Photo c/o creativecommons.org



Ch 9: Poultry Marketing and Finances

Egg Grading

The main idea in grading eggs is to sort them so only good quality eggs are sent to market, and that they receive the best possible prices. The simplest and most important method of sorting is to divide the eggs into three categories: cracked, dirty and clean. The cracked eggs are eaten by the family or sold locally for immediate consumption. The dirty ones are cleaned and sold locally for consumption within three days, while the clean eggs are sent quickly to the major marketing outlet.

If people pay a premium for eggs of certain colors or sizes, the farmer should sort for those qualities. Most countries have established egg size standards. If none exist in your area, people may want to set their own.

Table 9-2: Suggested Egg Size Categories

	Grams	Ounces
Jumbo	64 and up	2¾ and up
Extra Large	57–63	2¼ – 2½
Large	50–56	2 – 2¼
Medium	43–49	1½ – 1¾
Small	35–42	1½ or less

People in a few areas prefer fertile eggs. If you are in such an area, you should allow for this by keeping roosters with the layers, but for the most part, all eggs sold should not be fertilized. These will stay edible much longer in warm weather than will fertile ones.

Storing Eggs for Home Consumption

A clean, unwashed, and uncracked egg kept in the shade should remain edible for up to two weeks. Store only good eggs—use a candler, if possible, to determine their quality. The following are ways of storing them longer without refrigeration:

- **Oil:** A thin film of oil on an egg fills its pores and reduces evaporation and oxidation of the contents. With a wire basket, dip the eggs into slightly heated oil, about 11°C (20°F) warmer than the eggs. A light mineral oil is best, but almost any cooking oil (such as coconut) that doesn't turn rancid rapidly will do. If you re-use the oil, filter it and heat it to 116°C (240°F) to sterilize it. Oiled eggs will last for three weeks or longer if kept under 10°C (55°F)
- **Clay pot:** Place eggs in clay pot buried in the ground. Cover the pot tightly, and be sure no water gets into the pot.

Ch 9: Poultry Marketing and Finances

- **Water glass:** For 100 eggs, use a 25 liter (6.5 gallon) pot or jar. Mix 5.25 liters (5 quarts) of previously boiled, cool water with 0.5 liter (0.5 quart) of water glass (sodium silicate). Place the eggs in the pot and cover them with the water-glass solution. Cover the pot and keep it in a cool, shaded place. The eggs should keep for one to six months.
- **Lime water:** Mix 2.3 kilograms (5 pounds) of quicklime (finely powdered lime) in 6 liters (6.3 quarts) of boiled and cooled water and allow to stand overnight so the lime settles. Place eggs and the clear lime solution in a pot, cover, and keep cool. The eggs should last more than a month.
- **Packaging eggs:** With a medium-sized laying flock, it may be worthwhile to investigate the possibility of purchasing special cardboard egg containers; 100 layers may produce 2,000 eggs or more a month. Place the eggs, small end pointed downward, in the containers to reduce breakage.

Size of Flock

To take advantage of economies of scale, this manual recommends that a laying flock contain at least 50 to 100 birds. Many costs, such as housing and equipment, will be about the same as for smaller flocks, as will the time needed to care for them. The following worksheet assumes good stock, feed, and care.

Table 9-3: Expenses and Income for 100 Layers

Expenses
Feed to 24 weeks
<i>White-egg breeds:</i>
1,136 kilograms (2,500 pounds) x _____ (feed price) = _____
<i>Brown-egg breeds:</i>
1,418 kilograms (3,120 pounds) x _____ (feed price) = _____
Housing ¹ : _____
Feeders, waterers, other equipment ¹ : _____
Litter: _____
Heating and lighting, if any: _____
Brooder equipment: _____
Brooder fuel: _____
115-day-old chicks ² : _____
Transport of chicks: _____
Interest on financing: _____
Contingency for emergencies (medicine, etc.), add 10 percent: _____
Vaccine: _____
Total initial investment: _____

Ch 9: Poultry Marketing and Finances

Production Cycle: 100 Layers (adjusted for 1 percent per month mortality)
Feed, for 1 year <i>White-egg breeds:</i> 4,150 kilograms (9,125 pounds) x _____ (feed price) = _____ <i>Brown-egg breeds:</i> 5,000 kilograms (11,000 pounds) x _____ (feed price) = _____ Housing: _____ Feeders, waterers, other equipment ¹ : _____ Roosts: _____ Additional litter: _____ Cages ¹ : _____ Nesting boxes: _____ Heating and lighting, if any: _____ Collection and storage (baskets, pots, etc.) ¹ : _____ Egg containers, if used: _____ Transport of eggs and hens to market: _____ Hired labor: _____ Interest on financing: _____ Miscellaneous (worming medication, etc.), add 1 percent: _____ Vaccinations: _____ Total production expenses: _____
Income
Sale of eggs <i>White-egg breeds :</i> 24,000 eggs x _____ (feed price) = _____ <i>Brown-egg breeds:</i> 23,000 eggs x _____ (feed price) = _____ Sale or use of manure as fertilizer: _____ Total income: _____ Less initial and production expenses: _____ Profit, (or loss): _____

1. Prorate expenses over expected life of housing equipment.

2. If sexed chicks aren't available, buy about 225 chicks, adjust expenses on equipment and feed, and adjust income for sale of 100 broilers.

Records

Records should be kept to help analyze the operation and pinpoint problems. To be useful, records should be uncomplicated and accurately kept. A farmer should keep track of all expenses (looking for ways to cut them) and production (seeking methods to increase it). A

Ch 9: Poultry Marketing and Finances

good way to record egg production is to post a form similar to the one in Table 9-4 inside the chicken house, with a pencil on a string nearby. A full year of production can be recorded on such a form.

Table 9-4: Egg Production Record

Farmer:

Hatch Date:

Date Housed:

Breed Source:

Date	1	2	3	4	5	6	7	8	9	10	11	12	13	14	15	16	17	18	19	20	
No. Eggs																					
a.m.																					
a.m.																					
p.m.																					
p.m.																					
Total																					
Birds																					
Removed																					
Pounds Mash																					
Other Feeds																					
Date	21	22	23	24	25	26	27	28	29	30	31	Total for Month:		No. of Birds:							
a.m.												First of Month									
a.m.												Sold:									
p.m.												TOTAL									
p.m.												End of Month:									
Total																					
Birds																					
Removed																					
Pounds Mash																					
Other Feeds																					

Ch 9: Poultry Marketing and Finances

If you work in poultry extension, you will want more information on expenses and production, including:

- Breed, source, hatching date, and cost
- Number of birds at the start, and current number
- Type of feed, daily or weekly consumption, and cost
- Cost of housing and equipment
- Feed supplement used, if any, and cost
- Type of medicine or vaccine administered and cost
- Disease or parasite problems present
- Type of litter used, if any, and cost
- Average weekly egg production
- Weather (hot, cold, sudden change)
- Number of birds culled and reasons
- Receipts from sale of eggs and meat
- Family consumption of eggs and meat

Increasing Poultry Profits

Cutting costs, increasing production, responding to market conditions, and price fluctuations all can increase profits. Concentrate on:

- Feed wastage: Well-designed, durable feeders are worth the expense since they reduce wastage. Fill them one-third full for minimum wastage.
- Space utilization: Try for a full but not crowded house, to keep per-bird house expense as low as possible. An experienced farmer can raise a mixed-sex flock to 10 weeks, filling the house, selling the males as broilers, letting the females grow to laying size, and filling the house again.
- Maintaining production: A 2 kilogram (4.4 pound) hen eats about 27 kilograms (60 pounds) of feed a year just to maintain her weight. She uses about another 6.8 kilograms (15 pounds) to produce her first 100 eggs, about 5.9 kilograms (13 pounds) for the second 100, and 6.4 kilograms (14 pounds) for the third 100. Good management and culling of non-layers are essential for profits.
- Feed quality: An inexpensive feed that is not well-balanced does not save money. It reduces production.
- Breed source: Breeds that produce best usually cost more, but make up for it by increasing sales.

Ch 9: Poultry Marketing and Finances

- Broken or soiled eggs: Good management and frequent collection will minimize losses from broken or soiled eggs.
- Deep litter: Chickens lay up to 5 percent more eggs when kept on deep litter, in addition to producing more valuable fertilizer.
- Timing: Try to bring eggs and meat to market when prices will be highest.

Sources of Finance

Many small-scale farmers don't have the cash to start raising medium-sized poultry flocks, and loans are difficult to get because poultry raising is often viewed as a high-risk business. It is true that failures may exceed successes with inexperienced farmers, but studies have shown that small-scale farmers have a very good record of repaying loans. Drawing up a specific management and repayment schedule may help overcome lender reluctance. Lenders also may avoid making loans to small-scale farmers for fear that they will misuse the money. One way around this is to have purchases for the flock made through the lender. Some funding sources are:

- Government agencies: Most developing countries have agricultural loan programs channeled through administrative or agricultural extension networks.
- Private lenders: Banks, traditional local moneylenders, and marketing "middlemen" are potential private lenders. Some may be better than others, of course, and all possible sources should be investigated thoroughly.
- International agencies: The World Bank, Oxfam, USAID, CARE, UNICEF, and others sponsor rural development in some countries. Such programs are often administered by the host government.
- Others: Cooperatives, credit unions, women's groups, chick suppliers, feed manufacturers, and others may be good credit sources.

A good loan application would include, but of course is not limited to, the following information:

- A description of the current operation and past successes
- A current balance sheet
- A projected income and expense statement
- A chronological management plan
- A schedule of visits by extension personnel
- A market plan, including names of potential buyers with allowances for losses during transport
- A repayment plan: 10 to 12 weeks later for meat breeds, beginning in 7 months for layers

Ch 9: Poultry Marketing and Finances

Poultry and Egg Cooperatives

Joining or helping to create a cooperative can reduce a farmer's costs and increase income if the co-op is well run. The formation of a co-op usually is regulated by the government, which also monitors its operation.

Co-ops can cut costs through bulk purchases of feed, chicks, and equipment. They may also buy mixers and prepare their own feed, breed and rear chicks to distribute to members, and provide extension advice. In addition, they may provide low-cost financing. On the marketing side, co-ops can cut transport costs by pooling shipments, inspect and grade products, negotiate large-scale contracts, and purchase refrigeration equipment to store products during low-price seasons. Farmers may also profit by helping finance the co-op, working for it, and sharing experience with other members.

Good agricultural extension is a two-way system. Scientists and administrators provide research results and suggestions to the farmer, while the farmer offers questions and reports of actual results. The agricultural extension agent is the person in the middle, channeling the flow of information in both directions. In addition, the extension agent acts as a liaison with different farmers, learns about their good ideas, and shares this information with others.

Contact Poultry Farmers

Depending on local circumstances, you can apply this system, formally or informally, to your situation. As you begin forming a good picture of local poultry practices and the most obvious production gaps, you can consult with others and identify contact farmers.

They may be inexperienced with poultry. While the farmer's potential risk and your responsibilities may be greater, you will not have to overcome traditional but inefficient management practices.

With farmers who are experienced with poultry, you should know their history and the current condition of their flocks, and review with them how they can improve. If, for example, the farmer has lost 1 to 2 percent of the flock per month, there may have been a feed, disease, or other problem, but the flock may have potential. If mortality has been much higher, the flock may have less potential for recovery, especially as layers. If there are only a few runts (chicks distinctly smaller than their hatching mates) in the flock, the farmer can remove the runts and work with the rest of the flock. If 20 percent or more are runts, the flock probably is not a good one to work with.

In selecting contact farmers, it may be helpful to review with them from a form similar to the Farmer Specific Assessment Criteria sheet in Appendix C.

Timing of Suggestions

Once you have identified a contact farmer or farmers and arrived at a mutually agreed-upon general plan, it is important to discuss specific management techniques to receive attention during the next two weeks. If a farmer expects a shipment of chicks in a week, talk about brooding, not egg storage. If the flock shows signs of severe coccidiosis infestation, talk about treatment, not about improved feeds. If local custom permits, try to involve all family members who actually work with the flock.

Ch 10: Poultry Extension

Training

In many countries, veterinarians and laboratories are more concerned with other livestock than poultry. Even poultry specialists may have so many other duties that they have very little time for fieldwork. A good poultry extensionist can help take their place in the field by consulting with them and calling for their services only when most needed.

For instance, extensionists in an area may agree that coccidiosis is a severe local problem that should be emphasized in the coming weeks. That is the time for them to invite or go to an expert for a short course on treatment of the disease. In the next two weeks, the extensionists work with farmers on the coccidiosis problem, thus thoroughly learning about practical applications of the theory. The farmers should see immediate improvement, and the specialists can tackle other areas or problems.

If there are no other poultry extensionists in your area and information sources are far away, you can create your own in-service training program, reading as much as you can, writing to people who may have answers to local problems, and visiting successful poultry operations. If you have no previous poultry experience, you should seek out places where you can gain actual experience in:

- Recognizing sick chickens
- Coccidiosis and other disease control
- Culling of layers
- Performing a postmortem examination
- Debeaking
- Forced molting, when appropriate

Special Poultry Projects

If your primary assignment is something other than poultry extension, you still can be helpful in increasing local interest and involvement in poultry production.

Teachers may have much to offer their students and the community. Biology teachers can use old hens for dissection studies, explaining how the various organs work and how embryos develop within the eggs. If a thermostat is available, the class can make and use an incubator and a candler, obtain fertile eggs (perhaps from the students' family flocks), keep records of temperatures and turning, and, if accepted by local custom, open an egg or two every few days to determine stages of embryo growth. Math and economics teachers can use poultry examples in their exercises with students. Home economics and nutrition agents and teachers can explain and demonstrate ways of preparing eggs and poultry meat. Chemistry teachers

can perform simple analysis of feed ingredients with their students if a laboratory is available. The possibilities are almost limitless.

A school flock of broilers could be an excellent 8- to 12-week project. If properly managed, the students should be impressed by the birds' growth and carry some ideas back to their parents. The project could be culminated by a school/community dinner, with students taking chickens home or selling the birds in the market.

A variation of the school flock project would be to conduct nutrition studies, having students mix different rations and feeding them to separate small groups of birds, beginning with day-old chicks. The effects of different qualities of rations should become evident in two or three weeks. It may even be possible to obtain some started pullets and conduct studies in egg production, either to supplement the students' diets or to market the eggs.

Those working on small business development in poultry-raising areas may find that the situation is ripe for developing or assisting a poultry or egg cooperative, or helping groups of farmers with their accounting and marketing problems.

Participants, such as Peace Corps Volunteers with training in chemistry and nutrition, can help analyze feeds being used and devise low-cost improvements.

Anyone with ingenuity, organizational ability, and perseverance—no matter what his or her background—can become involved in projects such as:

- **Market promotion:** To help deal with seasonal surpluses. For example, a Volunteer in India helped a youth club open a successful shop selling omelets and cold drinks during the hot season, when many people otherwise could not eat eggs.
- **Pest eradication:** To improve conditions for everyone, not just poultry farmers. Study local traditions before you start such a project.
- **Grain storage:** This also could benefit everyone, not just poultry farmers.
- **Feed production:** Helping grow, process grain, and other agricultural products while keeping in mind the use of byproducts as chicken feed.
- **Use of manure:** In some areas, chicken manure is wasted. Help compost it and use it on a demonstration garden, build a model methane gas generator, or use the manure to fertilize fishponds.
- **Extension publications:** Concise publications in the local language that explain how farmers can improve the management areas under their control can be very helpful. Feed suppliers, breeding companies, or others will often help pay for such publications, either through complete sponsorship or by advertising in them.

Ch 10: Poultry Extension

- **Model equipment:** Small-scale cardboard or paper models of houses, feeders, waterers, and other equipment can help you or others in the design and construction of the actual items, and serve as excellent visual aids for extension efforts.

Information needed for many of the above projects is contained in Peace Corps publications, available at your local Peace Corps office or through the Knowledge and Learning Unit at Peace Corps Headquarters. You can order publications from your Peace Corps librarian or check with your country director. Most of these publications are also available online.

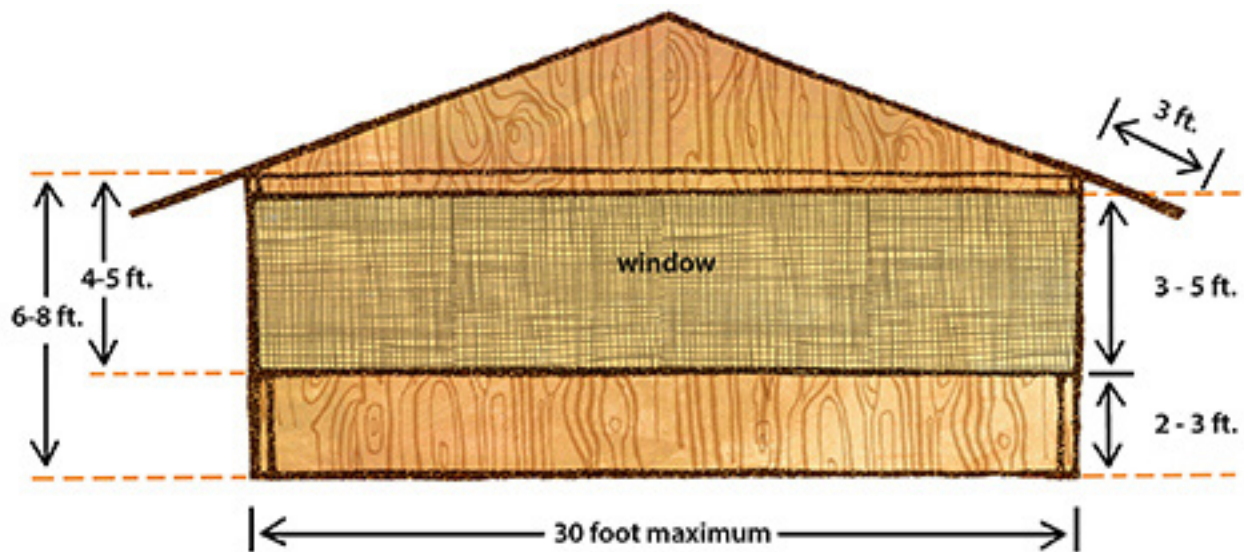
You can help small-scale farmers benefit from this information and provide feedback on the accuracy and usefulness of materials. Sometimes the most valuable contribution a Peace Corps Volunteer can make is to make farmers aware of the broad network of resources available to them.

Appendix A: Housing Designs

It is unlikely that any two farmers will have night shelters or any other poultry structures that look exactly alike.

Building construction should ensure that there is sufficient overhang to prevent rain from entering the building even in windy weather, but the overhang must not interfere too much with ventilation. A 3-foot overhang is usually about right for poultry houses, where the bottom of the window is not more than 4 or 5 feet below the point where the roof meets the wall. In hot climates, the overhang helps shade the interior of the building. The window can go right up to the point where the wall and the roof meet if the local climate is not very windy (15 to 20 miles per hour). The total height will be determined by the width of the building. The wider the building, the higher the wall must be to allow increased ventilation. A building 15 to 20 feet wide should have windows at least 3 feet high for most locations. A building 25 to 30 feet wide should have windows 5 feet high. Windows should extend the full length of the poultry house.

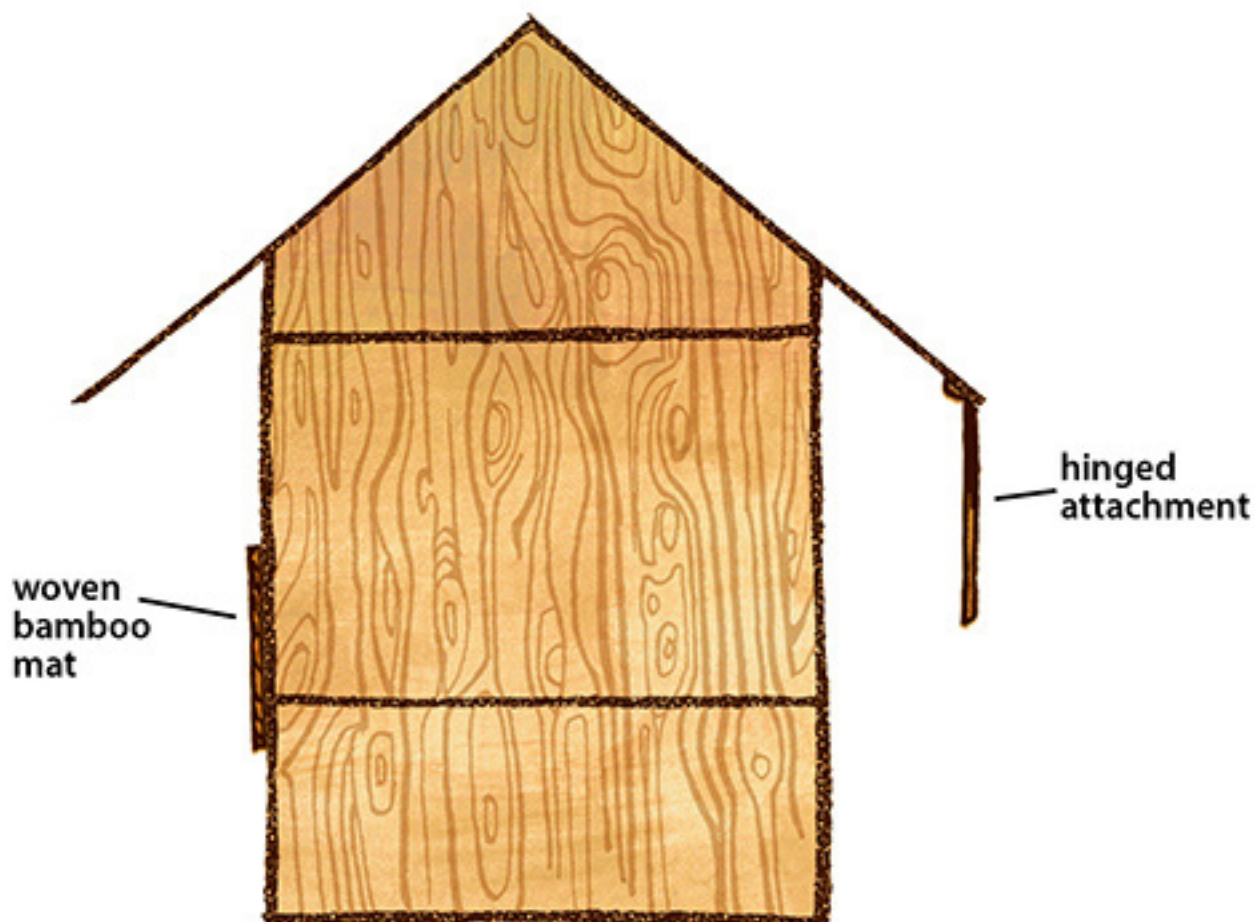
Figure A-1.:Housing Design



To protect against severe weather, especially high winds accompanied by rain, buildings may have a hinged attachment that can be swung down. It can be a permanent part of the building or a weighted bamboo mat attached to the roof structure. An alternative is a woven mat tied securely to the lower part of the window area.

Appendix A: Housing Designs

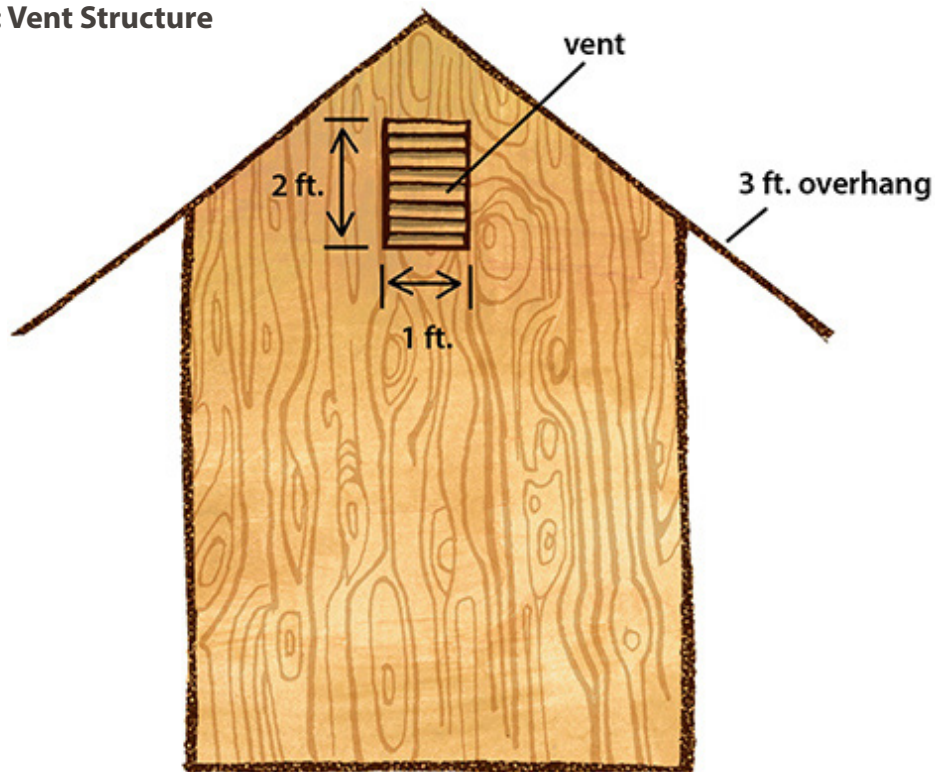
Figure A-2: Hinged Attachment



These fixtures can also be used to permanently correct improperly designed buildings in areas where there are consistently strong winds.

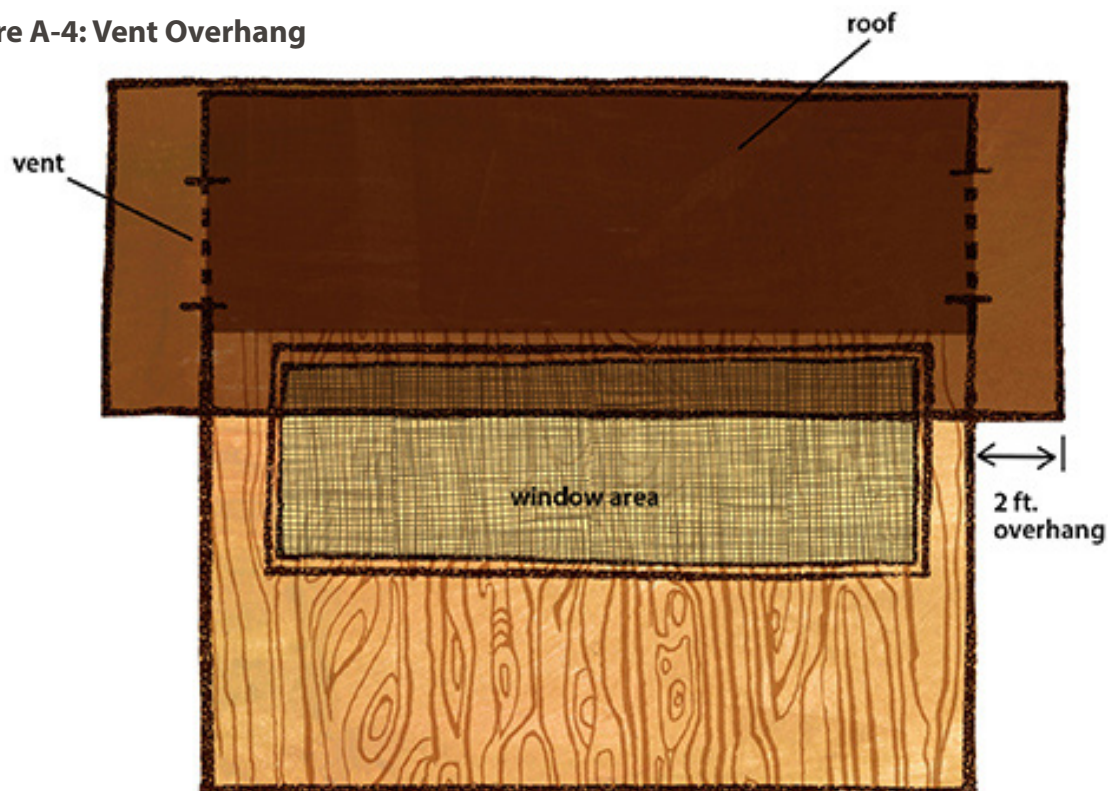
End of building: To avoid rain's entering the building, it is best to have the entire end closed, except for a screened vent just under the roof gable.

Figure A-3: Vent Structure



The vents allow hot air to rise and escape and should be about 1 foot wide and 2 feet high. The overhang over the vents must be adequate to keep rain from entering.

Figure A-4: Vent Overhang

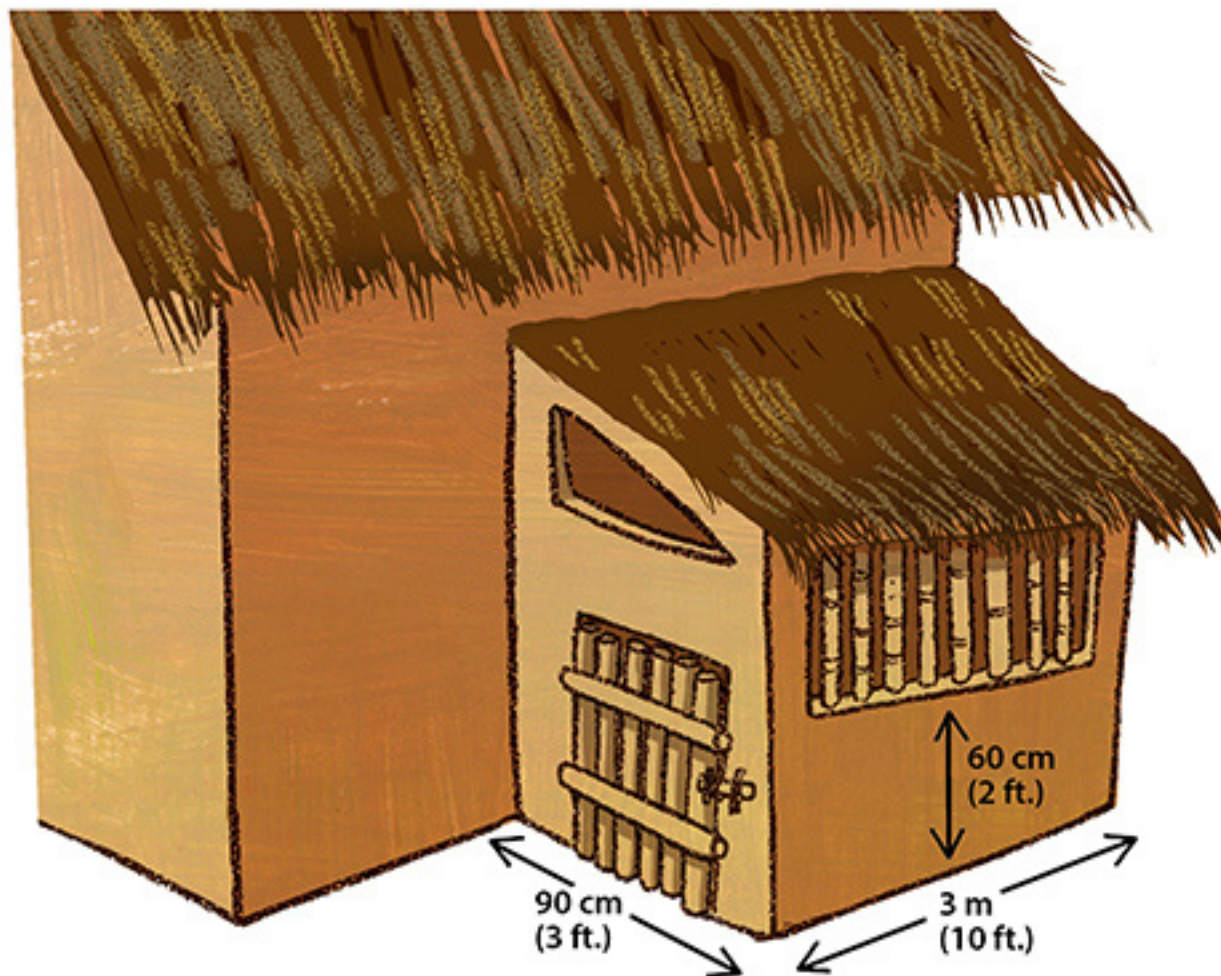


Appendix A: Housing Designs

Night Shelter

A night shelter is for 20 country chickens attached to a family house or other structure. Allow about 933 square centimeters (1 square foot) per bird. Use deep litter or keep floor clean. In areas with heavy rains, allow a generous roof overhang.

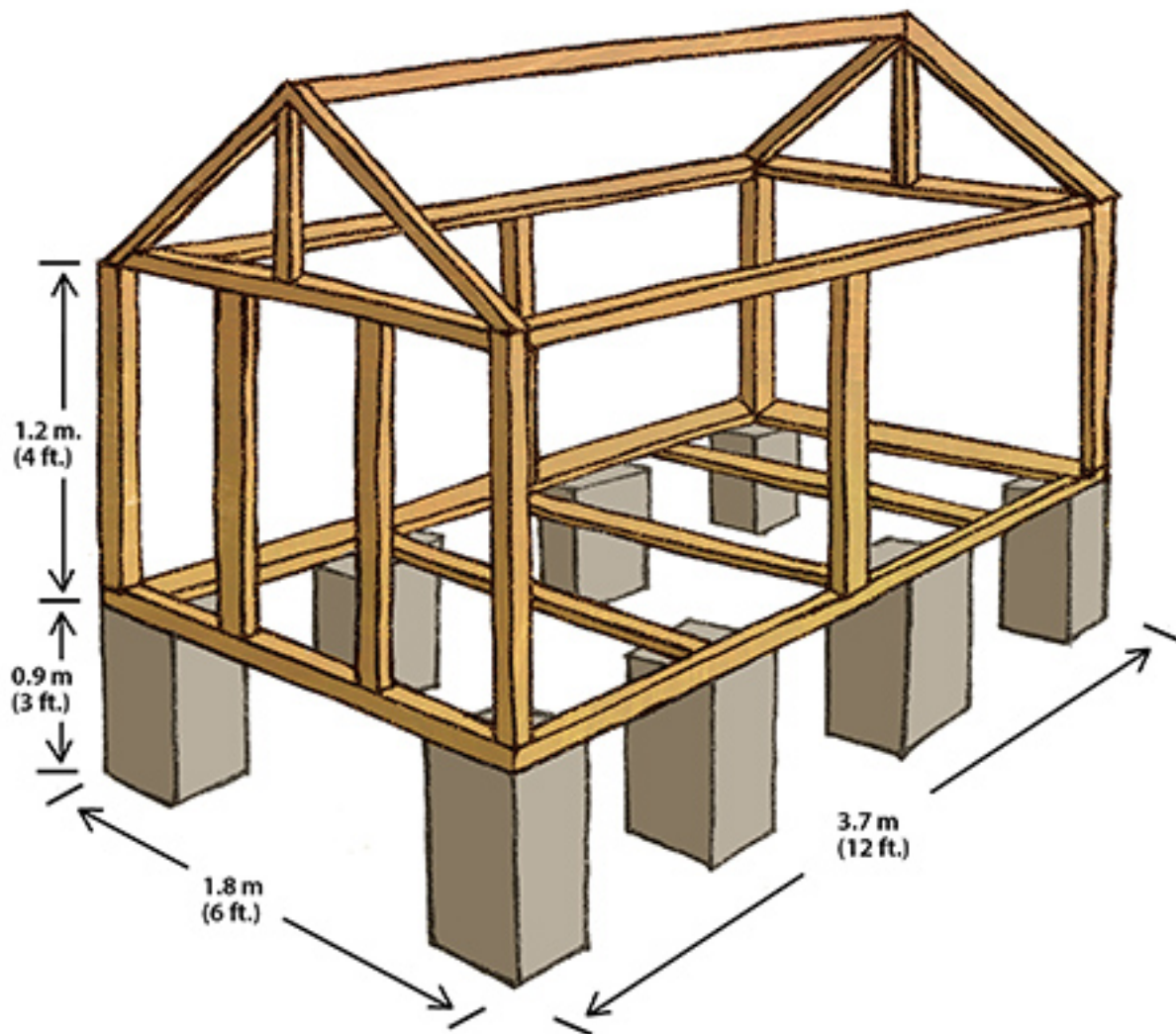
Figure A-5: Night Shelter



Raised-Floor House

The interior structure of a raised-floor house is for 59 broilers or 25 layers. It is for use in hot, humid climates. Cover the floor with bamboo or wooden slats and enclose the house with wire mesh or wooden or bamboo slats.

Figure A-6: Raised-Floor House

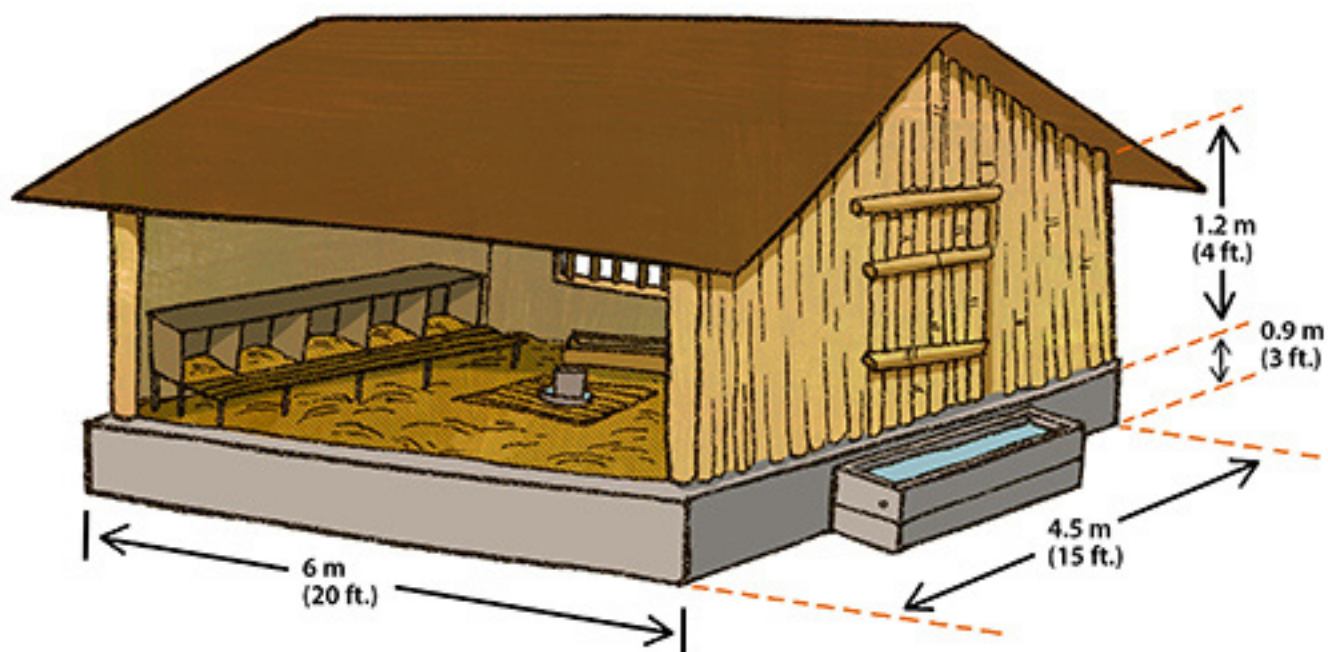


Appendix A: Housing Designs

Deep-Litter House

Below is a cut-away view of a deep-litter house for warm climates. Enclose in wire mesh or wooden or bamboo slats. This house can hold 200 broilers or 100 layers.

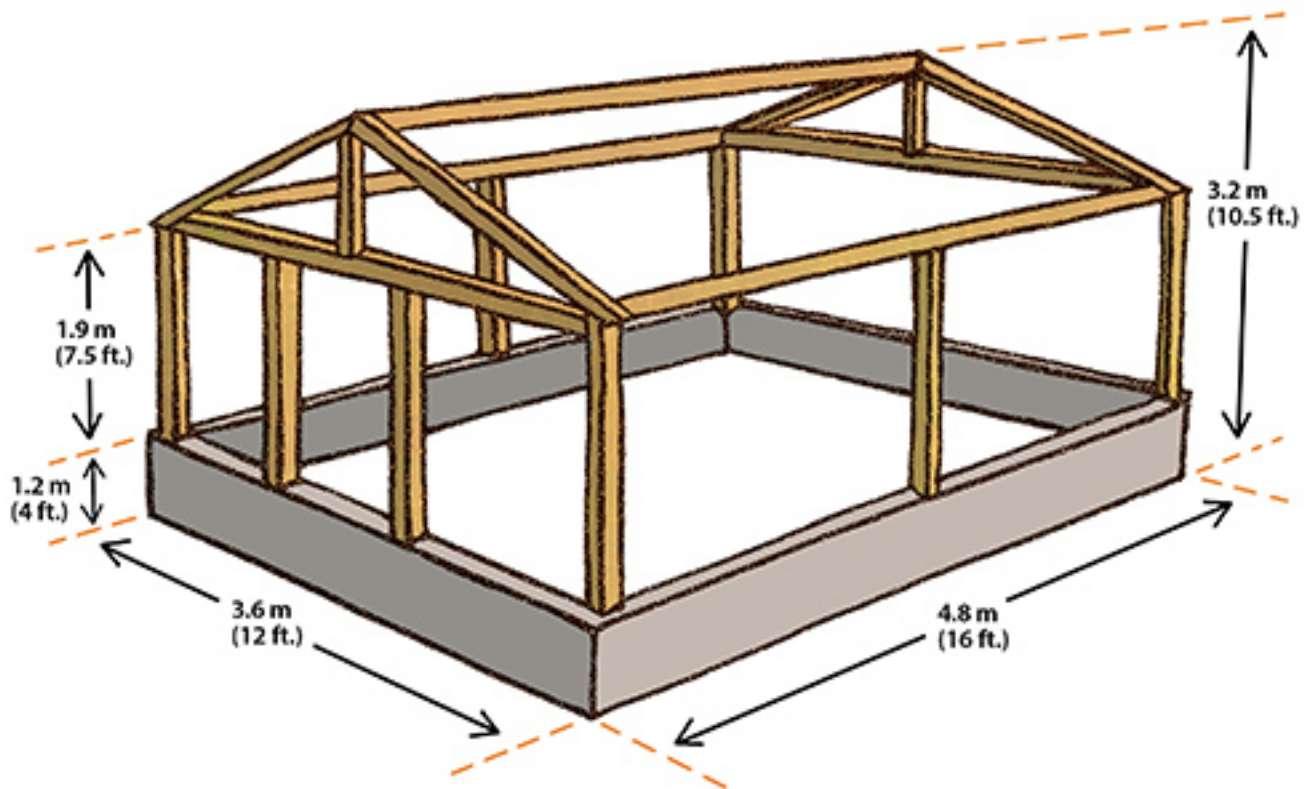
Figure A-7: Deep-Litter House



Pole-Type House

The pole-type house is for 50 to 75 layers. The roof framing can be assembled in two sections raised into position and secured to the poles. Sheeting may be made of plywood or any available local substitute. Leave small slotted openings between the rafters at the front and rear eaves for ventilation. Cover windows with plastic, mats, burlap, or other materials during cold weather.

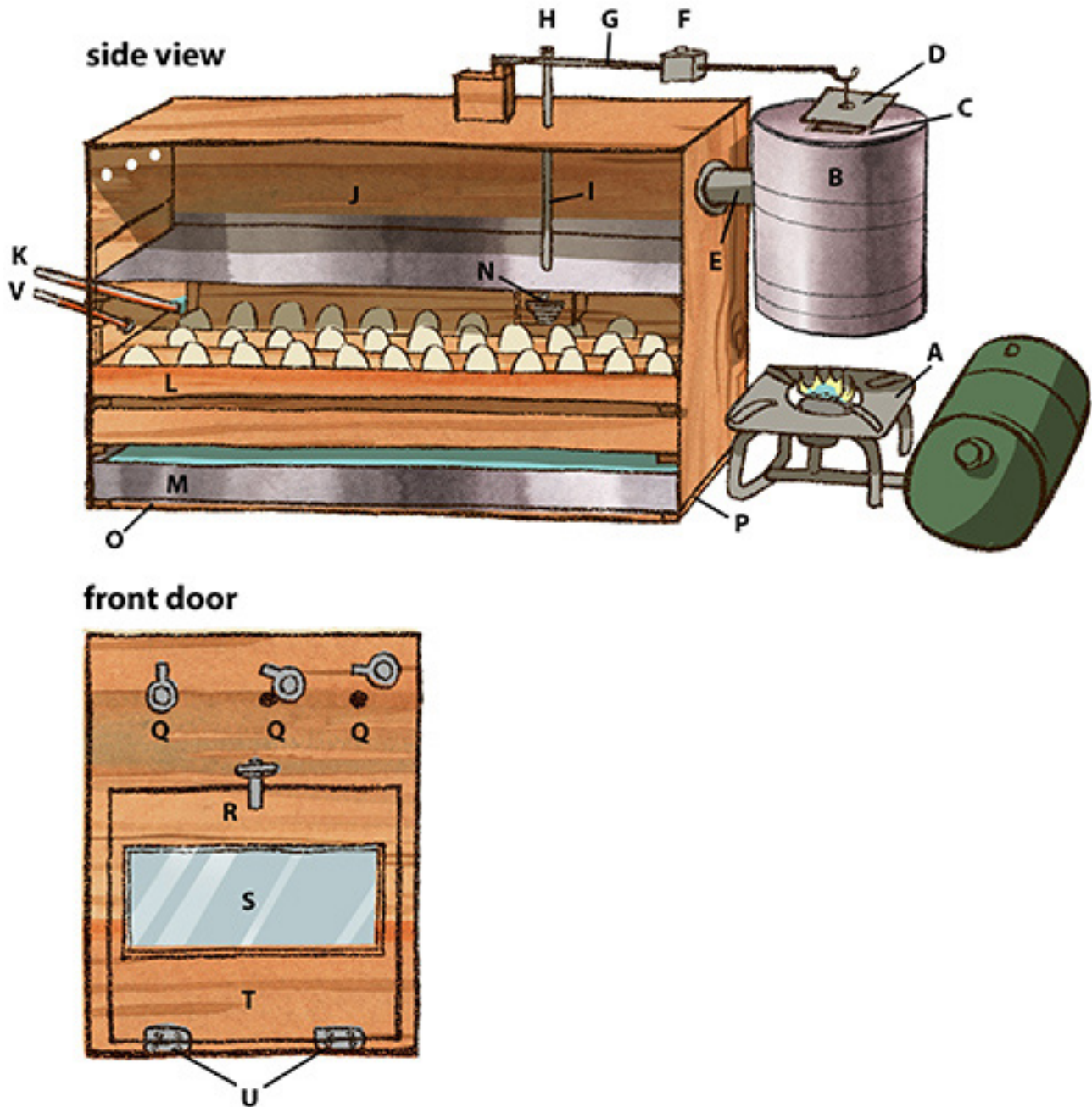
Figure A-8: Pole-Type House



Appendix A: Housing Designs

Kerosene-Heated Incubator

Figure A-9: Kerosene-Heated Incubator



Appendix A: Housing Designs

Key

- A. Kerosene lamp, 200-watt light bulb, or other heat source
- B. Tin can: about 30 centimeters (12 inches) in diameter
- C. Exhaust: about 10 centimeters (4 inches) in diameter
- D. Damper: fitted snugly over the exhaust hole
- E. Heat inlet: about 7.5 centimeters (3 inches) in diameter
- F. Weight: Slide toward heat source to increase internal temperature; away to decrease
- G. Hinged arm: suspends and moves damper
- H. Set screw joins arm and rod together from thermostat
- I. Rod: connects thermostat and arm
- J. Chamber: sheet metal bottom, sealed and vented
- K. Dry bulb thermometer: accurate in a 35°C (95°F) to 40.5°C (105°F) range; thermometer bulb about 1.25 centimeters (½ inch) above eggs
- L. Egg tray: 60x60 centimeters (2x2 feet) for 100 eggs; 43x43 centimeters (17x17 inches) for 50 eggs; made of sheet metal or wood with a fine wire mesh bottom
- M. Water pan: sheet metal
- N. Thermostat: liquid or gas filled disc that expands with rising heat and contracts with falling heat; usually purchased
- O. Insulation: optional, depending on cabinet materials
- P. Cabinet: of soft wood (for insulation value) or two sheets of veneer or metal filled with sawdust, rice hulls, or other insulation
- Q. Vents: in front and back of cabinet, help adjust internal temperature and humidity
- R. Latch: holds door closed
- S. Window of glass: optional
- T. Door: wood or insulated sheet metal
- U. Door hinges
- V. Wet bulb thermometer: to measure humidity

Appendix B: Other Poultry

Ducks

Domestic ducks are often much easier to care for than chickens: they are hardy, disease-resistant foragers. There are three principal breeds: Khaki Campbell for eggs (lays 300 to 350 per year for three or four years under good management), and Aylesbury or White Pekin for meat, reaching 3 kilograms (7 pounds) or more at 7 weeks of age.

Muscovy ducks, the most common birds in villages, are larger than true ducks (Muscovies are sometimes classified with geese). Older Muscovies have enlarged, unfeathered skin on their faces. Mallards (the males have green heads), typically found wild, are also raised, but are smaller than domestic breeds.

Due to the strong taste of duck eggs, local acceptance varies widely from area to area. Duck eggs are larger than chicken eggs and spoil more quickly (in about a week). Muscovies seldom produce more than 60 to 90 eggs per year, depending on their age.

Ducks can be raised using the same equipment as chickens. Waterers should be deep enough for them to submerge their heads (the same is true for geese). Ducks are very messy; great care should be taken if they are raised on deep litter. Ducks are more resistant to coccidiosis than chickens and tolerant to cholera. (Cholera can be transmitted by ducks to chickens, however.)

Farmers usually keep one drake (male) for every two females. Duck eggs take 28 days to hatch; although Muscovy eggs take 35. Opinion is divided on whether ducks make good mothers (Muscovies do), so many people use broody hens to raise ducklings. As with broody hens hatching chicks, keep water near the hen.

If you use a brooder for ducklings, set it at 32.2°C (90°F) for the first week, and reduce by 2.8°C (5°F) each following week. During their first four weeks, ducklings should be kept warm and dry. In their early weeks, the ideal feed is starter pellets, although moistened mash, whole grain, and/or fresh greens will do.

Once outside, ducks do well on grasses and insects and will keep a mature garden free of snails and slugs. Don't let them in a growing garden—they will devour it. They need no supplemental feed, but a few handfuls of grain scattered or placed in a trough in the evening will keep them closer to the house. When catching ducks or Muscovies, hold them by the wings, not the legs. Ducks can be held by the neck without any discomfort to them.

Ducks are difficult to pluck, but their feathers often are valuable; melted wax helps in plucking (see Geese, below).

Geese

Domestic geese are raised for their meat, large eggs, feathers, and sometimes their ability to weed crops or act as watchdogs. They are large, hardy, aggressive, noisy birds that need little attention when mature and may live for 30 years. There are at least nine recognized breeds of domestic geese. Of them, the Chinese and African breeds do best in the tropics.

- African: Distinctive black knob on the head; black bill; light-brown head; ash-brown wings and neck. Good layer, but dark pinfeathers make it an unattractive meat bird. They produce about 45-90 eggs per year.
- Chinese: The two varieties are brown and white; smaller and more swan-like than other breeds. They produce 40 to 65 eggs per bird per year.
- Toulouse: Loose-feathered; broad, deep body; pale orange beak, dark gray back shading to white breast, deep orange shank and toes. They produce about 35 to 50 eggs per year.
- Emden: Tight-feathered white body. Egg production averages 30 to 40 per year under good management.

Table B-1: Geese Weights

Breed	Weight Year-Old Male		Weight for Year-Old Female	
African	9 kg	20 lbs	8 kg	18 lbs
Chinese	5.5 kg	12 lbs	4.5 kg	10 lbs
Toulouse	12 kg	26 lbs	9 kg	20 lbs
Emden	12 kg	26 lbs	9 kg	20 lbs

Geese mate selectively and for life. Flocks should have at least one gander (male) for every two females.

Geese like swimming, but do not need to do so to breed. Eggs can be hatched by the mother or by a female chicken, which can care for up to six goslings (chicks). Keep eggs under a hen moist, and mark and turn them each day; they are too big for a hen to turn. No brooder is needed for goslings, but they should be kept warm and dry for the first few weeks. If housed, allow 0.09 square meters (1 square foot) per bird by two weeks of age on deep litter. Larger feeders and waterers are needed for goslings than for young chickens. Goslings do not need housing after six weeks.

Ideally, feed geese a 20 to 22 percent protein starter feed in pellet form. They can go on to range from 2 to 6 weeks of age. A 1 meter (3 foot) fence will confine them. If pasture is plentiful, geese do not need more than 0.5 to 1 kilograms (1 to 2 pounds) of supplemental

Appendix B: Other Poultry

feed per bird per week, and then only until they are 12 weeks old. Provide grit throughout the growing period.

Geese are selective grazers; they will not eat tough, dry grasses or some other plants. Thus, they can be confined in orchards, vineyards, and fields of strawberries (until blossom time), sugar beets, maize (once shoots have toughened), cotton, and some other crops. Start with 6-week-old goslings, providing them with shade and water and giving them a little grain in the evening if weeds and grass aren't abundant.

Most geese are marketed when they are 5 to 6 months old and weigh 5 to 7 kilograms (11 to 15 pounds), depending on breed. Geese are difficult to pluck; often they are dipped in melted wax, and the feathers are removed after the wax hardens. Re-melt and reclaim the wax, wash feathers in a solution of detergent or borax and washing soda (sodium carbonate). In some areas, goose down (small feathers) fetches a good price in the market.

Guinea Fowl

Guinea fowl originated in Africa, where there are a number of wild species. In ancient times, Greeks and Romans raised them as meat birds, and today they are prized by some people for their tasty meat, which competes favorably with wild game birds in price.

There are three varieties of domestic guinea fowl: pearl guinea (purplish-grey with white flecks); lavender guinea (light grey or lavender with white flecks); and white guinea (all white). The most common is the pearl guinea.

Guinea fowl are more difficult to raise profitably than chickens because they are wilder—they hide their eggs and do not take containment well. They may mate with chickens, but the offspring are sterile.

It is difficult to distinguish male and female guinea fowl. Males have a slightly larger helmet (comb) and wattles and a coarser head, but this is hard to see. Most people listen to their voices—the female call sounds like “buckwheat, buckwheat”; the male has a one-syllable shriek—but since the flock usually all call at once, sex differentiation remains difficult. In the wild, guineas mate in pairs. In controlled flocks, one male usually is kept for every four or five females.

Guinea keets (chicks) may be raised by their mothers, but a broody hen usually does a better job, staying on the eggs until most are hatched (about 28 days), keeping the keets out of wet grass, and perhaps teaching them to enter the chicken shelter in the evening. Eggs can also be artificially incubated at 39.4°C (103°F) in a still-air (no fan) incubator for the first three

weeks, and 40°C (104°F) for the last week. If you use a brooder, keep the temperature at 37.8°C (100°F) for the first week, and reduce by 2.8°C (5°C) each week thereafter.

Ideally, keets should have a 25 percent protein starter mash until 6 weeks of age, and then should be switched to a 15 percent grower mash to supplement the feed they find on range. Feed in the late afternoon so they return to the shelter at night.

Guinea eggs are smaller than chicken eggs, averaging 40 grams (1.4 ounces). A well-managed hen may lay 100 eggs a year. Collect all but two or three from a nest when you find it, so the hen feels safe returning to it, and don't disturb her while she is laying.

Guineas usually are 16 to 18 weeks old when sold for meat. At that age, they weigh 1.25 to 1.5 kilograms (2¾ to 3½ pounds).

Turkeys

Originally a hardy bird of the North American forests, turkeys have been developed into many meaty but difficult-to-breed varieties, mainly the Bronze and the White. You can still order turkeys that are closer to their wild cousins—they have much smaller breast size and can thus breed more easily. The new breeds are unintelligent, prone to panicking and stampeding at the slightest actual or imagined provocation. They can run into walls or fences and break their necks or pile into corners and smother. Poults (chicks) can starve to death unless they are taught to eat and drink. Very large turkeys are often too fat to mate and must be artificially inseminated.

Turkeys also are more susceptible to disease than chickens. They catch cold easily and are subject to coccidiosis, fowl pox, and parasites, but their most dangerous disease is blackhead (lethargy, loss of appetite, yellow diarrhea, darkened head, followed by death). Turkeys should be raised well away from chickens unless the farmer has a lot of experience with both species.

In turkey flocks, one gobbler (male) is needed to breed with each 10 hens. Eggs take 26 to 28 days to hatch. Watch the gobblers, because they often try to break the eggs.

Hatching and brooding turkeys artificially is a difficult business. A broody chicken will do a good job, but that increases the chance of disease. Turkeys are susceptible to two protozoan diseases: coccidiosis and blackhead. Meanwhile, the chicken is only prone to coccidiosis. Eggs under chickens must be hand-turned. Poults need a 28 percent protein starter feed and larger equipment than chickens. It is better, if possible, to buy poults when they are 6 to 8 weeks old.

Appendix B: Other Poultry

Growing turkeys need exercise on a range and plenty of grass, supplemented with grain and protein. When confined, they may eat up to 45 kilograms (100 pounds) of well-balanced feed by 24 weeks of age, when they will weigh 4.5 to 8.2 kilograms (10 to 18 pounds).

Pigeons

Once a flock of pigeons is established, they can be practically self-sustaining. The common Rock pigeon—the one that throngs city parks—can be kept, but better, larger breeds are the White King and Giant Homer.

Any waterproof, easily cleaned house will do, as will an unused portion of a shed. In dark corners of the house, place nesting shelves with lips so the eggs don't roll off. Cats, dogs, snakes, and rats eat pigeons, so place the house on legs or poles.

Pigeons stay close to home, so they don't need containment. If they are contained, give them well-balanced chicken feed. Treat them for parasites and coccidiosis as you would treat chickens.

A breeding pair will produce 10 or more squab (young pigeons) each year, two at a time. Squabs are usually eaten when they are 25 to 30 days old, when they are completely feathered but have not begun to fly. At that age they weigh 400 to 680 grams (14 to 24 ounces). A mature pigeon may live 12 years or more and may weigh 800 grams (1¾ pounds).

Appendix C: Farmer-Specific Assessment Criteria

1.	Date:
2.	Farmer name:
3.	Location:
4.	Number of birds:
5.	Age of birds:
6.	Breed source:
	Meat:
	Eggs:
7.	Feed source:
8.	System of operation:
9.	History of prior advisory assistance received:
10.	Visual appearance of birds:
11.	Number of years farmer has kept chickens:
12.	Other:

#	Subject	Existing	Potential	Gap/Comments	Ref. Page #
13.	Breed Source				
	Egg Production				
	Meat Production				
	Body Weight Average				
14.	Feeding/Nutrition				
	a. Nutrition				
	b. Feeding equipment				
	c. Water equipment				
	d. Layout				
	e. Grit/shells				
	f. Feed storage				
	g. Feed sources				
15.	Disease and Control				
	a. Vaccinations				
	- Newcastle				
	- Fowl pox				
	- Marek's				
	- Inf. bronch.				
	- Other				
b. Coccidiosis					
c. Other disease					

Appendix C: Farmer-Specific Assessment Criteria

#	Subject	Existing	Potential	Gap/Comments	Ref. Page #
	d. Antibiotics				
16.	Parasite Control				
	a. Internal				
	b. External				
17.	Cannibalism				
18.	Rodents, Wild				
	Birds and Predators				
19.	Nesting Provisions				
	a. Space				
	b. Management				
20.	Brooding/Rearing				
	a. 1 day – 8 weeks				
	b. 8 – 20 weeks				
21.	Management Systems				
	a. Range				
	b. Deep litter				
	c. Cage				
	d. Slatted floor				
22.	Layer Material				
	a. Stress				
	b. Other				
23.	Housing				
	a. Range				
	b. Deep litter				
	c. Slatted floor				
	d. Cage				
24.	General Management				
	a. Tender Loving Care				
	- Interest				
	- Routine				
	b. Sanitation				
	- All out/in				
	- Cleaning				
	- Isolation				
	- Hygiene				

Appendix C: Farmer-Specific Assessment Criteria

#	Subject	Existing	Potential	Gap/Comments	Ref. Page #
	- Feed storage				
	c. Daily sanitation				
	- Waterers				
	- Feeders				
	- Litter/droppings				
	d. Cost reduction				
	- Egg collection				
	- Feed wastage	l			
	- Space use				
	- Culling				
	- Upkeep				
	- Keeping males				
	- Joint efforts				
25.	Sex Separation				
26.	Stress Reduction				
	- Disturbances				
	- Feed changes				
	- Caretaker changes				
	- Routine changes				
	- Violent weather				
	- Moving birds				
	- Dampness				
	- Ventilation control				
27.	Lighting				
28.	Marketing				
	- Prices				
	- Seasonal considerations				
	- Yolk/shell color				
	- Egg cleanliness				
	- Meat qualities				
	- Egg grading				
	- Meat grading				
	- Handling and storage				
29.	Other				

Appendix C: Farmer-Specific Assessment Criteria

#	Subject	Existing	Potential	Gap/Comments	Ref. Page #
	a. Incubation				
	- Natural				
	- Artificial				
	b. Country chicken				
	- Breed improvement				
	- Debeaking				
	- Night protection				
	- Feeding				
	c. Forced molting				
	- Methods				
	- Economics of				
	d. Progress gauge				
	- Body weight gain				
	- Egg production curve				
	- Uniformity of growth				
	- Feed consumption				
	- Mortality rate				

Appendix D: Feed Formulation Chart

Key	Ingredient	Lbs. in Mix	Protein		Fat		Fiber		Met. Energy		Calcium		Phosphorus	
				Amt.		Amt.		Amt.	Kcal/lb	Amt.		Amt.		Amt.
1	Alfalfa meal: 17%		.170*		0.27		.260		490		.015		.002	
2	Blood meal		.80		.01		.01		1400		.003		.002	
3	Barley		.116		.019		.050		1205		.001		.005	
4	Coconut oil meal		.20		.06		.12		675		.002		.006	
5	Corn (maize)		.085		.035		.029		1530		.000		.003	
6	Corn gluten meal: 42%		.429		.023		.040		1475		.002		.004	
7	Cottonseed meal: 44%		.440		.012		.110		910		.002		.011	
8	Cottonseed meal: 41%		.416		.016		.110		1000		.002		.011	
9	Cottonseed meal: 50%		.500		.001		.008		1010		.002		.014	
10	Feather meal		.850		.030		.010		1078		.002		.008	
11	Fishmeal, anchovy		.650		.038		.001		1020		.045		.028	
12	Fishmeal herring		.706		.075		.001		1350		.029		.022	
13	Fishmeal, menhaden		.600		.075		.001		1200		.050		.028	
14	Fishmeal, sardine		.650		.040		.001		1300		.045		.027	
15	Limestone flour										.378			
16	Meat meal w/bone: 45%		.450		.080		.025		780		.110		.050	
17	Meat meal w/bone: 50%		.506		.095		.020		870		.106		.051	
18	Meat meal: 55%		.550		.080		.025		910		.080		.040	
19	Peanut meal: 45%		.450		.068		.130		1100		.002		.006	
20	Rice, broken		.073		.004		.004		1550		.000		.001	
21	Rice bran (variable)		.125		.133		.034		1000		.001		.014	

Appendix D: Feed Formulation Chart

Key	Ingredient	Lbs. in Mix	Protein		Fat		Fiber		Met. Energy		Calcium		Phosphorus	
				Amt.		Amt.		Amt.	Kcal/lb	Amt.		Amt.		Amt.
22	Rice polish		.110		.120		.066		1500		.000		.001	
23	Sesame seed meal		.420		.070		.023		1200		.020		.013	
24	Sorghum grain (milo)		.090		.028		.065		1500		.000		.003	
25	Soybean meal: 42%		.420		.035		.070		1100		.002		.006	
26	Soybean meal: 44 %		.440		.005		.030		1020		.002		.006	
27	Soybean meal: 50%		.500		.005		.120		1150		.002		.007	
28	Wheat bran		.150		.030		.030		510		.001		.010	
29	Brewer's dried yeast		.446		.011				840		.001		.014	
30	Dicalcium phosphate						.020				.270		.191	
31	Bone meal, straight		.121		.032		.001		421		.290		.136	
32	Cassava (yucca, manioc) meal		.001		.001				1597		.001		.002	
33	Molasses		.030											
T	TOTALS													
V	VALUES FOR RATION													
AV	ADJUSTED VALUES													
AR	ALLOWANCES OR REQUIR.													

** This means that in every pound of alfalfa meal there is 0.170 pound of protein, and in every kilogram of alfalfa meal there is 0.170 kilogram of protein, and so on.*

Appendix D: Feed Formulation Chart

Key	Pyridoxine		Folacin		Biotin		Thiamine		Arginine		Cystine		Glycine		Histidine	
	mg/lb	Amt.	mg/lb	Amt.	mg/lb	Amt.	mg/lb	Amt.	lb/lb	Amt.	lb/lb	Amt.	lb/lb	Amt.	lb/lb	Amt.
1			3.1		.15		3.3		.009		.004		.008		.003	
2									.035		.014		.042			
3	1.5		.3		.08		2.6		.006		.002		.004		.003	
4									.023		.002		.011			
5	3.8		.1		.03		2.1		.005		.001		.005		.002	
6	3.6		.1		.09		.1		.014		.006		.015		.010	
7			.5		.56		4.1		.045		.009		.019		.001	
8			.4		.50		3.7		.041		.008		.019		.010	
9			.6		.61		4.3		.044		.009		.020		.013	
10									.056		.031		.068		.004	
11	2.6		1.1		.07		.6		.036		.007		.046		.013	
12	2.6		1.1		.07		.6		.040		.006		.042		.013	
13	2.6		1.1		.07		.6		.036		.009		.038		.014	
14	2.6		1.1		.07		.6		.027		.008		.045		.013	
15																
16			.2				.4		.038		.005		.061		.008	
17			.2				.5		.040		.006		.066		.009	
18			.2				.5		.030		.043		.071		.010	
19							3.4		.049		.007		.023		.015	
20							2.0		.006		.001		.004		.001	
21							10.25		.011		.001		.001		.001	
22							8.35		.005		.001		.007		.001	
23							.8		.046		.006		.029			
24	2.1		.1		.13		2.0		.003		.002		.003		.003	

Appendix D: Feed Formulation Chart

Key	Pyridoxine		Folacin		Biotin		Thiamine		Arginine		Cystine		Glycine		Histidine	
	mg/lb	Amt.	mg/lb	Amt.	mg/lb	Amt.	mg/lb	Amt.	lb/lb	Amt.	lb/lb	Amt.	lb/lb	Amt.	lb/lb	Amt.
25			.3		.14		2.9		.032		.006		.023		.010	
26			.3		.14		3.0		.034		.007		.024		.011	
27			.4		.15		1.2		.038		.008		.027		.012	
28	2.4		.2		.05		3.3		.075		.025		.075			
29	19.4		4.2		.45		41.3		.022		.025		.017		.011	
30																
31							.2									
32																
33																
T																
V																
AV																
AR																

Appendix D: Feed Formulation Chart

Key	I. Leucine		Leucine		Lysine		Methionine		P. Alanine		Threonine		Tryptophan		Tyrosine		Valine	
	mg/lb	Amt.	mg/lb	Amt.	mg/lb	Amt.	mg/lb	Amt.	lb/lb	Amt.	lb/lb	Amt.	lb/lb	Amt.	lb/lb	Amt.	lb/lb	Amt.
1	.009		.013		.010		.003		.008		.007		.002		.008		.010	
2					.069		.009						.011					
3	.006		.009		.006		.002		.007		.004		.002		.004		.007	
4					.005		.003						.002					
5	.005		.011		.002		.001		.005		.004		.001		.005		.001	
6	.023		.076		.008		.010		.029		.014		.002		.010		.022	
7	.019		.026		.018		.007		.024		.015		.005		.013		.022	
8	.016		.024		.017		.006		.022		.014		.005		.012		.020	
9	.021		.030		.019		.008		.028		.019		.005		.015		.025	
10	.038		.074		.015		.005		.028		.040		.006		.024		.065	
11	.030		.050		.060		.020		.023		.023		.008		0.18		.029	
12	.032		.051		.057		.020		.026		.026		.008		.021		.032	
13	.030		.052		.052		.020		.023		.023		.007		.019		.030	
14	.031		.052		.052		.020		.023		.023		.005		.018		.026	
15																		
16	.015		.028		.031		.006		.015		.015		.002		.015		.013	
17	.017		.031		.035		.007		.018		.018		.002		.017		.014	
18					.025		.007						.005					
19					.017		.004						.006					
20					.003		.002						.001					
21					.006		.002						.002					
22					.005		.002						.001					
23					.012		.015						.008					

Appendix D: Feed Formulation Chart

Key	I. Leucine		Leucine		Lysine		Methionine		P. Alanine		Threonine		Tryptophan		Tyrosine		Valine	
	mg/lb	Amt.	mg/lb	Amt.	mg/lb	Amt.	mg/lb	Amt.	lb/lb	Amt.	lb/lb	Amt.	lb/lb	Amt.	lb/lb	Amt.	lb/lb	Amt.
24	.006		.016		.002		.002		.005		.003		.001		.004		.006	
25	.021		.033		.027		.006		.021		.016		.006		.014		.022	
26	.025		.029		.029		.006		.022		.017		.007		.014		.024	
27	.028		.037		.032		.007		.024		.019		.008		.015		.026	
28	.007		.011		.007		.004		.006		.005		.003		.004		.008	
29	.021		.032		.030		.007		.018		.021		.005		.015		.023	
30																		
31																		
32																		
33																		
T																		
V																		
AV																		
AR																		

Appendix D: Feed Formulation Chart

Key	Manganese		Dodium		Iron		Copper		Iodine		Potassium		Magnesium		Zinc	
	mg/lb	Amt.	mg/lb	Amt.	mg/lb	Amt.	mg/lb	Amt.	lb/lb	Amt.	lb/lb	Amt.	lb/lb	Amt.	lb/lb	Amt.
1	30.9		.002		191		7.7		.25		.020		545		15.9	
2																
3	8.3		.000		27		3.9		.02		.006		636		7.8	
4																
5	2.2		.000		13		1.8		.02		.004		771		5.5	
6	3.3		.001		181		12.8				.000		227		63.4	
7	9.1		.001		69		9.7		.05		.015		2633			
8	9.1		.001		69		9.7		.05		.015		2633			
9	9.1		.001		69		9.7		.05		.015		2633			
10																
11	4.5		.007		254		3.8		.48		.005		863		95.6	
12	4.5		.007		254		3.8		.48		.005		863		95.6	
13	4.5		.007		254		3.8		.48		.005		863		95.6	
14	4.5		.007		254		3.8		.48		.005		863		95.6	
15	117.1		.001		1680						.001		5221			
16	5.6		.007		227		0.7		.59		.006		5130		170.2	
17	5.6		.007		227		0.7		.59		.006		5130		170.2	
18	4.1		.007		254		3.9		.51		.006		852		97.4	
19	11.6		.016		72						.005		432			
20	2.5		.000		11		1.8		.02		.006		439			
21	25.4		.000		88						.008		511			
22	6.1		Trace		73						.021					
23	10.9		---		11						.022		1304		68.8	
24	6.6		.000		22		7.2		.01		.004		998		7.0	

Appendix D: Feed Formulation Chart

Key	Manganese		Dodium		Iron		Copper		Iodine		Potassium		Magnesium		Zinc	
	mg/lb	Amt.	mg/lb	Amt.	mg/lb	Amt.	mg/lb	Amt.	lb/lb	Amt.	lb/lb	Amt.	lb/lb	Amt.	lb/lb	Amt.
25	12.5		.003		59		16.6		.06		.020		1226		66.4	
26	13.0		.003		61		17.1		.06		.021		1233		68.1	
27	13.9		.004		64		18.0		.07		.024		1264		71.4	
28	46.7		.002		44		8.5		.00		.013		2315			
29	2.6		.001		58		15.0		.00		.017		1044		17.6	
30											.001		13484		2.3	
31	13.8		.005		381		7.4				.002		2946		193.0	
32																
33																
T																
V																
AV																
AR																

Appendix D: Feed Formulation Chart

Key	Vitamin A		Vitamin D3		Riboflavin		d-Pant. Acid		Niacin		Choline		Vitamin B12		Vitamin E		Vitamin K	
	mg/lb	Amt.	mg/lb	Amt.	mg/lb	Amt	mg/lb	Amt	lb/lb	Amt	lb/lb	Amt	lb/lb	Amt.	lb/lb	Amt.	lb/lb	Amt.
1	100000				7.6		19.9		18.6		549		1.2		191.4		9.80	
2					.7		.5		14.2		300							
3	333				1.0		3.3		29.0		500				3.4			
4					1.5		2.8		13.0		500							
5	1500				.6		2.7		12.1		284		1.5		15.5		.05	
6	12328				.7		4.7		22.7		150				11.0			
7					2.1		8.1		20.7		1301				5.5			
8					2.1		8.1		20.7		1301				5.5			
9					2.1		8.1		20.7		1301				5.5			
10					.9		3.7		7.9		400		32.2					
11					2.2		4.2		43.0		1595		99.4		104.5		.19	
12					5.2		4.0		38		1800		99.1		100		.19	
13					2.2		4.0		25		1400		99.0		105.5		.19	
14					2.5		4.0		28		1300		99.9		104.4		.19	
15																		
16					1.9		1.4		19		600		44.8					
17					1.5		1.8		21		750		44.8					
18					2.0		1.7		22		850		44.8					
19					2.4		24.0		75		800							
20					.2		2.4		8.5		460				17.0		.01	
21					1.4		10.4		129.0		450				6.0			
22					.9		4.5		325.0		460				6.0			

Appendix D: Feed Formulation Chart

Key	Vitamin A		Vitamin D3		Riboflavin		d-Pant. Acid		Niacin		Choline		Vitamin B12		Vitamin E		Vitamin K	
	mg/lb	Amt.	mg/lb	Amt.	mg/lb	Amt	mg/lb	Amt	lb/lb	Amt	lb/lb	Amt	lb/lb	Amt.	lb/lb	Amt.	lb/lb	Amt.
23					1.5		2.5		6.0		680							
24	333				.6		5.8		21.8		346				13.2			
25	166				1.5		6.6		12.2		1247		.9		.6			
26	160				1.5		6.6		12.2		1247		.9		.6			
27					1.4		7.2		9.8		1255		.9		.6			
28					1.1		6.0		50.9		446				7.7			
29					15.9		49.9		203.4		1766		.5					
30																		
31					.4		1.1		1.9		100							
32																		
33																		
T																		
V																		
AV																		
AR																		

Appendix E: Feed Requirements

Energy Requirements

Table E-1: Energy Requirements

	0–8 weeks	8–20 weeks	20 weeks and on
Metabolizable energy (ME)			
Calories per lb.	1,250	1,280	1,335
Calories per kg.	2,750	2,815	2,950

Vitamin Requirements

Table E-2: Vitamin Requirements

	0–8 weeks	9–20 weeks	20 weeks and On	Breeding Chickens
Units per kg/lb				
Vitamin A1	2,640/1,200	2,640/1,200	4,400/2,000	4,400/2,000
Vitamin D2	200/90	200/90	500/225	500/225
Amount (mg per kg/lb)				
Vitamin K	0.5/0.24			
Thiamin	1.7/0.8			
Riboflavin ³	2.4/1.3	1.7/0.8	2.2/1	3.7/1.7
Pantothenic acid ⁴	9.2/4.2	9.2/4.2	4.6/2.1	9.2/4.2
Niacin	26/12			
Pyridoxine	2.9/1.3		2.9/1.3	2.9/1.3
Vitamin E	Needed in feeds, but requirements unknown			

Notes:

International Units (IU).

International Chick Units (ICU).

Feeds only containing grain may not have enough riboflavin.

Feeds that have enough riboflavin usually have enough pantothenic acid.

Appendix E: Feed Requirements

Protein and Amino Acid Requirements

Table E-3: Protein and Amino Acid Requirements (percentage of total feed)

	0–8 weeks	9–20 weeks	20 weeks and on	Broilers: 0 weeks to sale
Crude protein	20	16	16-18	22
Amino acids				
² Arginine*	1.20	unknown	0.80	1.20
² Lysine*	1.10	0.70	0.50	1.10
² Methionine* (minimum)	0.45	0.35	0.28	0.45
¹ Cystine*	0.35	0.30	0.25	0.35
² Tryptophan*	0.20	0.18	0.15	0.20
Glycine	1.00	1.00	1.00	1.00
² Histidine	0.15	unknown	0.30	0.15
² Isoleucine	0.60	"	0.80	0.80
² Leucine	1.40	"	1.20	1.40
² Phenylalanine (minimum)	0.90	unknown	0.70	0.90
³ Tyrosine	0.70	"	1.00	0.70
² Threonine	0.60	"	0.55	0.60
² Valine	0.80	"	0.80	0.80

* Many feeds do not have enough of these acids.

Notes:

Remember, cystine is synthesized from methionine and is not essential unless methionine is limited.

Tyrosine is synthesized from phenylalanine and is not essential unless phenylalanine is limited.

Appendix E: Feed Requirements

Mineral Requirements

Table E-4: Mineral Requirements (Percentage of Total Feed)

	0–8 weeks	9–20 weeks	20 weeks and on	Breeding chickens
Calcium	1	1	2.75	2.75
Phosphorus	0.60	0.60	0.60	0.60
Salt	0.50	0.50	0.50	0.50
Potassium	0.20	0.16	—	—
Amount (mg per kg/lb)				
Manganese	55/25	—	—	33/15
Iodine	1.1/0.5	—	0.4/0.2	1.1/0.5
Magnesium	490/220			

Note: Mineral contents of a feed should not greatly exceed these levels; overuse of one may block utilization or digestion of another.

Maximum Limits of Feed Ingredient Use

# Source	Percentage of total feed weight
1. Alfalfa meal	5–10
2. Blood meal	4–5
3. Barley	20
4. Coconut oil meal (copra meal)	15–40 (depending on fiber content)
6. Maize (corn) gluten meal	15
7-9. Cottonseed meal	10–15
10. Feather meal	5–7
11-14. Fish meal	10–15
15. Limestone flour	4
16-18, 31. Meat and bone meals	10
19. Groundnut (peanut) meal	35
20. Rice, broken	30
21. Rice bran	10–15 (30 percent of high quality and low in fiber)
22. Rice polish	50
23. Sesame seed meal	30
25-27. Soybean meal	30
28. Wheat bran	15

Appendix E: Feed Requirements

# Source	Percentage of total feed weight
29. Brewer's yeast	5-10
32. Cassava (yucca, manioc) meal	Chicks: 10
	Layers: 20
Sweet potato meal	20
Wheat	50
Salt	0.5
Straw and rice hulls	0

Appendix F: Bibliography and Resources

Bibliography

- Biestes, H.E., and L.H. Schwarte. 1969. *Diseases of Poultry*. Iowa State University Press.
- Davies, Paul. 1999. *The Fifth Miracle: The Search for the Origin of Life*. New York, NY: Simon and Schuster, 1999.
- Ensminger, M.E. 1971. *Poultry Science*. Danville, Illinois: The Interstate Printers and Publishers.
- FAO. 1965. "Poultry Feeding in Tropical and Subtropical Countries." FAO Agricultural Development Paper No. 82. Rome: FAO.
- FAO. 1970. "Amino-acid Content of Foods and Biological Data on Protein." FAO Nutritional Studies No. 24. Rome: FAO.
- Florea, J.H. 1977. *ABC of Poultry Raising*. New York, NY: Dover Publications, Inc.
- Glos, Karma. *Humane and Healthy Poultry Production: A Manual for Organic Growers*. Chelsea Green Publishing, 2011.
- Laidlaw, A.F. 1962. "Training and Extension in the Cooperative Movement." FAO Agricultural Development Paper No. 74.
- Michael, Lerner I. 1965. *The Genetic Basis of Selection*. New York, New York: John Wiley and Sons.
- Morrison, Frank B. 1956. *Feeds and Feeding*. Ithaca, New York: The Morrison Publishing Company.
- Nradfield, D.J. 1966. "Guide to Extension Training." FAO Economic and Social Development Series No. 6.
- Price, G.J., and J.E. Reed. 1971. "Poultry Husbandry II: Notes for Students of Animal Husbandry." Rome: FAO.
- Salsbury, J.E. 1978. *Salsbury's Manual of Poultry Diseases*. Charles City, Iowa: Dr. Salsbury's Laboratories.
- Stewart, G.F., and J.C. Abbott. 1961. "Marketing Eggs and Poultry." FAO Marketing Guides No. 4.
- Thomann, W. 1968. "Poultry Keeping in Tropical Areas." Rome: FAO.
- Titus, H.W., and J.C. Fritz. 1972. *The Scientific Feeding of Chickens*. Fourth Edition. Danville, Illinois: The Interstate Printers and Publishers.
- Vohra, P. 1962. *Poultry Feed Mixing Manual*. New Delhi, India: USAID.
- Warren, D.C. 1966. *Practical Poultry Breeding*. Macentimetersillan Company, U.S.A.

Appendix F: Bibliography and Resources

Resources

Improving backyard poultry keeping, Overseas Development Institute: <http://www.odi.org.uk/sites/odi.org.uk/files/odi-assets/publications-opinion-files/5166.pdf>

International Livestock Research Institute: <http://www.ilri.org/>

International Rural Poultry Centre to Technical Assistance: <http://www.kyeemafoundation.org/content/irpc.php>

Modernizing Extension and Advisory Services: <http://www.meas-extension.org/>

Dolberg, F. "Poultry as a tool in human development: Historical perspective, main actors and priorities." FAO Smallholder Poultry Production Paper No. 6. Rome: FAO, 2013. <http://www.fao.org/docrep/013/al676e/al676e00.pdf>

Products and Profit from Poultry, FAO: <http://www.fao.org/docrep/015/i2465e/i2465e00.pdf>

Appendix G: Glossary

Breeder	Sexually mature chicken used to produce fertile eggs
Broiler	Chicken grown for meat
Capon	Castrated male chicken
Cockerel	Male chicken less than 1 year old
Fryer	Young broiler, usually less than 1 year old
Grower	Intermediate stage between chick and adult
Hen	Female chicken more than 1 year old
Layer	Female chicken, usually 21 weeks or older, kept for eggs
Pipping	Using their upper beaks, chicks peck a hole through the shell, then continue to peck until the shell is weakened enough so that it can be entirely broken open
Pullet	Female chicken less than 1 year old
Roaster	Fat, heavy broiler, usually more than 10 weeks old
Rooster (Cock)	Male chicken more than 1 year old