

## **ESP: Teaching English for specific purposes**

### **Peace Corps**

**Mary Schleppegrell and Brenda Bowman**

Prepared for Peace Corps by Center for Applied Linguistics Washington, DC

Peace Corps  
Information Collection & Exchange  
Manual M0031  
September 1986

### **INFORMATION COLLECTION & EXCHANGE**

Peace Corps' Information Collection & Exchange (ICE) was established so that the strategies and technologies developed by Peace Corps Volunteers, their co-workers, and their counterparts could be made available to the wide range of development organizations and individual workers who might find them useful. Training guides, curricula, lesson plans, project reports, manuals and other Peace Corps-generated materials developed in the field are collected and reviewed. Some are reprinted "as is"; others provide a source of field based information for the production of manuals or for research in particular program areas. Materials that you submit to the Information Collection & Exchange thus become part of the Peace Corps' larger contribution to development.

#### **Information about ICE publications and services is available through:**

**Peace Corps**  
Information Collection & Exchange  
1111 - 20th Street, NW  
Washington, DC 20526  
USA

Website: <http://www.peacecorps.gov>  
Telephone : 1-202-692-2640  
Fax : 1-202- 692-2641

Add your experience to the ICE Resource Center. Send materials that you've prepared so that we can share them with others working in the development field. Your technical insights serve as the basis for the generation of ICE manuals, reprints and resource packets, and also ensure that ICE is providing the most updated, innovative problem-solving techniques and information available to you and your fellow development workers.

Prepared for the Peace Corps by the Center for Applied Linguistics under Contract #205-2723, August 14, 1986.

This manual may be reproduced and/or translated in part or in full without payment of royalty. Please give standard acknowledgement.

The authors would like to thank John L. D. Clark, JoAnn Crandall, and Karen Willetts of the Center for Applied Linguistics, and John Guevin and Maureen Delaney of the Peace Corps, for their valuable editorial comments. We would also like to thank Joyce Simpkins of the Center for Applied Linguistics for her help with the figures and diagrams.

### **Introduction**

This Manual is a guide to the development of a program of instruction in English for Specific Purposes (ESP). Step-by-step procedures are outlined for assessing student needs, setting achievable goals, designing a program, and selecting - appropriate materials and activities for the classroom. The Manual also describes the four language skills: listening, reading, writing, and speaking, and provides suggestions for teaching these skills as well as grammar and study skills. General guidelines are also presented for program and classroom management. A special section addresses the needs of students who are preparing to study abroad, and a resource section reviews materials which are available to Peace Corps ESP teachers and gives directions for ordering them from Peace Corps' Information Collection and Exchange (ICE).

This Manual is not an exhaustive review of techniques and approaches to teaching English as a Foreign Language (EFL). Other resources will be needed for that purpose by the Volunteer with no previous EFL teaching experience. The Manual does focus on the special case in EFL; teaching English for Specific Purposes, and the particular ways that a EFL program should be structured for the teaching of ESP.

## **Chapter One - The teacher, the student, and English for specific purposes**

### **English for specific purposes**

If you have had previous experience as a teacher of English as a Foreign Language (EFL), your first question on receiving your current assignment to teach ESP may be: "How is ESP different from EFL?" The major difference between ESP and EFL lies in the learners and their purposes for learning English. ESP students are adults who already have some familiarity with English and are learning the language in order to communicate a set of professional skills and to perform particular job-related functions. An ESP program is therefore built on an assessment of purposes and needs and the functions for which English is required .

ESP is part of a larger movement within language teaching away from a concentration on teaching grammar and language structures to an emphasis on language in context. ESP covers subjects ranging from accounting or computer science to tourism and business management. The ESP focus means that English is not taught as a subject divorced from the students' real world; instead, it is integrated into a subject matter area important to the learners.

EFL and ESP differ not only in the nature of the learner, but also in the scope of the goals of instruction. Whereas in EFL all four language skills; listening, reading, speaking, and writing, are stressed equally, in ESP a needs assessment determines which language skills are most needed by the students, and the program is focused accordingly. An ESP program, might, for example, stress the development of reading skills in students who are preparing for graduate work in engineering; or it might stress the development of conversational skills in students who are studying English in order to become tour guides.

ESP integrates subject matter and English language instruction. Such a combination is highly motivating because students are able to apply what they learn in their English classes to their major field of study, whether it be computer science, accounting, business management, economics, or tourism. Being able to use the vocabulary and structures that they learn in a meaningful context reinforces what is taught and increases students' motivation.

The students' abilities in their subject-matter fields, in turn, enhance their ability to acquire English. Subject-matter knowledge gives them the context they need to understand the English of the classroom. The ESP class takes subject-matter content and shows students how the same information is expressed in English. The teacher can exploit the students' knowledge of the subject matter in helping them learn English faster.

Figure 1 summarizes what is meant by English for Specific Purposes. The "specific" in ESP refers to the specific purpose for learning. Students approach the learning of English through a field that is already known and relevant to them. This means that they are able to use what they learn in the ESP classroom right away in their work and studies. The ESP approach enhances the relevance of what the students are learning and enables them to use the English they know to learn even more English, since their interest in their field will motivate them to interact with speakers and texts.

Figure 1. ESP assesses needs and integrates motivation, subject matter and content for the teaching of relevant skills

## English for Specific Purposes

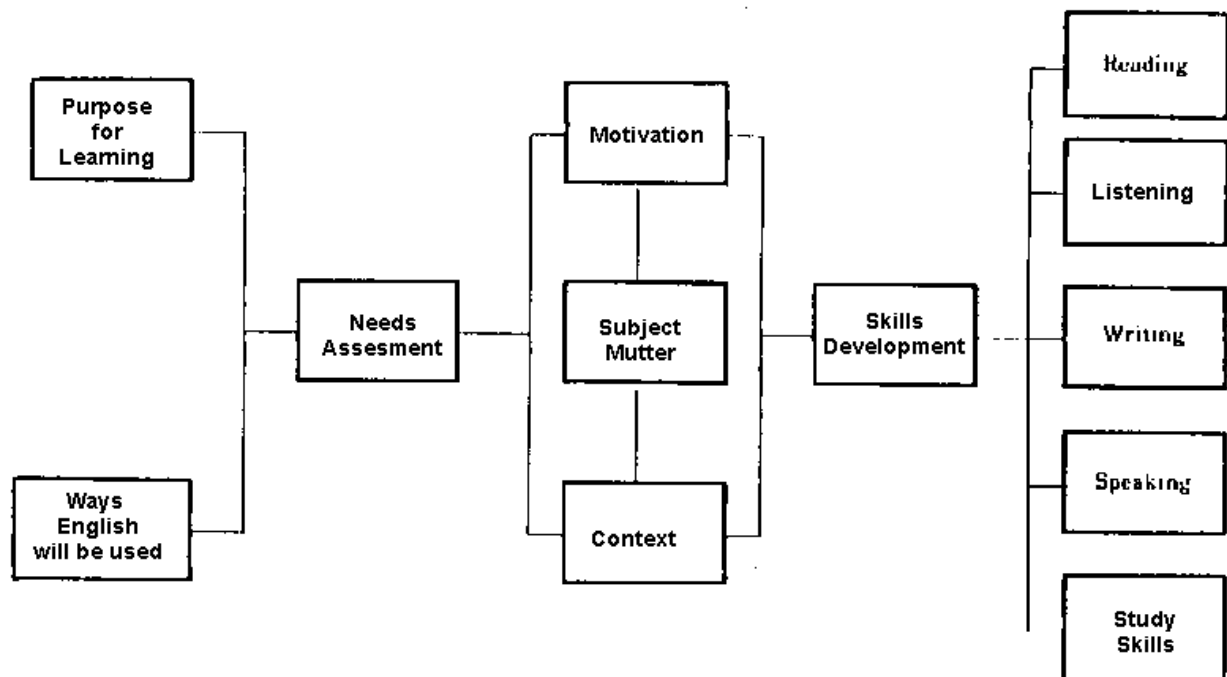

### The role of the teacher

Some of you may already have experience teaching English as a Foreign Language (EFL). If so, you can draw on your background in language teaching. This Manual will help you identify the ways in which your teaching skills can be adapted for the teaching of English for Specific Purposes. In addition, you will need to seek out content-area specialists for assistance in designing appropriate lessons in the subject matter field you are teaching.

If you are a subject-area specialist with no experience in teaching EFL, this Manual will be a valuable resource as it takes you through the process of needs assessment and program design and offers concrete suggestions for classroom activities. You will need to carefully study the EFL techniques suggested here to see how your subject-matter knowledge can be used in the teaching of language skills.

The Peace Corps ESP teacher must fill many roles. You may be responsible for organizing courses, for setting learning objectives, for establishing a positive learning environment in the classroom, and for evaluating student progress.

1. Organizing Programs: You will set goals for the students and then translate those goals into an instructional program with hourly, daily, and weekly activities. One of your primary tasks will be management; selecting and organizing course materials, supporting the students in their efforts, and providing them with feedback on their progress.

2. Setting Goals and Objectives: You arrange the conditions for learning in the classroom and set long-term goals and short-term objectives for student achievement. Your awareness of students' capabilities is a crucial factor in designing a program with realistic goals that takes into account the students' contribution to the learning situation.

3. Establishing a Learning Environment: Your communication skills establish the classroom atmosphere. Language is acquired by students when they have opportunities to use the language in interaction with other speakers. As their teacher, you may be the only native speaker of English available to students, and although your time with any one student will be limited, you can model good communication skills in the classroom. This means that in your interactions with students you should listen carefully to what they are saying (or trying to say) and reflect your understanding or lack of understanding back at them through your responses. Language learning is a great risk-taking endeavor for students in which they must make many errors in order to succeed. Language learners are handicapped in the classroom because they are unable to use their native language competence to present themselves as knowledgeable adults. Instead, they have to take on the role of inarticulate learner. You should create an atmosphere in the language classroom which supports the students. The non-native speaker of English must be self-confident in order to communicate, and you have the responsibility to help build the learner's confidence.

4. Evaluating Students: Finally, you are a resource person who helps students identify their language-learning problems and find solutions to them. You identify the skills that students need to focus on, and take responsibility for making choices which determine what and how the students learn. You will serve as a source of information to the students about how they are progressing in their language learning.

### **The role of the student**

What does the learner bring to the classroom and what is the task the language learner faces? The learners come to the ESP class with a specific focus for learning, subject matter knowledge, and well-developed adult learning strategies. They face the task of developing English language skills to reflect their native-language knowledge and skills.

1. Focus for Learning: The ESP student has a particular purpose and focus for learning. People learn languages when they have opportunities to understand and work with language in a context that they comprehend and find interesting. ESP is a vehicle for such opportunities. Students will acquire English as they work with materials which they find interesting and relevant and which they can use in their professional work or further studies. Successful learners pay attention to the meaning of the language they hear or read and do not focus primarily on the linguistic input or isolated language structures. The ESP student is particularly well disposed to focus on meaning in the subject-matter field. In ESP, English should be presented not as a subject or body of facts to be learned in isolation from real use, nor as a mechanical skill or habit to be developed. Rather, English should be presented in authentic contexts to acquaint the learners with the particular ways the language is used in functions that they will need to perform in their specialty fields.

2. Subject-Matter Knowledge: Learners in the ESP classroom are able to make a real contribution to the language learning process. They are generally aware of the purposes for which they will need to use English. Having already oriented their training toward a specific field, they see their English instruction as complementing this orientation. Knowledge of the speciality area enables the students to identify a real context for the vocabulary and structures

of the ESP classroom. In this way, the learners can take advantage of what they already know about the subject matter field to learn English.

3. Adult Learning Strategies: Learning as an adult has advantages -- adults must work harder than children to learn a new language, but the learning strategies they bring to the task enable them to learn faster and more efficiently. The skills they have already developed in reading and writing their native languages will make learning English easier. Although the English of the students you will be working with will most likely be quite limited, the language learning abilities of the adult in the ESP classroom are potentially great. Language learning continues naturally throughout our lives. Educated adults are constantly learning new language behavior in their native languages; expanding vocabulary, becoming more articulate in their fields, and modifying their linguistic behavior in new situations or new roles. ESP students can tap these natural competencies in learning English.

To summarize,

ESP combines

- purpose
- subject matter
- motivation
- context
- relevant skills

Your role in the ESP classroom is to

- organize programs
- set goals and objectives
- establish a positive learning environment
- evaluate students' progress

Your students bring to ESP

- focus for learning
- subject matter knowledge
- adult learning strategies

## **Chapter two: Analyzing needs**

### **Purpose of the needs assessment**

Three reasons you should conduct a needs assessment prior to development of an ESP course are:

- 1) to become acquainted with the institution and its requirements,
- 2) to identify how learners will use English in their technical fields, and
- 3) to assess the students' current level of understanding of spoken English.

A series of interviews and observations, as suggested here, will allow you to take advantage of the resources available at your institution to help you identify the particular skills that the learners will need to perform in English, and to create opportunities for students to engage in activities that give them practice in understanding and using language structures to perform those skills. The process outlined here will prepare you to select activities and materials which are appropriate to the learners' needs and level of proficiency.

The needs assessment phase of ESP program development will give you a better understanding of your students' needs and capabilities as English learners. Identifying these needs and capabilities involves identifying the functions for which the students will use English and collecting samples of authentic language. In analyzing this language your focus should not just be on the grammar of the language, but also on how it is used in the academic or professional context: that is, what role English plays in that specialty field and what students must learn to be able to use English in their technical work.

The main questions answered by the needs assessment, then, are:

What are the purposes for which the students will use English? Will it be mainly for oral communication, written communication, reading, or to do research?

What language skills will the students need to develop in order to perform these tasks? Will the receptive skills of reading and listening be most important, or the productive skills of writing and speaking -- or some other combination?

Your needs assessment will help you to answer these questions.

### **The needs assessment process**

The process of needs assessment requires interviews and interactions with three sources of information at your institution: the administrators, the content-area instructors, and the students themselves.

1. Program administrators should be interviewed soon after your arrival at your site. It is important that you integrate yourself into the new institution; introducing yourself to the administration will give you the opportunity to find out what is expected from you as a new member of the teaching staff, and for you to let them know what the goals of the Peace Corps program and your course are in the context of broader host country goals.

Ask the administrators about the institution's grading and examination requirements. These requirements may put some constraints on the program you develop. In many countries standard examinations are developed by the government or educational institutions. If you are required to give such an exam at the end of your course, your teaching must take this into account. Even if you do not agree with the emphasis on or focus of the examinations, your students will be dissatisfied if your program ignores material which is necessary for their success within the institution.

Ask about facilities and equipment which are available to you as a language teacher. Find out if the institution has any funds available for you to acquire materials or equipment. Finally, ask to be introduced to the subject matter instructors in the area of ESP that you will teach (instructors in computer science, for example, if you will be teaching English for computer science students).

2. Content-area instructors are valuable resources for the ESP teacher. In the ESP course is English for Accounting, for example, the instructors in the accounting department of the institution should become close working partners with the ESP instructor to share information about the students' needs for English and the ways students will use the English they are learning. Ask the instructors for samples of English-language materials used in subject-matter teaching: textbooks, research articles, and, if possible, class handouts and sample exercises. It may be useful for you to look at copies of old exams and materials which students used in secondary schools, if they are available. These can be adapted and used in the ESP class to reinforce what is taught in the content-area classes. Ask the subject-matter teacher to show you any equipment and laboratory facilities used by the students. Spend some time in the

laboratory to determine first-hand the kinds of interactions that are important to the students in their acquisition of English.

3. Student interviews will help you in the final purpose of the needs assessment -- assessing the learners' current level of understanding of spoken English. An assessment of the students' ability to comprehend English is done at this time for your benefit as a teacher, not to test the students' language skills. It is a necessary step in preparing you to meet and interact with the class in a way that they will be able to understand. You need to know what the general level of comprehension of spoken English is among the students in order to prepare your initial presentations to them. It is not necessary that you thoroughly assess your students' level of competence in English before the course begins, but interviewing a few students before the first class meeting will guide your preparations. Talking informally with students about their interests and experiences in language learning will give you an idea of how much you will need to modify your speech initially so that it is understood by the group. See Chapter Six, Program Management and Evaluation, for tips on how you can modify your speech to achieve comprehensibility. Students can also give you information about what they perceive as their needs for English.

These student interviews should not be seen as formal or "testing" situations, but rather as opportunities for informal assessment of individual students which will help you to understand how much of your spoken English the students will comprehend. The students interviews are also useful, particularly in unstructured or informal instructional settings, for you to find out what the students perceive as their needs for English. Your interview questions can probe in depth on this topic. Keep in mind that it is the listening comprehension ability of your students, and not their speaking ability that you are interested in at this point. Assessment of students' other language skills, such as reading and writing, may be accomplished as the course gets under way. See Chapter Three, Developing Language Skills, and Chapter Five: Materials Selection and Development.

### **What to look for**

The materials and activities you select should reflect what students will need to do with the English they learn. As you study subject-matter materials and observe students in their laboratory and classroom interactions, pay special attention to the functions and uses of language in the content area. Many of these can be incorporated into your curriculum. Uses of language include:

- 1) Vocabulary used to identify and describe equipment, tools and machinery.
- 2) Language used to describe procedures, processes, and safety precautions necessary for using equipment, tools, and machinery. Functions for which such language is used include following directions, clarifying/verifying or getting more information, explaining, reporting, giving advice, and requesting help.
- 3) Language used for measurement and mathematics in the specialty skill.
- 4) Language used to evaluate work and to check whether work has been completed properly.

Following the interviews suggested above, you are ready to outline the instructional program that you will provide. In addition to the information from the interviews, you will have collected any subject-matter materials that are available and noted and observed situations in which English is used or will be used by the students.

To summarize:

Needs Assessment interviews cover three sources:

1. Administrators, who will give you information about the institution's requirements of your students.
2. Content area instructors, who will give you information about the materials covered by your students in their specialty studies.
3. Students, who will give you information about how well you will be understood in the classroom and what they perceive as their needs for English.

With this information you should be able to identify the institutional goals the skills to be developed in your ESP class, and the level at which you should pitch your English to communicate best with your students.

### **Chapter three: Developing language skills**

Listening, reading, speaking, and writing -- these are the four basic language skills. Your needs assessment will show you which of these skills should be emphasized in your ESP class. Emphasis will vary from situation to situation, but in many post secondary institutions, students typically need ESP to understand English and will therefore expect priority help in developing their listening and reading skills. However, no skill should be taught in isolation. This section of the Manual describes the language skills, lists objectives for the development of each skill, and gives guidelines and suggestions for classroom activities to give students practice.

#### **Listening**

Listening comprehension, although vital for communication in English, is usually the most neglected of the language skills in English programs. As a native speaker, you have a unique advantage in developing listening comprehension skills in your students. Everything that you say in the classroom can be useful in developing the students' listening abilities.

To be effective, however, your spoken communications with the class must be comprehensible. Language which is not understood is just "noise" and does not lead to student language acquisition. For this reason, it is important for you to gauge your students' level of comprehension and adjust your speech to reflect their understanding. You should spend some time at the beginning of your course to be sure you are understood. Your students may be accustomed to hearing a British accent, for example, and may need time to adjust to yours. Look at your students carefully as you talk to get cues about their comprehension. Check comprehension frequently by asking questions about content which require listening comprehension, or by asking for questions or comments.

The cloze exercise is a good way to check your students' listening comprehension. Give them a short passage with some words deleted. Read the passage aloud twice. If they are unable to fill in the missing words, they are unable to make sense of the passage. More information and examples of cloze exercises can be found on pages 38, 64, and 68 of this Manual. Other ways of using cloze exercises include deleting articles or verbs, for example, if you are working on these forms, to focus students' attention on these language structures.

The tape recorder is a valuable asset to the language teacher. If you have a recorder available, you can tape \_listening exercises in advance to allow yourself the freedom to circulate in the classroom as students complete them. You can also record other native English speakers reading craze or other passages to give the students practice hearing other accents and speakers of the opposite sex.

Give students practice taking notes as they listen. Your students may be used to writing notes down verbatim, as a dictation exercise, and will need practice in listening for main points of



information. Help them to recognize clues to meaning introduced by the speaker. Figure 2 illustrates the types of clues you should bring to your students' attention.

A summary of such clues includes:

- a) Numerical statements, such as "There are two reasons... "
- b) Rhetorical questions.
- c) Introductory summaries: "Let me first explain..."; "The topic which I intend to discuss is interesting because... "
- d) Development of an idea, signalled by statements such as: "Another reason... "; "On the one hand... "; "Therefore... "; "Since... "; "In "; etc.
- e) Transitions, such as "Let us turn our attention to..."; "If these facts are true, then..."; etc.
- f) Chronology of ideas, signalled by "First..."; "The next... "; "Finally..."; etc.
- g) Emphasis of ideas, such as "This is important because..."; "The significant results were... "; "Let me repeat..."; etc.
- h) Summary of ideas, signaled by "In conclusion... "; "As I have shown..."; etc.

(adapted from Richard C. Yorkey, Study Skills for Students of English as a Second Language,. Used by permission of McGraw Hill Book Co.)

Use graphics and visuals whenever possible with listening exercises. Figure 3 shows how a graph can be used to keep students engaged in active listening. Students may also need help in learning to read graphics (maps, charts, etc.) because they may have had little experience with this skill. Listening comprehension activities can help them see how graphic information is read and analyzed.

## **Figure 2. Notetaking Clues**

### **CHOLERA**

Let me tell you, <u>right at the beginning of this talk</u> , I believe that with the correct use of available resources, epidemics of cholera can be controlled.	<ul style="list-style-type: none"> <li>• Introductory Summary</li> </ul>
But before saving how I believe cholera can be controlled. I want to look at <u>two questions</u> : <u>first</u> , Why does cholera occur in certain communities and not others? <u>Second</u> , why, despite all advances in medical science, <b>do people still die from cholera</b> ?	<ul style="list-style-type: none"> <li>• Numerical Statement</li> </ul>
<u>To answer the first question</u> , <b>cholera occurs in conditions</b> where germs spread easily <b>from one person's feces to</b> another person's mouth. These germs are <b>generally</b> spread in food and water, in places where there is no safe water and no latrines. These conditions are found in poor overcrowded communities, where people's resistance to disease is already weakened by malnutrition. <u>In addition</u> , many traditional practices such as the washing of dead bodies and feasting during funerals can help spread epidemics of cholera.	<ul style="list-style-type: none"> <li>• Numerical Statements</li> <li>• Development of Idea</li> </ul>
I now want to turn to the <u>second question</u> . Modern methods of treatment can limit the number of deaths among victims to 1% <b>yet death rates</b> of 30-40% continue to be seen. Why? The basic <b>reason for this high death rate is</b> the insufficiency of medical <b>supplies and trained health</b> workers to help the <b>victims</b> .	<ul style="list-style-type: none"> <li>• Transition</li> <li>• Numerical Statements</li> <li>• Rhetorical question</li> </ul>

<p><u>So what can be done to control cholera?</u> There are three main ways of preventing the disease: <u>1)</u> by improving sanitary facilities, such as latrines, <u>2)</u> by having a safe water supply, and <u>3)</u> by encouraging hygienic preparation of food. All three ways should be taught in health education programs.</p>	<ul style="list-style-type: none"> <li>• Rhetorical question</li> <li>• Numerical Statements</li> </ul>
<p><u>Furthermore</u>, when epidemics do occur, centers to help victims should be quickly set up. Most cholera cases can be treated with oral rehydration therapy - that is, giving those suffering from cholera clean water mixed with sugar and salt. This treatment can be given by a trained health worker without professional education, if proper supplies of water, sugar and salt are available.</p>	<ul style="list-style-type: none"> <li>• Development of idea</li> </ul>
<p><u>To summarize</u>, <u>one important part</u> of cholera control is the providing of better sanitary conditions, supported by health education. And the <u>second important part</u> is the training of health workers in a simple and inexpensive treatment, oral rehydration therapy.</p>	<ul style="list-style-type: none"> <li>• Summary</li> <li>• Numerical Statements</li> <li>• Emphasis of ideas</li> </ul>

Figure 3. From *Fluency Squares* by Philip L Knowles and Ruth A. Sasaki. Copyright © 1981 by Regents Publishing Company, Inc. Reprinted by permission.

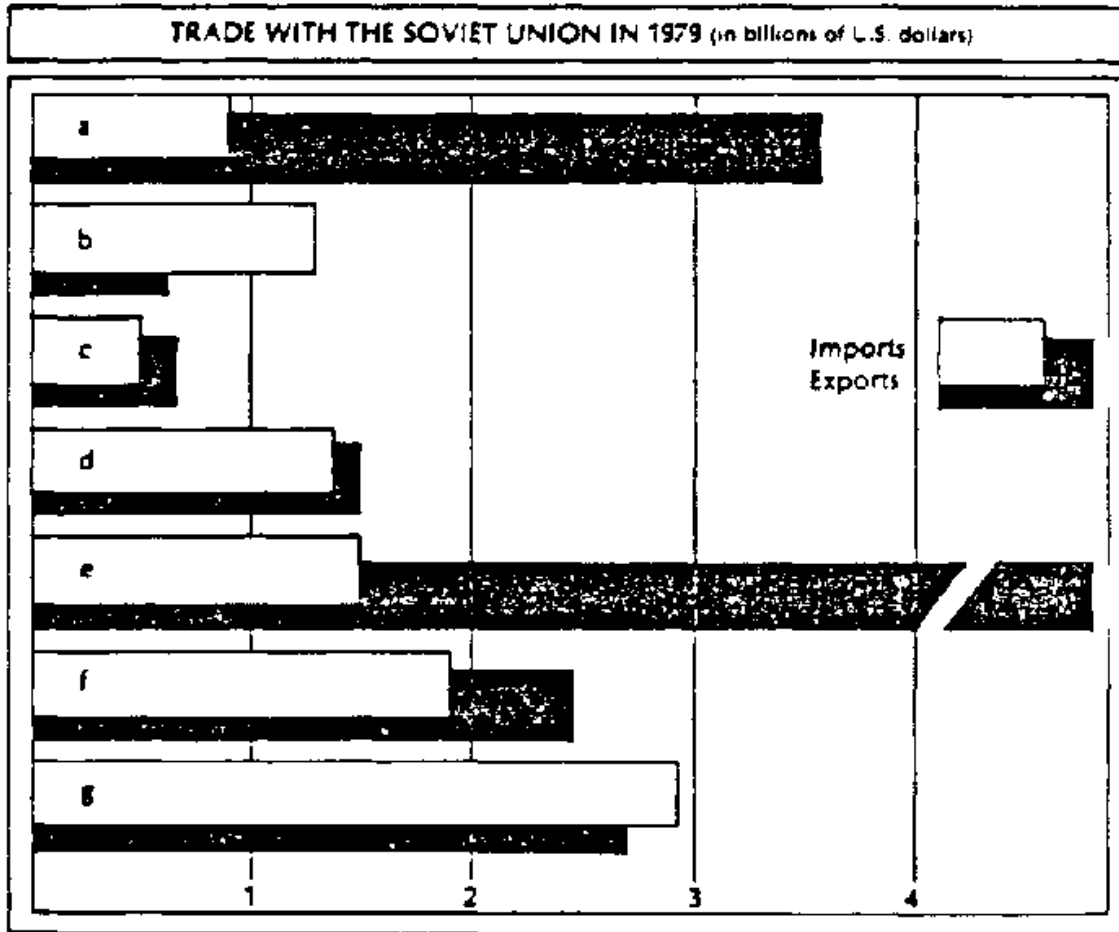

## QUANTITATIVE ENGLISH

### LISTENING TASK

1 Listen carefully. Write the name of each country after the corresponding letter. Use the extra space for notes.

Example Britain's imports from the Soviet Union are more than its exports. Its imports are between one and two billion dollars. (b)

1 The United States' exports to the Soviet Union are about four times as much as its imports. Its imports are less than one billion dollars. (a)

2 West Germany's imports and exports are both between two and three billion dollars. Its imports from the Soviet Union are slightly greater than its exports. (g)

3 Japan sells more to the Soviet Union than it buys. Its exports are slightly more than two billion dollars. (f)

4 Canada's imports from and exports to the Soviet Union were both less than one billion dollars in 1979. (c)

5 France's imports from the Soviet Union were about the same as Britain's. Its exports, however, were about double Britain's. (d)

6 Italy's exports to the Soviet Union were more than four times as great as its imports. It imported more than one billion dollars' worth of goods from the Soviet Union in 1979. (e)

Following are general objectives for the teaching of listening comprehension. General objectives are given in each section of this chapter for the teaching of language skills, but you will need to develop specific objectives for your particular program after you assess student needs and select teaching materials. Guidelines for the development of such objectives are given in Chapter Four, Program Design.

#### Objectives for Developments of Listening Comprehension

1. Students will understand short lectures in the content area when vocabulary is familiar, as demonstrated by their ability to answer questions about the lecture.
2. Students will understand spoken numbers, including percentages, fractions, decimals, and other numerical expressions common to the specialty field, as demonstrated by their ability to write those numbers when they hear them in context.
3. Students will be able to follow instructions given in class regarding assignments and activities, as demonstrated by their correct performance of such instructions.

#### Activities for Teaching Listening:

1. Mini-lectures. Give a short lecture every class meeting to provide students with opportunities to develop note-taking and other listening skills. Make your mini-lectures as contextualized as possible. Demonstrations are particularly effective. Use visual aids and real objects at every opportunity to increase the comprehensibility of your presentation. If possible, go into the laboratory with your students and demonstrate an experiment or process. Organize practical, hands-on activities for student participation. Following your presentation, ask true/false and yes/no questions to give students the opportunity to check their comprehension. You can do this orally, or make it a paper and pencil task and call it a self-evaluation test to allow students to assess their own progress.

If you have sufficient preparation time, it is also useful to construct a cloze exercise in which, following your mini-lecture, you re-read some parts to the students while they follow along and fill in the blanks. This exercise can be checked immediately in class so students receive feedback on their understanding. An example of such an exercise is given in Chapter Four.

2. Reading aloud to your students. They will enjoy listening to you read short passages aloud as they read them silently. They can listen to your intonation patterns and pronunciation and absorb some of the features of native speaker spoken language, which will provide additional clues for the interpretation of complex sentences which might otherwise be beyond the students' competence. If possible, tape recordings of reading assignments can be made available to students out of class.

3. Number recognition. Any technical field requires that students understand spoken numbers. From your initial needs assessment, you will have identified certain math language that students will need to understand in English. Number recognition exercises give them practice doing so. Such exercises develop listening comprehension and numeracy in English and can easily be constructed in advance of each class period.

Ask the students to number a piece of paper from 1 to 10. Then read a sentence which has a number in it. Ask them to write the number they hear. Initially, the numbers you use can be the simple cardinal numbers (differences between sixteen and sixty, for example, often give students problems), but as the course progresses this exercise can become more challenging, as you include numbers in the thousands or millions, monetary expressions, decimals, fractions, percentages, and other specialty uses of numerical expressions which occur in the content area.

Read each sentence twice. Have a student at the blackboard, and as you read the sentence a third time, ask the student to write the number so that the others can check their and get immediate feedback about whether or not they understand. An example of this type of exercise is given in Chapter Four.

4. Dictation exercises. Dictation combines listening and writing practice. When dictating, read the whole sentence at normal speed three times, allowing time for writing between each repetition.

When evaluating dictation, do not focus on spelling as ; primary goal of the exercise. If you think of dictation as a listening comprehension exercise, you can evaluate the product according to whether or not meaning is reflected in what is written. For example, plural endings or past tense endings are necessary for correct interpretation of meaning. Spelling errors which reflect the irregularities of English orthography may not affect meaning.

## **Reading**

Reading is the primary channel through which your students will progress in English after your course is over. A good reading program provides instruction in the skills required at various levels of reading, along with plenty of practice in this skill, which can only be developed through extensive and continual practice. Follow the guidelines in Chapter Five, Materials Selection and Development, for selection of appropriate reading materials.

Two types of skills are needed in reading: simple identification skills, (decoding) and higher level cognitive skills such as analyzing, synthesizing, and predicting. Your reading program should work on two levels to develop both types of skill.

In order to do this, your program should incorporate two types of reading tasks: intensive and extensive. Intensive reading is close analysis of a short passage and can be used to develop

vocabulary, grammar skills, and comprehension. Extensive reading is faster reading of longer passages to develop understanding of writers' organizational strategies, to improve reading speed, and to focus on main ideas.

Fluent reading depends primarily on knowledge of vocabulary and subject matter, and secondarily on knowledge of grammatical structure and familiarity with the ways that writers organize texts in English. Vocabulary development, then, is a vital aspect of reading (and listening) development. Your students will need to develop a good vocabulary in English in order to be efficient readers and listeners. You will probably find that they already know quite a lot of technical vocabulary in English in their fields. You can help them to expand their technical vocabulary and develop the additional vocabulary they need for further study.

Vocabulary should be taught only in context, never in word lists to be memorized with dictionary definitions. Use real objects or pictures whenever possible to introduce new words. The vocabulary you teach should be words which are useful for the students in the situations in which they encounter English. Do not give long lists of words each week; instead, focus on useful words that are present in the reading and listening passages students are working with.

Grammar is best taught in connection with writing (see below), but exercises related to the reading and listening passages the students have worked with can also help them to increase their reading comprehension. Help students focus on grammatical structures which appear in reading texts, such as verb forms, possessives, adjectives and adverbs, and comparative forms.

Higher level cognitive skills necessary for good reading depend on knowledge of the subject matter of the texts and knowledge of the way that information is organized in writing. Your ESP students already bring their knowledge of the subject matter to the reading task, and their backgrounds in their fields will help make the reading materials more comprehensible to them. Students' higher level cognitive skills can be tapped by giving them advance information about the texts they are asked to read, and by teaching them to preview texts before beginning to read. Previewing is a quick reading for general familiarity, in which students a) read the introductory paragraph; b) read the first sentence of each of the body paragraphs; and c) read the entire concluding paragraph. This should take students only a few minutes, and will enhance their reading comprehension.

The SQ3R technique is commonly used to help students get the most from their reading. SQ3R means Survey, Question, Read, Recite, and Review. Students are asked to complete these five activities:

- 1) to survey; looking over headings, reading introductory and concluding paragraphs, and identifying the core ideas of the passage.
- 2) to formulate questions from text headings.
- 3) to make a conscious effort to find the answers in the text as they read.
- 4) Having read the first section, to look away from the book and try to recite the answers to their questions, using their own words and trying to give an example.
- 5) to take notes, and, when they have finished reading, to review their notes.

Training in this procedure will help students to read more efficiently.

Students should receive practice in reading for different purposes, such as finding main ideas, finding specific information, or discovering the author's point of view. Students should have a clear idea of the purpose of their reading before they begin. Background information is very helpful in understanding texts. Students need advance guidelines for approaching each assignment. Knowing the purpose of the assignment will help students get the most from their reading effort.

From the title, for instance, they can be asked to predict what the text is about. It is also helpful to give students some questions to think about as they read. The way they approach the reading task will depend on the purpose for which they are reading.

Use different texts for different reading tasks. Teach the skills of skimming and scanning. Skimming is quick reading to get the general drift of a passage. Students can be asked to skim a text to discover the author's purpose. Scanning is a focused search for specific information. Students can be asked to scan a text to answer a specific question.

Comprehension checks can be built into reading as well as listening exercises. Figure 4 is an example of how a reading exercise can incorporate comprehension checks. Students read part of the passage, then mark statements as "true" or "false" based on what they have read, and then continue reading. You can also teach them to read the questions about the text first, and then read the text itself.

Use long articles as well as short passages. Students need practice with long blocks of text which they read for main ideas as well as intensive work with paragraphs and short passages. Long articles can be read outside of class to provide background for the work that will be done during the class period. You can make long passages more accessible to students by dividing the text into sections and adding appropriate sub-headings.

Train students to recognize patterns of organization of texts. These include the following:

Description: Descriptions include physical descriptions of persons, places, or objects, or descriptions of processes, such as step-by-step explanations of how something is done or directions for doing something.

Example paragraph: Description by enumeration of steps in a process.

In his will, Alfred Nobel left specific instructions as to how the winners of the science awards he endowed are to be selected. First, each year the Swedish Academy of Science (physics and chemistry) and the Caroline Medical Institute (physiology and medicine) solicit nearly two thousand recommendations from past laureates, university professors, and other experts from all over the world. The second step is the review of recommendations received and the selections of preliminary candidates by special committees within the two Swedish institutions. The committee members are specifically instructed that those chosen "shall have conferred the greatest benefit on mankind," and that no consideration be given to the candidates' nationalities. Next, after lengthy investigation and discussion, the final choices are made for each discipline. Finally, telegrams informing them of their awards are sent to the new Nobel laureates about one month prior to the award ceremony.

From Paragraph Development by Martin L. Arnaudet and Mary Ellen Barrett Copyright 1981 by Prentice-Hall, Inc. Used by permission.

**Figure 4. From English in Mechanical Engineering by Eric H. Glendinning. Copyright © 1973 by Oxford University Press, Inc. Reprinted by permission.**

## 1 Engineering Materials

### I READING AND COMPREHENSION

<sup>1</sup>Engineers have to know the best and most economical materials to use. <sup>2</sup>Engineers must also understand the properties of these materials and how they can be worked. <sup>3</sup>There are two kinds of materials used in engineering metals and non-metals. <sup>4</sup>We can divide metals into ferrous and non-ferrous metals. <sup>5</sup>The former contain iron and the latter do not contain iron. <sup>6</sup>Cast iron and steel, which are both alloys, or mixtures of iron and carbon, are the two most important ferrous metals. <sup>7</sup>Steel contains a smaller proportion of carbon than cast iron contains. <sup>8</sup>Certain elements can improve the properties of steel and are therefore added to it. <sup>9</sup>For example, chromium may be included to resist corrosion and tungsten to increase hardness. <sup>10</sup>Aluminum, copper, and the alloys, bronze and brass, are common non-ferrous metals.

Study the following statements carefully and write down whether they are true or not true according to the information expressed above. Then check your answers by referring to solutions at the end of the passage\*.

- (a) Non-metals are used by engineers.
- (b) Cast iron contains more carbon than steel
- (c) Chromium improves the properties of steel.
- (d) Copper contains iron.
- (e) Bronze is an alloy

<sup>11</sup>Plastics and ceramics are non-metals; however, plastics may be machined like metals. <sup>12</sup>Plastics are classified into two types - thermoplastics and thermosets. <sup>13</sup>Thermoplastics can be shaped and reshaped by heat and

- \* The following symbols are used in the solutions
- = equals, means the same as
- ≠ does not equal, mean the same as
- i.e. that is to say
- ∴ Therefore

Comparison and Contrast: In this pattern the main idea is developed through comparison and contrast with other things. Often examples are used to illustrate. Definitions and descriptions are often included in this pattern.

In studying the phenomenon usually referred to as sleep, we are actually dealing with more than one phenomenon. In point of fact, we spend the night alternating between two different types of sleep, each with different brain mechanisms and different purposes. As a person falls asleep, his brain waves develop a slower and less regular pattern than in a waking state. This is called orthodox sleep. In this state the brain is apparently resting. Its blood supply is reduced, and its temperature falls slightly. Breathing and heart rate are regular. The muscles remain slightly tensed. After about an hour in this state, however, the brain waves begin to show a more active pattern again, even though the person is apparently asleep very deeply. This is called paradoxical sleep because it has much in common with being awake. Paradoxical (active) sleep is marked by irregular breathing and heart rate, increased blood supply to the brain, and increased brain temperature. Most of the muscles are relaxed. There are various jerky movements of the body and face, including short bursts of rapid eye movement (REM's), which indicate that we are dreaming. Thus, we spend the night alternating between these two vital "restoration jobs": working on the brain (paradoxical sleep) and working on the body (orthodox sleep.)

From Paragraph Development by Martin L. Arnaudet and Mary Ellen Barrett. Copyright 1981 by Prentice-Hall, Inc. Used by permission.

Other patterns of organization of texts include:

Analysis	In this pattern, a topic is broken down into causes, effects, reasons, methods, purposes-, or other categories that support the main idea
Analogy:	In this pattern the main idea is implied by the use of analogy. This organizing principle is often used to make complex concepts easier to understand by relating them to better known ones.
Definition	The purpose of a text in this pattern is to define, explain, or clarify the meaning of something. It may involve analysis, comparison or contrast, description, or even analogy. Help students to become adept at recognizing implied and explicit definitions.

Do not ask students to read aloud in class to test their comprehension. When reading aloud, the reader focuses on pronunciation, not comprehension. In any case, listening to other students' inaccurate reading is boring and counterproductive. Students should read silently when reading is to be done in class. Students will appreciate hearing you read aloud, however, because listening to native speakers is one way they accustom themselves to the sound patterns of English.

Students often believe they must understand every word in order to read English. In fact, good reading means the ability to process chunks of language larger than single words, so striving for word-for-word recognition will actually slow students down and interfere with their overall comprehension. Encourage them to use the context of the passage to understand it, rather than reaching for the dictionary every time they do not recognize a word. Context clues include use of functional definitions, as in "The scientist used a caliper to measure the thickness of the paper" where the meaning of "caliper" can be inferred from the description of the function of a caliper. Using context clues also includes noting grammatical clues, such as recognizing that a word is an adjective because of its position in the sentence, or noting past tense endings or possessive forms.

Context clues also include understanding the meaning of the other words in the sentence and applying such understanding to infer the meaning of an unknown word or phrase. For example, students can be taught to infer the meaning of the word "drought" in the sentence "Because of the drought, many communities in the Sahel region of Africa are having to leave their homes to search for water."

Be sure to get the most out of any reading passage you assign, using it in various ways so that students work with familiar material that they understand well in doing various types of reading and study skills exercises. Figure 5 shows how a reading passage can be used to develop several different types of exercises. Guidelines for preparing reading comprehension questions are given in Chapter Five, Materials Selection and Development.

#### Objectives for Teaching Reading

1. Students will demonstrate their understanding of authentic material in their content area, including stating the main points of the text and giving the author's point of view.
2. Students will be able to scan a passage quickly to find specific information.
3. Students will use an increasing large vocabulary in the subject area and in general academic language.

#### Activities for Development of Reading Skills

1. Use fill-in-the-blank vocabulary exercises like the one given in Chapter Four, Program Design, to develop students' vocabulary. This type of exercise also doubles as a listening comprehension exercise if you read the sentence aloud and ask students to write in the missing vocabulary word.
2. Vocabulary can also be developed through instruction about prefixes and suffixes that carry meaning in English. These include:



a) prefixes which convey negative meaning, such as un-; in-; non-; a-; dis-; anti-; de-; counter-; contra-; mis-; mal-; under-; over-;. Examples: like/dislike; understand/misunderstand.

b) Noun-agent suffixes such as -er; -or; -ent; -ant; -ist; -ian. Examples: teach/teacher; science/scientist.

c) Verb-forming suffixes such as -ize; -ify; -ate. Examples: organize; specify.

d) Noun-forming suffixes such as -ation; -cation; -tion. Examples: organization, specification.

3. Have students use what they read in order to perform a task. Following is an example of such an activity from the Nucleus series (see Appendix A, Resources):

"In a given system the chances of a component failing after the first five thousand hours are one in a thousand. During the next three thousand hours the chances of failure uniformly decrease until after eight thousand hours the chances are one in two thousand. The failure rate remains constant for the next four thousand hours. It then enters the wearout period and the chances of the component failing in the next three thousand hours increase uniformly to one in eight hundred.

Now draw a graph to plot the changes in failure rate as a percentage. Make the vertical axis the failure rate and the horizontal axis the operating hours."

(From Engineering by T. Dudley--Evans, T. Smart, and J. Wall. Copyright 1978. Used by permission of Longman Group, Ltd.)

4. Exercises can be developed which help make explicit the organizational pattern and/or main idea of the author. The outlining exercise in Chapter Four, Program Design, is an example of this.

5. Encourage students to read extensively by asking them to report on material they have read outside of class which is relevant to the topic under consideration.

6. If time permits, incorporate some time for silent reading into your instructional program.

**Figure 5. From English for Computer Science by Norma D. Mullen and P. Charles Brown. Copyright © 1983 by Oxford University Press, Inc. Reprinted by permission.**

## UNIT 19

### Computer arithmetic

[1] The digital computer is an electronic machine which contains thousands of tiny circuits characterized by the fact that they have only two states: complete and broken. A complete circuit signifies that the electricity is on, whereas a broken circuit signifies that the electricity is *off*. It is through the on and off states that information is transmitted by the computer. Substituting numbers for these states, one can say that 1 is on and 0 is off; this is the number system on which the computer operates. Because there are only two digits in this system, it is termed a binary system with the 0 and 1 being called bits - B from binary and it from digit. They can represent all other numbers the alphabet, and special characters such as \$ and #.

[2] In our everyday arithmetic, we use the decimal system, which is based on ten digits - 0, 1, 2, 3, 4, 5, 6, 7, 8, and 9. In the decimal system, multiplication by ten would yield the following results:

$$10 = (10^0 \times 0) + (10^1 \times 1)$$

$$100 = (10^0 \times 0) + (10^1 \times 0) + (10^2 \times 1)$$

$$1000 = (10^0 \times 0) + (10^1 \times 0) + (10^2 \times 1) + (10^3 \times 1)$$

In tabulating this, we notice that we multiply by 10 each time we move a number one column to the left, that is, we increase the base number 10 by the power 1.

$(10^3)$	$(10^2)$	$(10^1)$	$(10^0)$	
1000	100	10	1	
			1	(1)
		1	0	(10)
	1	0	0	(100)
1	0	0	0	(1000)

Therefore, 652 in the decimal system is equal to  $2 + 50 + 600$ :

100	10	1	
		2	(1 x 2)
	5	0	(10 x 5)
6	0	0	(100 x 6)

[3] Since the binary system is based on two digits, 0 and 1, we multiply by 2 instead of by 10 each time we move a number one column to the left. So to convert binary to decimal, we use the base number 2 with sequentially increasing powers.

$(2^3)$	$(2^2)$	$(2^1)$	$(2^0)$
8	4	2	2

As an example, the decimal number 1 is 0001 in binary.

8	4	2	1	(decimal)
0	0	0	1	(1 X 1)

The decimal number 2 is equal to  $1 \times 2$  plus  $0 \times 1$  or 0010 in binary.

8	4	2	1	
0	0	1	0	(0 x 1) plus (1 x 2)

The decimal number 3 is equal to  $1 \times 1$  plus  $1 \times 2$  or 0011 in binary.

8	4	2	1
0	0	1	1

Let us tabulate the decimal numbers 0 to 15 in the binary system.

$(2^3)$	$(2^2)$	$(2^1)$	$(2^0)$	
8.	4	2	1	
0	0	0	0	(0)
0	0	0	1	(1)
0	0	1	0	(2)
0	0	1	1	(3)
0	1	0	0	(4)
0	1	0	1	(5)

0	1	1	0	(6)
0	1	1	1	(7)
1	0	0	0	(8)
1	0	0	1	(9)
1	0	1	0	(10)
1	0	1	1	(11)
1	1	0	0	(12)
1	1	0	1	(13)
1	1	1	0	(14)
1	1	1	1	(15)

[4] The binary system is very tedious for humans, especially in the handling of long numbers, and this increases the possibility of committing errors. To overcome this limitation, two number systems were developed which are used as a form of shorthand in reading groups of four binary digits. These are the octal system with a base of 8, and the hexadecimal system with a base of 16. CDC computers use the octal system, whereas IBM computers use the hexadecimal.

[5] The table above shows that four binary digits may be arranged into 16 different combinations ranging from 0000 to 1111. This forms the basis of the hexadecimal system. To represent these binary combinations, the system uses the digits 0 to 9 and 6 letters of the alphabet. A, B, C, D, E, and F. Following is a table that shows the relationship between the binary, the octal, the hexadecimal, and the decimal systems.

Decimal	Hexadecimal	Octal	Binary
0	0	0	0000
1	1	1	000 1
2	2	2	0010
3	3	3	0011
4	4	4	0100
5	5	5	0101
6	6	6	01 10
7	7	7	0111
8	8	10	1000
9	9	11	1001
10	A	12	1010
11	B	13	1011
12	C	14	1 100
13	D	15	1101
14	E	16	1110
15	F	17	1111

[6] On some computers, addition is the only arithmetic operation possible. The remaining arithmetic operations are based on the operation of addition (+): subtraction (-) can be thought of as the addition of negative numbers, multiplication (x) is repeated addition; division (/) is repeated subtraction. How do we add in the binary system? There are four basic rules of addition which we must remember:

- 1 + 0 = 1
- 0 + 1 = 1
- 0 + 0 = 0
- 1 + 1 = 0 and carry 1 or 10 (read from the right to the left as zero - one).

Here is an example:

Binary	Decimal
--------	---------

1110	14
1000	8
10110	22

## Exercises

### 1 Main idea

Which statement best expresses the main idea of the text? Why did you eliminate the other choices?

1. There are four different number systems.
2. Most arithmetic operations can be analysed in terms of addition.
3. Computer arithmetic is based on 0 and 1.

### 2 Understanding the passage

Decide whether the following statements are true or false (T/F) by referring to the information in the text. Then make the necessary changes so that the false statements become true.

T	F	
		1. The digital computer uses the decimal number system.
		2. In the decimal system, the 0 is called a bit.
		3. The binary system has only two digits.
		4. In binary arithmetic $1 + 1 = 0$ .
		5. Unlike IBM computers, CDC computer arithmetic is based on 8 digits.
		6. The hexadecimal system is based on 16 numbers.
		7. To subtract a number really means to add a negative number.
		8. The computer transmits information through the principle of connected or broken electrical circuits.
		9. The S sign cannot be represented in the binary system because it is not a number.
		10. The hexadecimal system is an economical way of representing the binary system.

### 3 Locating information

Find the passages in the text where the following ideas are expressed. Give the line references.

- .....1. To do calculations using the binary system is laborious work.
- .....2. The computer gets information by means of electric circuits which are either on or off.
- .....3. In binary,  $1 + 1$  equals 0 and 1 is carried to the next column.
- .....4. Both numbers and letters are used in the hexadecimal system.
- .....5. The binary system has two digits only.

### 4 Contextual reference

Look back at the text and find out what the words **in bold** typeface refer to.

1. that they, have only two states	(1.2).....
2. it is termed a binary system	(1.8).....
3. They can represent all other numbers	(1.10).....
4. which is based on ten digits	(1.12).....
5. this increases the possibility	(1.67).....
6. These are the octal	(1.70).....
7. This forms the basis	(1.74).....
8. that shows the relationship	(1.77).....

## 5. Understanding words

Refer back to the text and find synonyms for the following words

1. means	(1.3) .....
2. replace	(1.6) .....
3. conditions	(1.6) .....
4. give	(1.14) .....
5. uninteresting	(1.66) .....

Now refer back to the text and find antonyms for the following words.

6. incomplete	(1.3) .....
7. completed circuit	(1.4) .....
8. decrease	(1.9) .....
9. impossibility	(1.67) .....
10. the same	(1.74) .....

## 6 Word forms

1. characterize, characteristic, characteristically, characterized, character
  - a. My daisy wheel printer can print 132 ..... per line
  - b. Daisy wheel printers are ..... by having a superb print quality.
  - c. Can you describe the most important ..... of the computer?
  - d. The 0 and 1 in computer arithmetic represent the alphabet, all numbers, and special ..... such as \$ and £.
2. substitution, substituting, substituted, substitute
  - a. The 0 and 1 in computer arithmetic are ..... for the two states of electricity, i.e. off and on.
  - b. There is no..... for the speed at which a computer performs arithmetic operations.
3. conversion, convert, converted, converter
  - a. Canada has ..... from the British to the metric system. Now centimetres are used instead of inches.
  - b. .... from an old computer system to a new one can be time-consuming and complicated.
  - c. Before the computer can do the necessary computations for a problem, the number should be ..... to machine code.
4. combination, combine, combined, combining
  - a. To represent the 16 different ..... of four binary digits, the hexadecimal system uses the digits 0 to 9 and A, B, C, D, E and F.
  - b. Today's microcomputers are almost as powerful as yesterday's minis, mainly because of man's creativity ..... with the advancement in chip technology.
5. basis, base, based, basic

- a. The binary system is ..... on two digits: 0 and 1.
- b. The decimal system uses 10 as a..... whereas the hexadecimal system uses 16.
- c. Data ..... management involves structuring and organizing data so as to make them useful and available to more than one particular user.
- d. Flowcharting is a ..... step in programming.

## 7 Content review

Write the appropriate words for the following definitions.

1. a number system based on 10.....
2. a number system based on 8.....
3. a number system based on 16.....
4. a number system fused on 2 .....
5. 0 and 1 when they are the only digits of a number system .....

## Writing/Grammar

Although your students will probably place great emphasis on learning grammar, you should assure them that grammar is not the most important aspect of language learning. This is easily demonstrated by reference to the person who knows many grammar rules and yet cannot understand or express anything in the spoken language. Students whose language courses have always focused exclusively on grammar may urge you to spend lots of class time explaining various points of English grammar and structure. Such explanation is actually teaching English linguistics, and there is controversy in the field of EFL teaching regarding the real value of such instruction for language learners. Students may have a false sense that they are learning English, when, in fact, they are learning about English, but making little progress toward comprehending and being able to use the language in the contexts for which they need it.

Understanding and communicating in English is within the students' reach even if they don't understand the fine points of grammar. The ability to function in English is not directly linked to accuracy of grammatical use or pronunciation. Students need to be encouraged to use English even if they make mistakes. The main purpose of language use, after all, is communication.

Some instruction in grammar is necessary, however. Especially in written work, learning grammar rules can help students to recognize and correct their errors. In preparing to teach grammar, be sure you have a good understanding of the structures that you want to teach, so that your presentation is clear. It is also important that your students be able to use the grammar they practice. One way to ensure that students can make effective use of what they learn is to teach grammar in conjunction with writing, the skill in which it can best be practiced. In speaking, we do not usually have the time to remember and apply rules of grammar, but in writing we have ample opportunity to monitor our usage. It is in writing that grammar instruction is most useful. The grammatical forms which are most useful and most learnable are those which control sentence--level functions such as question form, negation, relative clause formation and other structures involved in subordination and coordination. These features are more important than correct usage of articles or other non-sentence-level features. Focusing on paragraph features such as, tense continuity across clauses, parallel structure, and connectors, will help students in reading comprehension as well. (See section on READING, above, for more ideas on teaching grammar with reading.)

Development of writing ability takes lots of practice. Start with simple, structured exercises and allow students to develop confidence as writers before you give them longer free writing tasks. As in other skills, development of writing can be enhanced through the use of appropriate visuals.

See Figure 6 for an example of how a text uses a diagram of the carbon cycle to guide students in writing true sentences. Students need only choose the correct combination of elements to write the sentences. Another such exercise is shown in Figure 7. Here the students write statements which establish relationships among animals based on information from a diagram.

**Figure 6. From *General Science* by Rates and Evans. Nucleus: English for Science and technology Series. Copyright © 1976 by Longman Group Ltd. Reprinted by permission**

7. Read this passage and look at the diagram:

**The carbon cycle**

The life of plants and animals depends on chemical substances containing carbon atoms. Plants obtain carbon from the very small amounts of carbon dioxide in the atmosphere. This atmospheric  $\text{CO}_2$  is continually absorbed and given off (released) in the carbon cycle:

Diagram

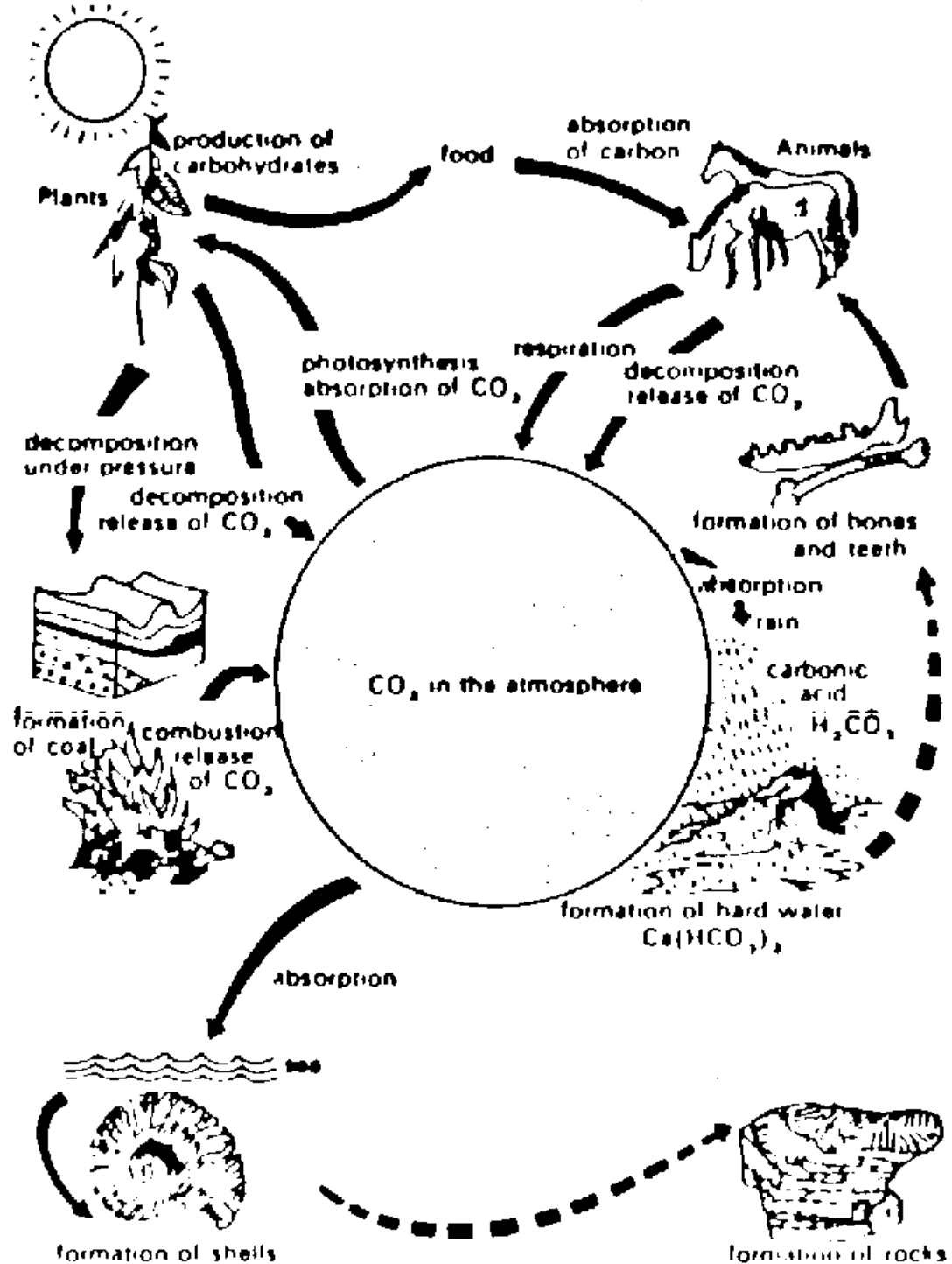

Look at these:

- (A = cause, B = result)
- A result in B
- B results from A.
- As a result of A, B occurs



As a result of	eating plants photosynthesis combustion of coal, decomposition of dead plants	carbon dioxide is given off. Carbohydrates are produced by plants animals absorb carbon.
Decomposition of plants under pressure		respiration photosynthesis
Release of CO <sub>2</sub> into the atmosphere	results in	the formation of teeth and bones in animals
Decomposition of dead animals		the formation of rocks the formation of coal
Formation of hard water	results from	the release of CO <sub>2</sub> into the atmosphere.
Absorption of CO <sub>2</sub> by the sea	leads to	the formation of shells
Production of carbohydrates		the combinations of rain and CO <sub>2</sub> in the atmosphere
Formation of carbonic acid		
Formation of shells		

Writing assignments should be carefully structured. They should also be practiced and reviewed often and used as a basis for more complex writing assignments. Paragraph writing exercises can be based on models which the students first complete, and then expand or build on. An example of this is given in [Figure 8](#). Students first complete a paragraph based on a diagram, and then use another diagram to write a paragraph in similar style.

If development of skill in writing longer compositions is a goal of your writing program, work gradually toward this goal. Compositions are very time-consuming to correct and should be limited in length and scope. Following are the structural errors most often found in student compositions:

1. Subject-verb agreement
2. Articles
3. Word order problems: adverbs, *wh*-clauses.
4. Present perfect tense
5. Verb + Verb-ing (gerunds) vs. Verb + to + Verb (infinitive)
6. Passive Voice
7. Spelling
8. Punctuation

(From [Guide to Language and Study Skills for College Students of English as Second Language](#) by A.V. Martin et al.)

"Dialogue journals" have recently become quite popular as a way for teachers to communicate with students individually in writing without spending massive amounts of time in correction. The students are encouraged to keep a notebook, a dialogue journal, in which they write anything they want. The teacher collects the journals at regularly scheduled intervals, reads them, and writes notes or comments to the student; hence, a "dialogue" is created. Error correction can be done through teacher entries, where the correct forms are modeled. Dialogue journals are an effective way for you to get to know students individually if you have large classes.

If students write during class time, the teacher can circulate among the students, monitor their progress, and offer suggestions. This can be a useful activity.

**Figure 7.** From [Biology](#), by Adamson and Bates. (Nucleus: English for Science and Technology Series). Copyright © 1977 by Longman Group Ltd. Reprinted by permission.

6. Look at this diagram:

Diagram

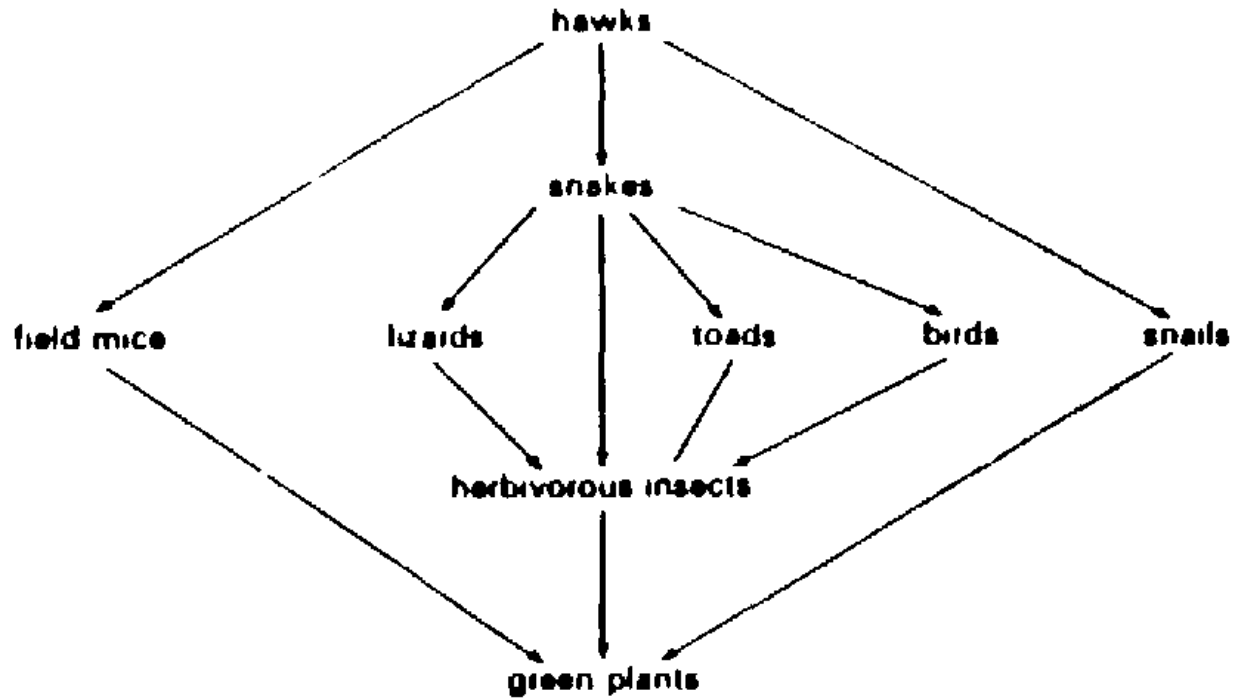

Look at these examples:

*Possibility:* Green plants may be eaten by herbivorous insects or they may be eaten by field mice. They may also be eaten by snails.

*Probability:* Field mice are likely to feed on green plants.,

Now make other statements about possible and probable feeding habits of the following:

- snakes/hawks
- field mice/snakes/hawks
- snails/green plants
- herbivorous insects/toads/snakes/birds/lizards
- lizards/herbivorous insects
- snails/snakes

**Figure 8.** From English in Basic Medical Science by Joan Maclean. Copyright © 1975 by Oxford University Press. Inc. Reprinted by permission.

### III INFORMATION TRANSFER

1. Look at the following diagram. Write out the paragraph and complete it with reference to the diagram.

*Osmosis in A capillary (systemic circuit)*

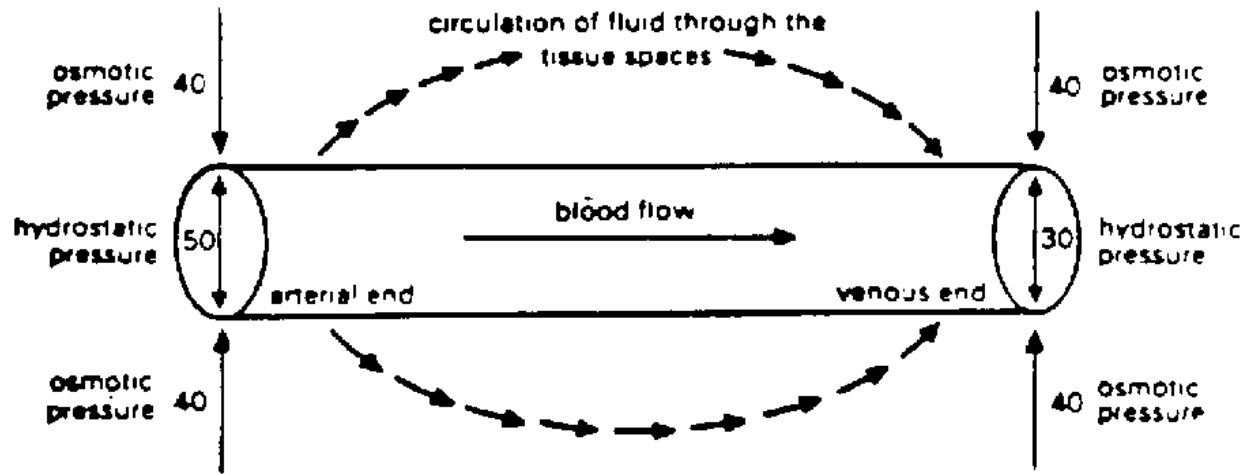

As the blood ..... from the arterial ..... to the ..... of the ..... the ..... pressure decreases. In this example, it .....from ..... mm of mercury to ..... mm. The ..... however, remains constant at ..... mm. At the arterial end, the ..... exceeds the ..... by ..... mm, and so fluid passes out of the capillary into the ..... At the ..... end, the ..... is less than the ..... by .....mm, and so approximately the same amount of .....passes out of the ..... into the ..... Thus the difference in pressures causes the ..... through the .....

#### Objectives for the Development of Writing Skills

1. Students will be able to summarize material which they have read.
2. Students will be able to take notes on lectures or readings.
3. Students will be able to compose coherent paragraphs on familiar topics.
4. Students will be able to write short letters in standard format.
5. Students will be able to write for a variety of purposes, depending on the needs of their specialty area.

#### Activities for Developing Writing Skills

1. Copying exercises are helpful for beginning learners, especially if their native language uses a writing system different from English.
2. Writing exercises include dictation and completion of cloze or fill-in-the-blank exercises. Completion of cloze exercises forces students to hypothesize and to recognize relationships between sentences.
3. Sentence-combining exercises require students to combine short sentences into longer ones. This gives them practice with coordination and subordination without requiring the composition of coherent prose passages.

For example, given the sentences:

Wheat is subsidized by the government.  
The subsidy is paid for local wheat.  
The subsidy is also paid for imported wheat.  
The purpose of the subsidy is to keep bread prices low.

Students can form the sentence:

Both local and imported wheat are subsidized by the government in order to keep bread prices low.

4. Re-ordering jumbled sentences helps students build understanding of paragraph structure.
5. Note-taking exercises give students practice recording information. Guide them in developing good note-taking style. Teach them that when they take notes they should include content words, important diagrams, correct figures (such as percentages, quantities), transitional expressions, and appropriate abbreviations and symbols. See page 12 for more tips on teaching note-taking skills.
6. Outlining exercises for reading, shown in Chapter Four, Program Design, help students to see the organizational structure of material they read. In writing, outlining exercises can prepare the students to write by forcing them to make their own organizational patterns explicit. Ask students to write a sentence giving the main thesis of their composition, and then to outline the main points they will develop in support of the thesis.
7. Summarizing exercises can be combined with reading or study skills assignments. Such exercises can also be used to develop skills in paraphrasing and to caution students against plagiarism. For example, students can be asked to read and summarize information in preparation for writing a research paper. The teacher can evaluate the summary in terms of how well the students express the information in the article in their own words.
8. Writing descriptions can include descriptions of substances, places, and objects. At more advanced levels this might include interpretations of illustrations, graphs, and charts.
9. Writing descriptions of processes, including writing instructions or "how to" exercises as well as descriptions of how things happen over time. See example, [Figure 9](#).
10. Writing definitions. See example, [Figure 10](#).

**Figure 9. From *Reading and Thinking in English: Discovering Discourse* by John Moore et al. Copyright © 1979 by the British Council Reprinted by permission.**

### Activity 7

Study the following about radio communication and label the diagram using words from the list given.

Diagram

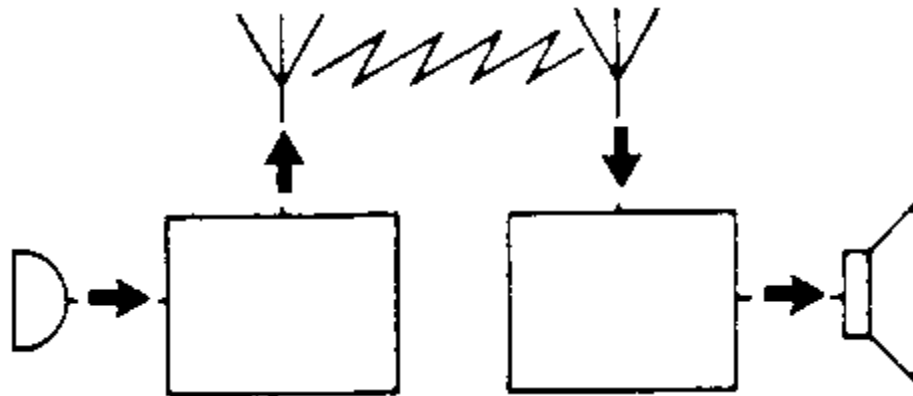

Microphone  
Receiving aerial  
Transmitter  
Loudspeaker  
Receiver  
Transmitting aerial

A radio transmitter generates radio-frequency waves.  
A transmitting aerial radiates the waves into space.  
A receiving aerial intercepts a portion of the radiated waves.  
The receiving aerial often consists of a piece of wire or a loop.  
The wire conducts small electrical signals to the radio receiver.  
The radio receiver selects and amplifies the signals.  
The radio receiver contains a detector.  
Audio signals are sent out by the detector.  
An amplifier strengthens the audio signals.  
A loudspeaker converts the amplified audio signal into sound waves.

Now complete the following description of the whole process. Make information previously mentioned the theme of each sentence.

The first element in radio communication is a radio transmitter which..... into space by a..... is intercepted..... a piece of wire or a loop.... conducts small electrical signals to the radio receiver.... by the.... The radio receiver .....The detector.....are strengthened .....by a loudspeaker into.....

**Figure 10.** From **English in Mechanical Engineering** by Eric H. Glendinning. Copyright © 1973 by Oxford University Press, Inc. Reprinted by permission.

**EXERCISE B** *Making definition*

Study the following diagram:

Diagram

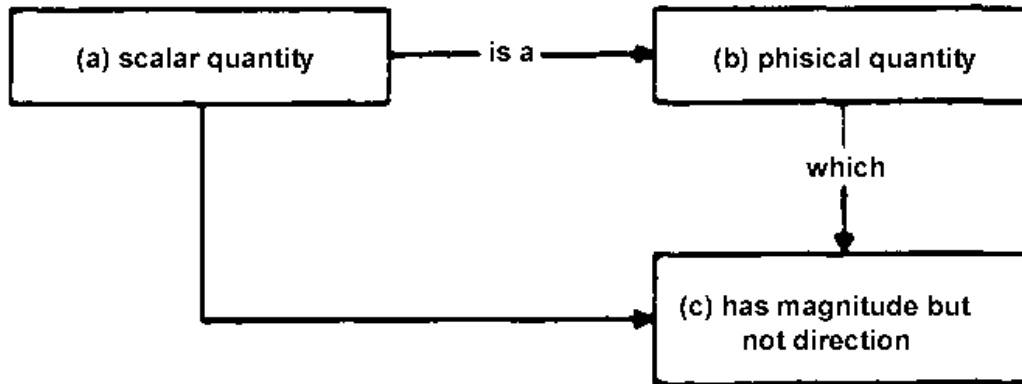

We can make a classifying sentence about a scalar quantity by joining (a) and (b):

A scalar quantity is a physical quantity.

We can then expand the sentence by including (c):

A scalar quantity is a physical quantity which has magnitude but Dot direction

The expanded sentence defines a scalar quantity. It is a *definition*. Now write as many definitions as you can using the following table.

*English in Mechanical Engineering*

a	b	c
a vector quantity		can extend a body
a load		has magnitude and direction
a tensile force	straight line	represents a vector quantity
a linear dimension	force	is a product of basic units
a vector	unit	can be measured in a straight line
a compressive force	dimension	can stretch compress a body
a derived unit	physical quantity	can compress a body
friction		opposes motion

**Speaking**

Your needs assessment will determine whether the development of speaking skill is a goal in your ESP class. For many ESP situations, development of speaking skills may be beyond the scope of what it is possible for you to provide. To provide every student with practice in speaking is an inefficient use of classroom time. Discussion groups are notoriously difficult to manage. Students rarely listen to each other talk and "conversation" degenerates into one student after another saying unrelated things. Aggressive students usually take and hold the floor, and it becomes impossible to give everyone the same amount of practice. Even if everyone did get the same amount of practice, in the typical class of 50 students and two hours of class time, each student could not possibly get more than two minutes of practice!

You and your students should not despair, however, because although in your situation the direct teaching of speaking may not be practical, studies have shown that increased listening comprehension leads to increased ability to speak. You can assure the students that the

exercises they are doing to increase their listening comprehension will make them better able to hold conversations with native speakers of English.

If teaching speaking skills is one of your objectives; for example, in an ESP class in English for Tourism, you will need to select activities that reflect the real functions for which your students will use English.

Asking the class to repeat in unison is not teaching speaking. They will not necessarily repeat correctly, you cannot correct their errors, and repetition may only reinforce their mistakes. Memorizing and repeating dialogues will also not improve the speaking skill. Speaking is a communication activity and improves only with practice in communication. Therefore you are better off using class time for activities which will increase overall language proficiency and ability to comprehend spoken English.

Give students practice in conversation management. Teach them greetings and closings, and replies to greetings and closings. Teach them how to introduce themselves and others. Teach them forms they can use when they do not understand, such as "Pardon me. What was that again?" or "What does \_\_\_\_\_mean?" or "Please speak more slowly. "

Pronunciation is often overstressed in language teaching and should play a restricted role in your class. Perfect, or native like, pronunciation need not be a goal. English is now a world language and different pronunciations are standard throughout the world. Learners also need to show themselves to be learners lengthy drills to achieve perfect pronunciation of a few words is not only time-consuming, but may also mislead native speakers into thinking that the student is more fluent than he or she actually is, leading to breakdowns in communication.

Role playing is an effective way to stimulate conversation in the classroom. You can use flowcharts to outline a situation which you want to use as a base for developing your students' speaking skills. You may want to select a small group of students to demonstrate this method until the whole class understands the procedure, Once this is done, you can divide the class into groups, vary the flowcharts for each group, and then ask each group to act out their situation for the rest of the class.

The steps for this exercise are as follows:

1. Choose a situation. This could be based on a text your students are studying, either with you or in another class. For example, students of hotel management may be studying public relations, and you could devise a flowchart which requires students to exercise their public relations skills in English.
2. Teach the required vocabulary, language functions and grammar. (See suggestions on pages 16 and 24 for teaching vocabulary.) You could then ask students to use these same vocabulary items, functions and grammar points in their role play. This would provide you with a focus when you are noting errors. Concentrate on correct use of the selected items, but otherwise ignore errors, except, of course, those that lead to major breakdowns in communication.
3. Design a flowchart similar to the one in [Figure 11](#). The kinds of exchanges this flowchart might generate include:

**Receptionist:** Good morning sir (madam). Can I help you?

**Guest:** Yes. My name is Mr\_\_\_\_\_. . I have reservations for two nights.

**Receptionist:** Let me see. I'm afraid I can't see your name on my list. Are you sure the reservations were made?

**Guest:** Yes, of course I'm sure. This is very annoying. These reservations were made weeks ago.

**Receptionist:** I'm sorry, sir. Let me check again.

**Guest:** This is too much. I would like to talk to the manager. (Etc.)

Figure 11. Flow Chart for Role Playing Activity.

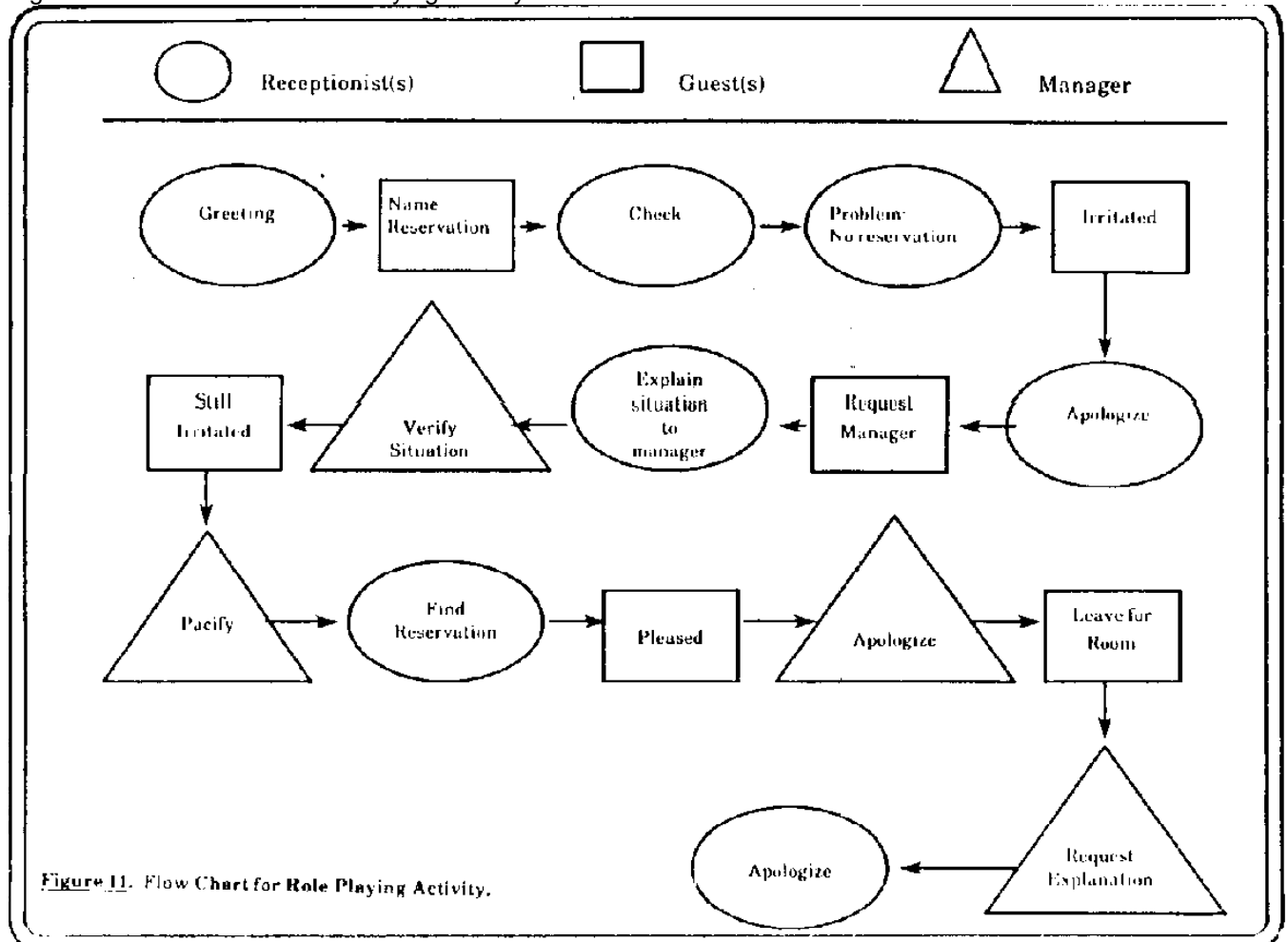

Other situations for tourism and hotel management ESP could include tracing lost luggage, renting a car, discussing a hotel bill, visiting a historical monument, etc.

#### Objectives for the Development of Speaking Skills

1. Students will be able to carry on a short conversation on a familiar topic.
2. Students will be able to give a short oral presentation that they have prepared in advance, fluently and with few errors.
3. Students will be able to ask for information, using appropriate language forms.
4. Students will be able to answer a complaint or apologize appropriately.

#### Activities for Developing Speaking Skills



1. Debating. You can divide students into teams and have them present opposing sides of an issue.
2. Interpreting pictures or explaining diagrams.
3. Giving directions; for example, looking at a map and explaining how a person would get from point A to point B.

### **Study skills**

Your students will probably have had little practice in study skills that we take for granted. They will need instruction in how to use English dictionaries, grammars, and other reference books. They will also need practice in basic library skills such as using an index or bibliography. In order to do effective research, they will need to know how to look at a book and determine the author, publisher, date and place of publication. You should plan to devote some part of each instructional unit to development of these skills.

The students will need practice using good English language dictionaries, not just bilingual dictionaries which translate from their language into English. Bilingual dictionaries seldom contain the technical terms needed for subject-area study.

If your institution has a library with English-language materials, ask the librarians to give your students an orientation session to show them where English-language materials relevant to their subject area are kept. They can also point out bibliographies and indexes which are available for your students' use. You can assign follow-up activities asking students to take notes, paraphrase, or compile bibliographies on topics in their fields.

If no library is available to you, you will be more limited in the skills you can teach. You can still show students how to get the most from the texts that are available to them, however, by giving them practice using the index or bibliography of a text that is available.

Give students practice taking notes and writing summaries. Use these activities to introduce the notion of plagiarism and ensure that they are aware of academic protocols regarding quotation and use of paraphrased material. Introduce conventions for citation and footnotes, and preparation of bibliographies.

### Objectives for Development of Study Skills

1. Students will be able to identify the parts of a book, including title page, table of contents, index, glossary, etc.
2. Students will be able to use dictionaries for information about pronunciation and syllable division, to identify the way words are commonly used in sentences (parts of speech), to find correct meanings, and to determine whether the word is British or American, formal or informal.
3. Students will be able to use indexes, including being able to use alternate search words when the topic they have in mind is not listed.
4. Students will be able to use bibliographies, including being able to identify titles which might provide additional information on their topic of research.
5. Students will develop note-taking skills, including outlining and paraphrasing.
6. Students will be able to summarize information they have heard or read.

### Activities for Developing Study Skills.

1. The efficient use of a dictionary should be a focus of your work on study skills. One technique for learning frequently used words is for students to make a small dot beside a word every time they look it up in the dictionary. If students find certain words accumulate a number of dots, they should make a list of those words for more intensive study.
2. Other activities which develop dictionary skills include:
  - a) Alphabetizing exercises. Especially if the students native language does not use the Roman alphabet, they will need practice putting words in alphabetical order, particularly words that begin with the same letter or letters. This skill is necessary for any library work and in order to efficiently consult dictionaries, encyclopedias, and other reference works. It is also necessary for office work, hotel management, tourism, and other fields.
  - b) Syllable division exercises. Students will need to use the dictionary to find syllable divisions in order to correctly divide words when writing.
  - c) Guide word exercises. Students can practice using guide words to locate words more quickly.
  - d) Pronunciation key exercises. Dictionaries use common words, called key words, to illustrate the pronunciation of the various symbols used by the publisher to show how words are pronounced. See the illustration of this in Figure 12. Students can be taught to use these symbols, along with stress markings, to get full use of their dictionaries.
  - e) Definition identification exercises. Students should practice identifying which definition is most appropriate when several are given for the same word.
3. Encyclopedia exercises. If encyclopedias are available in the library, students should be shown how they are organized and instructed in the use of the encyclopedia's index. They can be asked to locate and summarize or paraphrase information.
4. Yearbooks. Reference books such as the World Almanac and Who's Who, and other yearbooks can be used to get current information on a wide variety of topics.
5. Atlases. Students can use atlases to get many kinds of information; for example, about geographical features, population distribution, major resources, and climate.
6. Bibliographies. Students can be asked to use bibliographies to identify other sources of information about topics of interest to them.
7. Students' abilities to read and understand published research in their fields of study may depend on their knowledge of such research vocabulary as Hypothesis, Experimental Design, Data Collection and Compilation, Interpretation of Results, and Evaluation. It may be helpful to give students an example of a research paper which uses an experimental research process and discuss together the components of the research design.

**Figure 12. From Longman Dictionary of American English: A Dictionary For Learners of English. Copyright 1983 by Longman Inc. Reprinted by permission.**

#### **Pronunciation table**

<b>VOWELS</b>	
<b>Symbol</b>	<b>Key Word</b>
i <sup>y</sup>	beat
1	bit

e <sup>y</sup>	bay
ɛ	bit
æ	bat
a	box, car
o	bought, horse
o <sup>w</sup>	bone
u	book
u <sup>w</sup>	boot
ʌ	but
	banana, sister
ai	by
au	bound
oi	boy
?	burn
?	beer
?	bare
?	tour

/t/ means that the /t/ sound is said as a voiced sound (like a quick English /d/)

/?/ means that /?/ may or may not be used

/\*/ shows main stress

/,/' shows secondary stress

/\*/ shows stress shift

CONSONANTS	
Symbol	Key Word
p	pan
b	ban
t	tip
d	dip
k	cap
g	gap
tʃ	church
dʒ	judge
f	fan
v	van
θ	thing
ð	then
s	sip
z	zip
f	ship
ʒ	measure.
h	hot
m	sum
n	sun
ŋ	sung
w	wet
hw	what
l	lot
r	rot
y	yet

## Chapter four: Program design

This Chapter gives guidelines for the design of an ESP program. It takes you through the process of setting goals, designing units, and preparing lesson plans. The steps for designing a program are shown in [Figure 13](#).

Figure 13. steps in ESP Program Design.

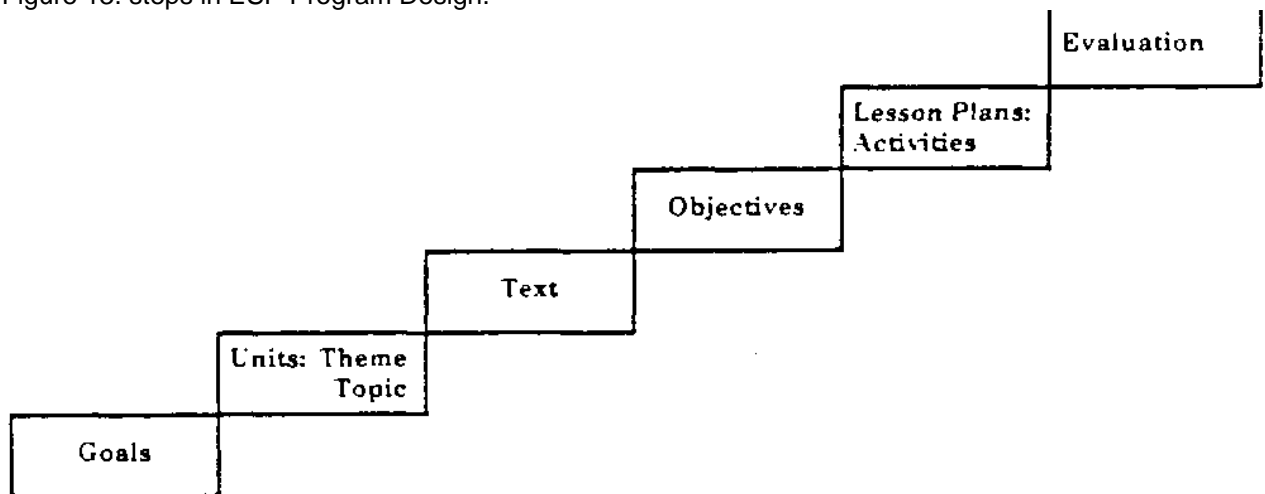

### Setting goals

Setting goals is the first step in the development of your instructional program. These goals will reflect what you intend for the students to be able to do with English at the end of your course of instruction. Identify relevant, concrete, and motivating goals appropriate for your students.

Setting goals for learning will become easier as you become more familiar with the institution and your students. Initially, you should recognize that your goals will be limited. Your students will not be able to achieve complete fluency in English in a semester- or year-long program. Your task is to specify just what goals are reasonable. For most year-long Peace Corps ESP programs, the following are reasonable goals:

- Students will be able to read and comprehend textbooks and research articles in their fields.
- Students will be able to understand short lectures in English in their technical fields.
- Students will be able to write short summaries of material they have read.
- Students will be able to locate resources for further information in their specialty area.
- Students will be able to ask questions to get information or clarify points.
- Students will be able to give short oral reports.

These goals encompass the skills needed for academic study in an ESP situation where students' needs for English are limited to reading and attending lectures in English. You may need to set different goals for students in other contexts. In formulating your goals, you will need to set priorities for the development of language skills, and in doing so it is useful to bear in mind that reception precedes production in language learning. In other words, students cannot learn to say or write something which they cannot understand. A manageable initial objective, then, is to improve the students' receptive competence; that is, their listening comprehension and reading skills. Listening comprehension is a must for the student who wishes to attend presentations or training in English and is a prerequisite for achieving oral fluency. A good speaker must first of all be a good listener. As a native speaker, you are in an excellent position to focus on developing

students' comprehension of spoken English, which will give them the basis they need to develop skills in speaking and conversational interaction.

Development of conversational skills may be an unrealistic goal for most Peace Corps ESP courses, where large class size and varying levels of English proficiency make it impossible to provide each student with adequate practice in speaking. It may also be an unnecessary goal, since students' primary need for English will most likely be to gain access to information or training in English, tasks which rely less on speaking than on reading and listening. In you are teaching ESP for tourism, on the other hand, you may need to put a high priority focus on developing listening and speaking skills.

Having set long-term goals, you are ready to select materials and classroom exercises that lead to development of appropriate skills. The range of English abilities in your classroom will undoubtedly be large. The task you face is to design a program which challenges the more advanced students without intimidating and discouraging those whose English skills may be weak. You may also face the added challenge of large classes, few materials, and little equipment. The suggestions given here are designed to overcome those obstacles.

### **Designing units**

It is impractical to think of designing your entire semester or year-long ESP program in advance. It is impossible, at the beginning of the course, for you to know how quickly students will progress. Instead, try to outline one or two units of instruction before classes begin and then be flexible in adapting or modifying your program as you get to know the students better. As you become better acquainted with the resources of the institution and the backgrounds of the students, you will also become aware of other ways to enrich your program.

A unit can be developed by identifying a major theme, selecting a topic and an appropriate text, and setting appropriate instructional objectives. Activities can then be selected to develop the skills you have identified as needed by the students.

1. Theme is a general organizational concept. Build your course around a theme or series of themes, rather than choosing different topics at random. In a course in English for Economics, for example, your general theme might be price policies, and your topics selected from that area of economics.

2. Topic is a convenient unit of syllabus organization. English is learned best in context, and the topics you choose will provide a context for learning. For computer science, in a unit whose theme is hardware and software, a list of topics might include the following:

#### **A. Hardware**

1. Mainframes, minicomputers, and microcomputers
2. Computer capabilities and limitations
3. Computer components: the processor, memory, input and output devices.

#### **B. Software**

1. Word processing
2. Data processing
3. Programming.

The topics of interest and importance to your students can be identified from your interviews with the subject-area instructors at your institution. Ideally, you can make your English instruction parallel to what the students are learning in their content courses for maximum transfer of knowledge and skills.

3. Texts which address your chosen topic should be selected with the students' needs in mind. Select one or more reading passages concerned with each topic you have chosen. Try to select readings and topics which build on each other and develop common vocabulary. The passages can be taken from commercial ESL or ESP textbooks relevant to the content area, or from authentic content-area materials such as research papers or textbooks. Guidelines for choosing texts of appropriate difficulty are provided in Chapter Five.

The reading passage serves as the unit core from which classroom activities and exercises are developed. Vocabulary, listening comprehension exercises, and grammar and writing exercises can be based on the reading selection chosen for each unit. The length of the passage will depend on your assessment of students' abilities, but it should be long enough to provide opportunities for practicing intensive reading and for increasing reading speed through extensive reading. Appropriate use of any text, of course, will depend on the skills that your students need to develop.

4. **Objectives:** Following your selection of topics and readings, appropriate objectives for instruction should be identified. Not only do you need to know the skills that you plan to teach in each unit, but your students will also benefit from knowledge of what your objectives are. Objectives should be written for each unit of instruction to address the specific skills that you want to develop in your students. Examples of broad objectives for the development of language skills are provided in Chapter Three; these can be used as references in writing specific objectives for each unit.

A spiral concept of program design is recommended. Such a design calls for "recycling" of materials to provide review and reinforcement of vocabulary and structures covered in earlier units. For example, the same text can be used to teach the four skills by using it one week for reading activities, another week for listening activities, and the using it again later in the program for writing or speaking activities.

### **Planning lessons**

After you have developed a unit outline, you will need to select and schedule activities for each lesson. It is helpful to build your lessons around a common format. For example, each Monday class might begin with a listening activity and then have a series of reading activities. On Wednesday you might work on grammar and writing. Having a common format to your lessons gives you a framework on which to build each unit and helps your students to become accustomed to your teaching routine.

Following is an example of how a topic and text can be used to develop a unit outline for a course in English for Computer Science. Following the unit outline is a two hour lesson plan.

The activities given here would be appropriate for a wide range of topics. Suggestions for other activities can be found in Chapter Three, Developing Language Skills. This sample unit has the following format:

- I. Text of the reading passage which forms the basis of the unit (Figure 14).
- II. Unit Outline: Content of unit, skills focus, and teacher's objectives.
- III. Lesson Plan: Detailed outline of activities for a two-hour meeting.
- IV. Student worksheets to accompany the lesson.

You should evaluate your program to determine whether you have met your goals and objectives, and then make adjustments to your program based on this evaluation. See Chapter Six, Program Management and Evaluation, for suggestions for testing.

## Sample unit: Computer science

### II. UNIT OUTLINE

(Content of unit, skills focus, and teacher's objectives)

Program: ESP for Computer Science

(This unit outline forms the basis for two class sessions. The lesson plan for one of the class sessions, which develops listening and reading, and study skills, follows this unit outline. The other class session would develop the grammar and writing skills outlined below.)

Topic: Software

Content:

**Reading Assignment:** Scientific Applications Software by John C. Nash, from Byte, December 1985. (See Figure 14). Vocabulary terms: program, style, computations, convenient, categories, package, equipped, programming language, operating system.

**Visual Aid:** Catalog/Chart: Software Tools for Scientific Computations.

**Mini-lecture topic:** Selecting Software: Reading a Catalog.

Skills focus:

**Listening:** Listening for specific information.

**Number practice:** Dollar amounts from \$100.00 to \$1000.00; decimals to one place.

**Reading skills:** Recognizing the author's organizational patterns.

**Study skills:** Using a catalog.

**Writing skills:** Writing a business letter.

**Grammar focus:**

**Reading:** Sentences that begin with subordinate clauses. See how the author uses them. Example: "When considering a particular program or package, you first have to determine what it is supposed to do."

**Writing:** Structures used to make requests: Example: "Please send me information about .." "I would like to know...", etc.

Objectives:

**Listening:** Students will be able to understand a lecture which describes the characteristics of software programs, as demonstrated by their ability to answer questions about the lecture.

Students will be able to understand dollar and decimal amounts used in context, as demonstrated by their ability to correctly write the numbers they hear.

**Reading:** Students will be able to recognize the organizational pattern of a text, as demonstrated by their completion of an outline of that text.

**Study Skills:** Students will be able to use catalog descriptions in English to identify software appropriate for their applications, as demonstrated by their selection of such software.

**Writing:** Students will learn the form of a basic business letter in English, as demonstrated by their ability to write a short letter asking for information about software programs.

**Grammar:** (Reading) Students will learn the structure of subordinate clauses, as demonstrated by their ability to find such structures in the reading text.

(Writing) Students will learn how to make polite requests in writing, as demonstrated by their ability to use such structures in writing a business letter.

## **LESSON PLAN**

(This is the teacher's lesson plan. Worksheets needed by the students for completion of the exercises outlined below follow this lesson plan.)

**Homework Assignment:** Read "Scientific Applications Software" and answer the questions about the article

(A reading selection appropriate to the unit topic serves as the core content of the unit. The students will find it helpful they are given the reading assignment as homework before the unit is introduced. This background reading will prepare them for the content of the lesson and give them added context for comprehension of the classroom exercises. See Student Worksheet 1: Reading Comprehension Questions.)

### **Class Activities:**

A. Mathematics language comprehension exercise. (5-10 minutes) Read the following and ask students to write the number they hear:

1. the software sources are listed on page 146.
2. The MATH/LIBRARY Program is available for \$440.
3. The program costs \$320 when purchased by universities.
4. NAG FORTRAN can be used with Microsoft FORTRAN 3.13.
5. You will need MS-DOS 2.0 to run most scientific programs.

(This activity is described more fully in Chapter Three, LISTENING COMPREHENSION)

B. Vocabulary building.(10 minutes)

See vocabulary exercise on Student Worksheet 2: Listening Comprehension Exercises. Read the sentences aloud and ask students to write the words they hear.

C. Listening Exercise: Mini-lecture (15-30 minutes)

Read the Mini-lecture (See Teacher's Script, below) asking students to answer the questions they hear on their worksheets. Then read the passage again so they can complete the close exercise. (See Student Worksheet 3: Cloze Exercise).

D. Reading/Study Skills (20-40 minutes)

**Outlining:** Complete the outline exercise together in class. (See Student Worksheet 4: Reading Activity)

### **Teacher's Script for Mini-Lecture:**



## **MINI-LECTURE: SCIENTIFIC SOFTWARE PRODUCTS**

Software provides useful tools for scientific computations. For those who do not know how to program computers, software makes the full power of the machine available. Even those who can program the computer often find it more convenient to use a commercial software package to save time and effort.

Look at the catalog, "software Tools for Scientific Computations." Here you see four categories of scientific software. Look at numbers one through four on your worksheet. Write the four categories of scientific software there.

Now look at the information given for each software package. Four pieces of information are given for each software package. The information given for each package includes the name of the package, the cost, a short description of the program, and an address where the software is available.

Look at the first program listed, "MATH/LIBRARY." What is the cost of this program for individuals? Now look at number five on your worksheet. Write the cost of MATH/LIBRARY at number five.

The description of MATH/LIBRARY tells which computers it is designed for. It is designed for an IBM PC or PC XT. The computer must be equipped with Microsoft FORTRAN, a programming language, and the operating system MS-DOS 2.0.

Now look at the description of NAG FORTRAN at the bottom of the first column of the catalog. For which computers is it designed? Write the name of the two computers at number six on your worksheet.

The catalog descriptions also list the kinds of mathematical problems that the programs can solve. These differ from package to package, and it is this information which tells you whether the software package will be useful to you. But the description does not tell the whole story. In order to really know if a program will help you in your application, you'll have to try it!

**Figure 14. Reprinted with permission from the December 1985 issue of BYTE magazine. Copyright © by McGraw-Hill Inc., New York 10020 All rights reserved.**

## **SCIENTIFIC APPLICATIONS SOFTWARE**

BY JOHN C. NASH

John C Nash (Nash Information Services 1975 Bel Air Dr. Ottawa Ontario Canada K2C OX1) is a computational mathematician whose research and writings cover many areas of computer applications. He is also a BYTE contributing editor

### ***How to find and select suitable scientific software***

To determine whether a scientific applications software package is suited to your needs, you should consider three things—the purpose of the package, the style in which it's presented, and its overall quality

Most of the software mentioned in the text boxes for this article is targeted for microcomputers and the applications are scientific and engineering tasks. But the suggestions I present should help you find and select scientific software in general

### **THE PURPOSE OF A SOFTWARE PACKAGE**

When considering a particular program or package you first have to determine what it is supposed to do. If it does not address your problems or needs it is unlikely to be of further interest to you.

Various sources of information can help you determine which software products have the functionality you need.

Because the subject matter of scientific software is complicated it is worthwhile subdividing topics not by scientific discipline but by the author's intended audience.

A program may have been developed to perform a particular computational task or tasks for a limited set of scientific or engineering problems. An example of this type of program is one that does structural analysis of buildings.

Or the software may have been developed as a general tool for use in data reduction, data analysis or documentation of works in a number of fields, such as a word-processing system for mathematical or scientific systems or a statistical package

Alternatively the package may have been designed primarily to educate users in a certain subject area rather than to provide serious computational power to practitioners. An example of this kind of program is one that illustrates how simultaneous linear equations are solved or one that prepares test questions in a specific discipline from a master set.

### **STYLE**

The way a software producer presents and packages his creation is the factor that most often causes buyers to rave or curse about software. If several software packages can perform the same function, style may become the hinge of your buying decision.

To determine if a program's style suits you, you should consider three things - the way in which the program must be used, the level of satisfaction or frustration you experience while using it, and the suitability (or fit to application) of the program's packaging and documentation.

Although it is relatively easy to list the features of a software product, even extensive reviews may fail to capture the style of the product. The expanding availability of demonstration disks (especially those that allow you to try all of a program's function) is to be welcomed as an aid to software selection.

The three subdivisions of software I described earlier - software designed to perform certain tasks, to be used as a tool, or to be used as a teaching aid - can also be applied to the discussion of style.

***For your own protection, you should be aware of the quality of a scientific program before you buy it.***

## SOFTWARE TOOLS FOR SCIENTIFIC COMPUTATIONS

There are a number of software products that attempt to cover most aspects of scientific computation. Others provide a toolbar for a given area of application lack Dongarra looked at some of these and provide much of the information below.

### GENERAL SCIENTIFIC SOFTWARE COLLECTION

- MATH/LIBRARY

\$440, \$320 for universities

This selection which is from the well-known IMSL subroutine library is for use on an IBM PC or IBM PC XT with Microsoft FORTRAN 3.2 UNDER MS-DOS 2.0 it contains 540 mathematical subroutine to solve for differential equations and integration eigensystem analysis error functions gamma functions, interpolation approximation smoothing linear algebraic equations, nonlinear equation, optimization and vector matrix arithmetic and sorting. Both single and double precision versions of the routines are available. Contact IMSL Inc. 7500 Bellaire Blvd. NBC Building, Houston TX 77036-5085.

- microSUB MATH..... \$250

This program consists of a set of FORTRAN subroutines in relocatable-object form. The subroutines cover special math function, interpolation, integration, matrix/linear systems, polynomials/nonlinear systems and differential equations. Contact Foehn Consulting POB 5123 Klamath Falls OR 97601.

- NAG FORTRAN ... Library

\$345, 20 percent off for universities

This package consists of 50 routines from the NAG FORTRAN library. It can be run on the IBM PC with Microsoft FORTRAN 3.13 under MS-DOS 1.0 (or later) and on the IBM PC XT with Microsoft FORTRAN 3.2 under MS-DOS 2.0 The routines cover a wide range of subjects in numerical and statistical computing including root finding, Fourier transforms, quadrature ordinary, differential equation, optimization, linear algebra, basic statistic, random numbers, linear programming and special functions. Contact Numerical Algorithms Group Inc. 1011, 31<sup>st</sup> St. Suite 100. Downers Grove Il, 60515

- The Scientific Desk

One-time fee \$540, maintenance fee \$84 per year

This library of subroutines can be called by a user an embedded in his or her program. The package has a set of applications program menus called Problem Solving Environments (PSEs). The PSEs provide the user with a set of commands that are familiar to the subarea and can be used without programming. They provide programs in the following areas simultaneous linear equation solving, vector/matrix arithmetic, inversion matrix condition estimation and statistical inference and estimation. They can handle real matrices stored in two-dimensional form, calculate the roots of polynomials eigenvalues and eigenvectors for real square matrices. Contact C. Abaci Inc. 208 St Mary's St Raleigh NC 27605

### SOFTWARE FOR LINEAR ALGEBRA

- LEOB05..... \$50

This small linear-algebra algorithm package (of BASIC source code) consists of a number of subroutines and three driver programs that on most computer systems can be loaded simultaneously. The program solve the following types of equations linear least-squares problems, linear equations problems, matrix inverse, matrix eigenvalue, problems for symmetric matrix and non-linear least-squares problems. Contact C. Abaci Inc. 208 St Mary's St Raleigh NC 27605

- LINPACK.....\$75

This collection of FORTRAN subroutines analyzes and solves linear equations and linear least-squares problems. The package solves linear systems whose matrices are general banded



## SEARCH AIDS

### ON-YEAR DATABASES

It is often difficult to find the "right" software by means of a database search because of the general lack of precision of the search process. Either the number of "hits" will be large and most citations will prove to be of marginal value or the number of hits will be small because the search can find few records in the database that match the search profile entered. One reason you may end with a large number of hits is that vendors want you to see their entries even if they aren't of direct value to you. Therefore the product description they put in the database is often overly generalized. Another reason this happens is because database suppliers want to have as many entries as possible so they pay little attention to the package's quality or even its existence, (apart from an announcement).

Despite these drawbacks, I recommend the following three databases that may be of help to you in your search for scientific software. These are available through the knowledge index service of Dialog Information Services, 3460 Hillview Avenue Palo Alto, CA 94304. There are also agents in other countries around the world. The service rates for these databases (at the time of this writing) are \$35 initial fee for manuals and two hours of on-line use hereafter (Note that there are other database services that may provide these files)

- Menu-International Software Database (produced by Imprint Software Ltd.)
- Microcomputer Index – (produced by Microcomputer Information Services 1982)
- Mathfile – (produced by the American Mathematical Society) The first two of these files focus on mini-and microcomputer software offerings while Mathfile contains abstracts to the mathematical, statistical and computing literature including application areas and covers approximately 1600 journals.

### PUBLICATIONS

The following is a list of periodicals, catalogues, and reports that often discuss scientific software packages. Some of these sources are devoted to particular subject areas. This is not a complete list, there are other sources that offer reviews of interesting software. To obtain more information on these publications, contact the addresses provided.

- **ACM Transactions on Mathematical Software.** Although this periodical is mainly devoted to mainframes some of the material may be suitable to microcomputers. Contact the Association for Computing Machinery, 1133 Avenue of Americas, New York, NY 10036
- **Advances in Engineering Software** Some articles include program code Microcomputers are increasingly being featured in this magazine. Contact CML Publications, 125 St. Southampton SO1 0AA, England
- **American Statistician** This magazine includes announcements of statistical software. It also has a regular statistical software review section. The emphasis is on microcomputer software. Contact the American Statistical Association 806, 15<sup>th</sup> St NW, Washington DC 2005.
- **AMSTAT News** This magazine is mainly of value for its advertisements which are directed at professional statisticians it often lists workshops and meetings where software is to be discussed. Contact the American Statistical Association 806, 15<sup>th</sup> St NW, Washington DC 2005.
- **BYTE The Small Systems Journal** This magazine provides monthly software reviews. Contact BYTE, 70 Main St. Peterborough, NH 03458
- **The College Mathematics Journal** This journal has a regular software review column. Contact the Mathematical Association of America, 1529 18<sup>th</sup> St. NW, Washington DC, 20036.
- **Computer Physics Communications.** Includes a section on software but mainly is of use to mainframe users. Contact North-Holland Publishing Company, Box 211, 1000 AE, Amsterdam, Netherlands.

## STUDENT WORKSHEETS

(Note: Answers are given in parentheses for the convenience of the teacher. These answers would not, of course, be included in the student copies of the worksheets.)

### Student Worksheet 1: Reading Comprehension Questions

**Reading:** Scientific Applications Software by John C. Nash, from Byte, December 1985.

**Assignment:** Read the article and answer these questions before coming to class.

#### Comprehension Questions:

1. According to the author, what are three major considerations in choosing scientific applications software? (The purpose of the package, the style in which it's presented, and its overall quality.)
2. What are some purposes for which scientific software has been developed? (To perform particular computational tasks, as a general tool for data analysis, or to educate users.)
3. What are the three aspects of program style that the author considers important? (The way in which the program must be used, the level of satisfaction or frustration you experience while using it, and the suitability of the program's packaging and documentation.)
4. Why is it difficult to find commercial software that is easily modified by the user? (Because there are difficulties in protecting the authorship of such programs.)
5. What considerations does the author mention regarding software quality? (Interactions between the scientific software and word processors or database managers, reasonable results on approximations and iterative processes such as floating point decimal operations, and diagnostic information that allows troublesome situations to be understood and corrected.)
6. How can the buyer assess the quality of software?

(By reading reviews by professionals in the field and checking authorship, methods of program development, the history of the software, and the reputation of software producer and vendor.)

### Student Worksheet 2: Listening Comprehension Exercises.

**Topic:** Scientific Applications Software

Vocabulary Practice

Choose the word from the list below which best completes each sentence:

operating system  
convenient  
computations  
equipped  
programming language  
package  
categories  
program  
style

1. Software provides useful tools for scientific \_\_\_\_\_.

2. This catalog lists four \_\_\_\_\_ of scientific software.
3. If several programs can perform the same function, \_\_\_\_\_ may become the most important feature.
4. Software usually requires that your computer be \_\_\_\_\_ with particular features.
5. Most programs are written for a particular and \_\_\_\_\_.

**MINI-LECTURE: SCIENTIFIC SOFTWARE PRODUCTS**

Directions: Listen to the mini-lecture and answer the questions on the spaces below.

1. \_\_\_\_\_
2. \_\_\_\_\_
3. \_\_\_\_\_
4. \_\_\_\_\_
5. \_\_\_\_\_
6. \_\_\_\_\_

**Student Worksheet 3: Cloze Exercise.**

**MINI-LECTURE: SCIENTIFIC SOFTWARE PRODUCTS**

Directions: Some words are missing from this passage. The missing words are contained in the word list. First read the passage silently. Then listen as you hear it read twice. After the first reading, you will have two minutes to fill in the missing words. Then you will hear it again and can check your answers.

Word List

software	where	IBM
individuals	the	kinds
those	lists	linear
for	must	can
tells	program	you'll
of	description	package
find	be	order
commercial	include	does
computations	how	full

Software provides useful tools for scientific \_\_\_\_\_. For those who do not know \_\_\_\_\_ to program computers, software makes the \_\_\_\_\_ power of the machine available. Even \_\_\_\_\_ who can program the computer often \_\_\_\_\_ it more convenient to use a \_\_\_\_\_ software product to save time and effort.

The catalog, "Software Tools for Scientific Computations," \_\_\_\_\_ four categories of scientific software. These \_\_\_\_\_ General Scientific Software Collections, Software for Algebra, Software for Nonlinear Equations, and \_\_\_\_\_ for Mathematical Programming.

The information given in the catalog \_\_\_\_\_ each software package includes the name \_\_\_\_\_ the package, the cost, a short \_\_\_\_\_ of the program, and an address the software is available.

The first program listed, MATH/LIBRARY, costs \_\_\_\_\_\$440. It is designed for an \_\_\_\_\_PC or PC XT. The computer \_\_\_\_\_be equipped with Microsoft FORTRAN and \_\_\_\_\_operating system MS-DOS 2.0.

The catalog descriptions also list the \_\_\_\_\_of mathematical problems that the programs\_\_\_\_\_ solve. These differ from package to\_\_\_\_\_ and it is this information which \_\_\_\_\_you whether the software package will be useful to you. But the description \_\_\_\_\_not tell the whole story. In \_\_\_\_\_to really know if a \_\_\_\_\_will help you in your application, have to try it!

#### **Student Worksheet 4: Reading Activity**

#### **READING ACTIVITY: Completing an Outline**

**Directions:** Use the reading text to complete the following outline. [NOTE: Suggested answers are given in parentheses.]

#### **SCIENTIFIC APPLICATIONS SOFTWARE**

##### **A. Purpose of a Software Package**

1. \_\_\_\_\_(for a particular computational task)
2. \_\_\_\_\_(as a general tool for data analysis)
3. \_\_\_\_\_(to educate users)

##### **B. Style Considerations for Purchasing Software**

1. \_\_\_\_\_(the way the program is used)
  - a. \_\_\_\_\_(single programs or subroutines)
  - b. \_\_\_\_\_(menu-driven)
  - c. \_\_\_\_\_(user modifiable)
2. \_\_\_\_\_( level of satisfaction you experience using it)
3. \_\_\_\_\_(packaging or documentation)

##### **C. Quality Considerations**

1. \_\_\_\_\_(operates correctly on tasks shared with other programs)
2. \_\_\_\_\_(approximations and iterative functions are reasonable)
3. \_\_\_\_\_(diagnostic information is output)

##### **D. How to Judge Software Quality**

1. \_\_\_\_\_(reviews by competent professionals)
2. \_\_\_\_\_(documentation of authorship)
3. \_\_\_\_\_(methods of program development)
4. \_\_\_\_\_(history of the software)
5. \_\_\_\_\_(reputation of producer and vendor)

### **Chapter five: Materials selection and development**

The materials you teach should be chosen primarily for their relevance to the content area. You may select them from authentic materials used in content-area instruction or from commercial



materials. Developing materials is time- and energy-consuming, so you should take advantage of any materials which are already available for your use. The Resources Section (Appendix A of this Manual) describes materials that are available through Peace Corps' ICE. All of the materials listed have been evaluated for use in Peace Corps ESP programs and are highly recommended. You are encouraged to order copies.

### **Assessing reading difficulty**

When choosing texts for use in the language classroom, your goal is to select passages that challenge the students without being too difficult. If you want to determine in advance whether a particular text will be too difficult for your students, you can use the following procedure to find out whether your students will be able to understand it. This exercise should not be overdone -use it to check a few passages you plan to use and then use those as general guidelines for selection of other texts.

Following is a procedure for construction of a cloze passage to check reading level and difficulty. Such a passage is easily made and easily scored. Follow these steps:

1. Choose a passage of approximately 250 words from the text you are considering for use in the classroom.
2. Reproduce the 200 words on a mimeo worksheet, deleting every 5th word and replacing it with a blank. (Use 50 blanks for an easy percentage calculation when you correct them.) Note that names and numbers should be skipped when they come up as potential blanks, and the next word chosen.
3. Number the blanks for easy scoring. If you provide an answer sheet, students will not need to write on the exercise itself and you will be able to refuse it.
4. Stress to the students that this is not a test. Tell them you are determining whether the material is at the right level of difficulty for them to read. Ask them to read the passage and write an appropriate word in each blank. Do not time the test; give students ample time to complete it.

Evaluating the results:

1. For ease and speed in correcting the papers, accept as correct answers only those words from the original text which were deleted. Students may provide synonyms which are appropriate, but accepting these will not help you decide if the reading selection is appropriate for the whole class. (Looking at such answers may help you when working with students individually or as they work together in diagnostic or learning situations.)
2. Compute the average score of the whole class's performance. Second language students will not be able to fill in more than 60-70% of even easy material. Evaluate the results according to these guidelines:

If the class's average score is greater than 53% (independent reading level), they can probably read the story on their own or at home. If the average score is less than 43% (frustration level) it is too difficult even for classwork. The ideal is to get a set of scores for all students which is greater than 43% and less than 53%. This material can then be used for instructional purposes.

(From John F. Haskell, in Classroom Practices in Adult ESL, TESOL, Washington, D.C. Copyright 1978 by Teachers of English to Speakers of Other Languages. Reprinted by permission of the publisher and John Haskell.)

These figures are not absolute, but they can provide you with an initial indication of the suitability of materials for classwork and independent reading. Experiment with your own group to find the right level of material.

### **Selecting materials**

Look at potential materials in terms of their comprehensibility to the students. In order to judge complexity, look at the following features:

1. Length: shorter texts will be easier to read, in general, than longer texts.
2. Internal complexity: texts made up of simple sentences will generally be easier to read than texts which contain many complex constructions.
3. Density of new information: texts whose content is already somewhat familiar to students will be easier to read than those with unfamiliar content.
4. Presence of supportive graphics: Pictures, charts, and other graphics provide context and make reading easier.
5. Organizational pattern: texts which follow a chronological or logical progression in the sequence of events or actions are more likely to be understood.
6. Degree of abstraction: texts that provide a concrete discussion of events rather than analysis or speculation will be clearer.

If passages are complex and dense, they should be short so that they can be read intensively. But students also need practice in developing their reading speed, and to do this they need to read longer selections as well. Passages which follow a chronological order or provide clear descriptions can be long and still be accessible to the students. Supportive graphics are particularly important. Select texts which present a concept clearly through visual or graphic examples. Visual aids contribute much to the comprehensibility of a reading passage.

Other aspects of texts which affect their readability are the relevance of the topic to the students' interests, the task students are asked to do with the material, and the cultural context of the reading. Material which is not apparently relevant will be more difficult for students to comprehend. Tasks appropriate to different levels of reading complexity are suggested in Chapter Three, Developing Language Skills. Texts should also be assessed to ensure that they are not so culture-bound as to be incomprehensible to learners from other cultures. The cultural context is crucial because materials whose cultural content the students find objectionable will not only be incomprehensible, but may in some cases also alienate them.

Students do not have to understand every part of every reading passage they work from. You can use materials from which students can gain some skill or insight, even if total comprehensibility is not achieved. Students will accept this if they are told that they are reading a particular text for specific information or for a particular purpose; for example, if students are asked to scan an article to find the answer to questions you give them. The text can then later be "recycled" at a higher level as the students gain in proficiency.

### **Developing your own materials**

Developing appropriate materials takes lots of time and effort, but the end product is usually something that meets the specific needs of your students better than commercial materials. You will probably have a good collection of materials you have prepared yourself by the end of your course. You can ensure that other Volunteers who follow you in your position will be able to make

good use of your work if you label each exercise and organize your materials in a way which will be clear to someone new coming into your job.

Peace Corps' ICE is also constantly looking for Volunteer developed materials which have broader value. Send copies of the materials you develop to ICE so that they can review them for possible publication. In this way materials with wider applicability can be made available to other Volunteers teaching- ESP in the same content area.

This Manual stresses the use of authentic subject area reading texts as the core for your instructional units. If you are unable to find texts at a reading level appropriate for your students, you may consider simplifying or adapting more difficult materials. Such a process should be undertaken with caution, however. Studies have shown that when material is simplified, it often becomes more difficult to understand. Features which contribute to comprehensibility are unintentionally eliminated by the native speaker who attempts to simplify a text. The relationships between sentences may become unclear, or natural redundancy may be eliminated. The coherence of the passage may suffer.

If you cannot find texts at the right-level of difficulty for your students, however, the following guidelines can help you to adapt texts for students with low-level skills.

First, start with an original text which expresses an idea or presents some information that you want your students to know. Reduce this text to a list of separate points. Then recombine these points, using maximum redundancy and clarity. For example: Figure 15 is an article from TIME magazine with content interesting to a science class. Some main points were selected from the article:

1. A massive object has been discovered in space.
2. The object was discovered when physicists realized that what appeared to be two quasars was actually the same quasar.
3. The light from the quasars is diverted by the intense gravitational field of the object in space.

These points, along with details from the article, were used to develop the simplified text in Figure 15. The diagram was also simplified to eliminate extraneous information and to highlight the most relevant features. The important point here is that instead of starting with a complex text and simplifying it, you should start with the ideas that are important and compose a text yourself. In this way the features of natural language will best be preserved.

Often authentic materials can be used in ESP classrooms without simplification, especially if the students' reading ability is at a higher level than their other skills, as is often the case. Some commercial publishers use authentic reading passages in their texts, glossing words that students may not know. An example of such a passage is given in Figure 16.

If you select reading passages from subject area texts or articles, you will have to develop your own reading comprehension activities to accompany them. The type of questions you ask depends, first, on whether the students are reading intensively or extensively (see Chapter Three, READING.) Questions for intensive reading first ask about concrete information and general ideas. In both types of reading, questions should be asked about the author's point of view or the student's own opinion of what was said. In extensive reading, check only comprehension of important points in the story, not minor details.

Following are some types of comprehension questions, followed by examples based on Figure 16:

- 1) Questions which refer to persons, identification of place, etc. Example: What are some American products that are recognized for their high quality? (Answer: commercial aircraft, tractors, sheets, plastics, chemicals, machine tools.)
- 2) Finding sentences or words that are redundant (that express the same meaning). Example: Find three words in paragraph five that have the same meaning as the word "company. " (Answer: pacesetters, industries, makers.)
- 3) Making a list of words which belong to the same category. Example: Find several words in the article which are used to describe high quality. (Answer: long-wearing, stronger, purer, flawless, etc.)
- 4) Questions which ask what is being referred to in the text when a reference is made to some other part of the text. Example: What does "the word" in the first sentence of paragraph six refer to? (Answer: quality.)
- 5) Find and underline the sentence or sentences which express the main idea of the passage. (Answer: The first sentence of paragraphs two and three.)
- 6) Outlining. Initially, you can prepare a skeleton outline for the students to fill in. (See example in Chapter Four, Program Design). Eventually, they can prepare their own. The outline should be designed to reveal discourse organization features; that is, how the author has organized the material. Focus on transitions and other words used to structure the material. The outline should reveal the intent of the writer, and what and where new information is introduced.
- 7) With texts that are chronologically organized or which describe a process, students can be given a scrambled version to re-order.
- 8) Students can be asked to make a sketch of something which is described in the text.
- 9) Students can be asked to summarize the text, including showing how the author perceives and addresses the audience.
- 10) Students can be asked to give an opinion of the text.

**Figure 15. Reprinted with permission from the May 19, 1986 issues of TIME magazine. Copyright © by Time-Life, Inc. All rights reserved.**

## Science

### Through a Lens Darkly

#### ***Twin images signal the discovery of a mysterious cosmic object***

It was a coal-black night in March, the kind astronomer like best. At Arizona's Kitt Peak National Observatory. Princeton Astrophysicist Edwin Turner pointed the 158-in, reflecting telescope first at one distant pinpoint of light in the sky, then at a neighboring one. A few hours later, studying the results of his night's labors, Turner could hardly believe his eyes. "It was a big surpass." he says. "But a big surprise is always a clue you might be on the track of something."

Something indeed. After analyzing the light born the distant sources, Turner and seven other scientists concluded that they had apparently found evidence of the most massive object ever detected. That object, they surmise in a report published last week in *Nature* could be a huge cluster of galaxies or a black hole far larger than any ever anticipated. More startling, it might be a "cosmic string," a bizarre, hypothetical remnant of the chaotic birth of the universe

The Kitt Peak telescope had been aimed at what appeared to be two quasars, mysterious, intensely bright bodies so far away that the light they emit travels for billions of years before reaching the earth. Gathered by the telescope's parabolic mirror, the light from each of the quasars was converted into a spectrum from which a quasar's characteristics and even its distance can be determined. Most scientists believe that each of the some 3,000 known quasars, and thus the spectrum of each, is unique. Says Charles Lawrence, a Caltech astronomer and a co-author of the *Nature* paper "Quasar spectra are something like fingerprints, and no two are the same"

But as Turner confirmed, the two spectra recorded at Kitt Peak were virtually identical. This meant that if each were from a different quasar, the two objects would not only have identical chemical properties and temperatures but also would be the same distance (about 5 billion light-years, in this chase) away - a highly unlikely coincidence. "If you get matching fingerprints," Turner says, "you could have images from the same quasar."

How does one quasar produce two images? The answer, astronomers say, lies in a "gravitational lens," an immense object with a powerful gravitational field located somewhere between the quasar and the earth. As light from the quasar approaches the object it is diverted from original path by the intense field (see diagram) and produces what earthbound observers see as multiple images.

As long ago as 1915, Albert Einstein predicted that as a consequence of his general theory of relativity, light rays would be bent if they passed through the intense gravitational field of a massive object. That prediction was confirmed by British Astronomer Arthur Eddington in 1919, when he traveled to an island off West Africa to observe a total solar eclipse. From there he was able to measure precisely the location of a star that became visible in the suddenly darkened sky near the edge of the sun. Because light from the star was bent by solar gravity as it passed the sun, the apparent position of the star in the sky was slightly displaced from its known position by the amount that Einstein had predicted.

By the 1930s, Einstein and other scientists had recognized the possibility of a gravitational lens effect but doubted that it would ever be observed. Then, in 1979, two Britons and an American working at Kitt Peak observed the first lensing phenomenon - two quasar images with virtually identical spectral characteristics. Their conclusion something, later shown to be a cluster of galaxies, was serving as the gravitational lens, obscuring the actual quasar but bending its light rays to form an image on either side. Since then, five other examples of quasar multiple images have been observed. and intervening lens galaxies found for three of them.

While none of these previous multiple images was separated in the sky by more than seven arc seconds,\* the latest dual quasar images are 157 arc seconds. or more than 22 times as far apart. In order to bend light that much, the lens must have the mass of a thousand galaxies. Says Turner: "It

was like looking for a Cal in the backyard and comma up with an elephant."

So far, however, it is an invisible elephant. Says Co-Author Maarten Schmidt, the Caltech astronomer who 23 years ago discovered that quasars were the most distant and intrinsically brightest objects in the sky: "The fact that we do not see anything there makes it rather challenging. It is difficult to hide an appropriate cluster of mass between us and the quasar."

Rising to the challenge Turner's team suggests another possible source of the powerful gravitational lens: a black hole least a thousand times as large as the Milky Way galaxy (which consists of hundreds of billions of stars, including the sun) if that black hole exists, it should be producing dual images of other quasars nearby in the sky and astronomers have begun to seek them out. Still, astrophysicists find it difficult to explain how so tremendous a black hole could have formed.

The *Nature* report mentions another intriguing possibility for the lens effect: the cosmic string. This weird one-dimensional creature was derived mathematically by physicists pondering the events that occurred in the first fraction of a second after the Big Bang created the universe. In theory these strings were either infinitely long or enclosed in a loop and could move at nearly the speed of light. Although infinitesimally thinner than the nucleus of an atom, those that have survived should have formidable gravitational fields. Each mile of length could contain a mass equivalent to that of the earth. As in the case of black holes, strings would theoretically produce double images of other nearby quasars. Explains Schmidt "Since there are other quasars in the region, one I would expect to see some of them doubled as well."

Turner also has reservations "I give the cosmic string theory less than a fifty-fifty chance of being the answer," he says. "But if it is, it would be extremely exciting. Just think, we would be looking at a fossil of the Big Bang." **By Jamie Murphy. Reported by John D. Hull/Los Angeles and William Sonzski/New York**

\* Each degree of arc in the sky is divided into 60 arc minutes and 3,600 arc seconds. The full moon spans a half degree, or 30 arc minutes.

Diagram

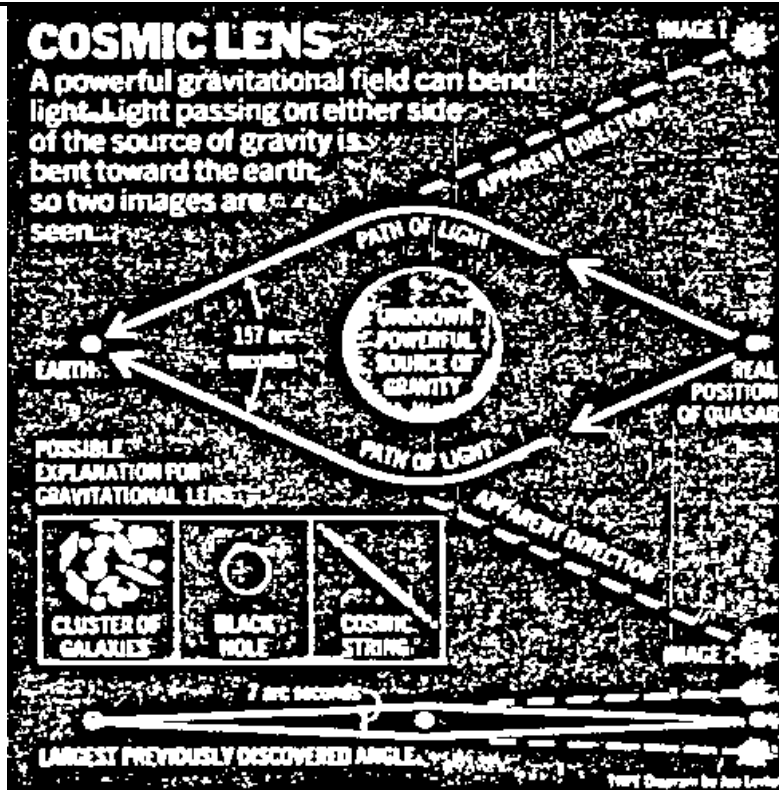

Simplified Version:

Astrophysicists at an observatory in Arizona have discovered a mysterious cosmic object. Their telescopes had been aimed at what appeared to be two quasars: mysterious, intensely bright bodies so far away that their light travels for billions of years before reaching the earth. Most scientists believe that each of the 3,000 known quasars is unique. Says astronomer Charles Lawrence, "Quasars are like fingerprints, and no two are the same."

However, when the astrophysicists in Arizona put together information on the characteristics of the two quasars, including their distance from the earth, they discovered to their amazement that the two quasars were identical.

This is such an unlikely possibility that the astrophysicists realized they must be receiving two-images from one quasar. But how does one quasar produce two images? The answer, say astronomers, lies in a "gravitational lens," an immense object with a powerful gravitational field, located somewhere between the quasar and the earth. As light from the quasar approaches the object, it is diverted from its original path by the immense gravitational field (see diagram), and produces what people on earth see as two images.

Diagram

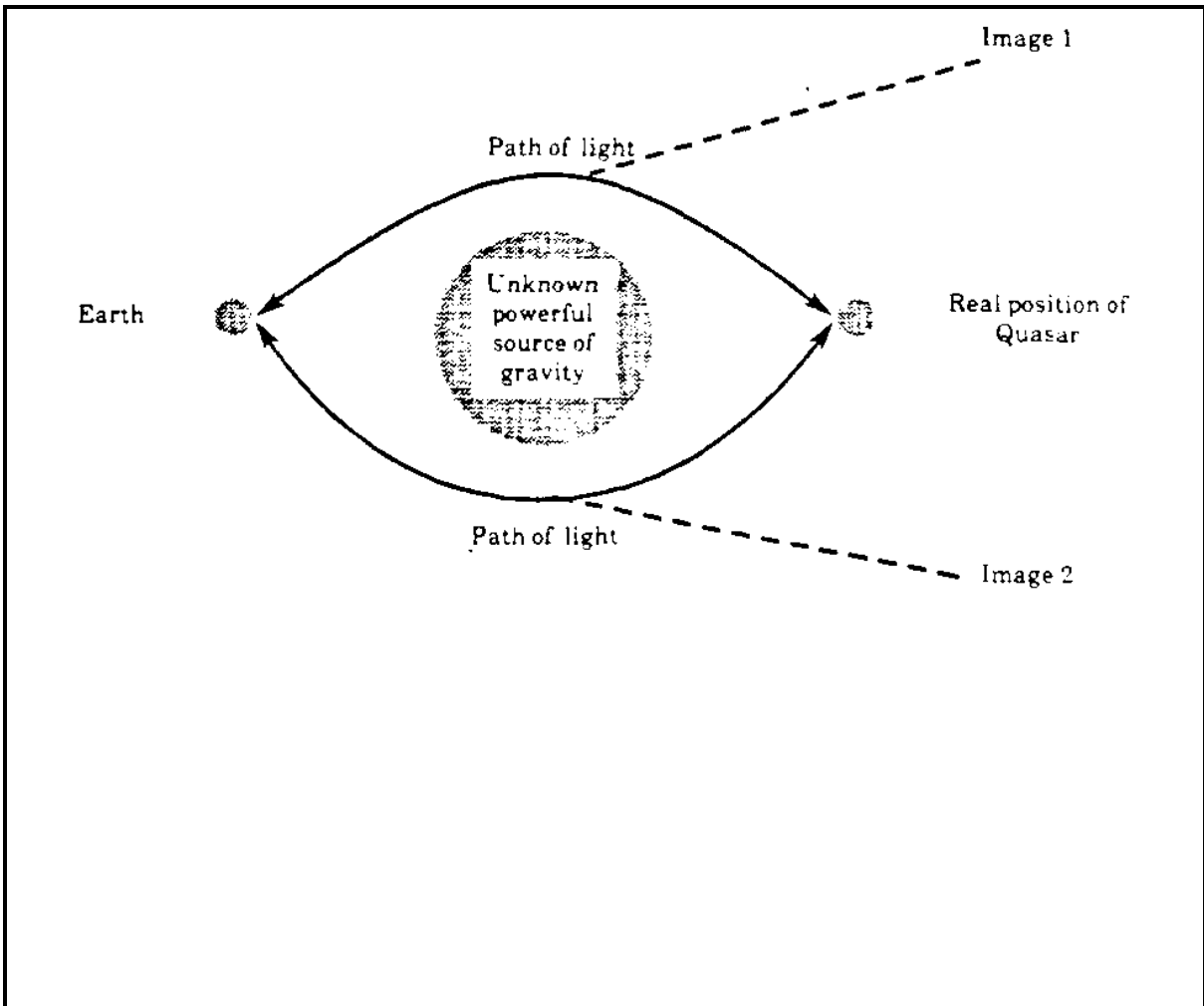

**Figure 16** "The Battle for Quality Begins" by J. Main. FORTUNE magazine, December 29, 1980. © Time Inc. All rights reserved. From Business World by R. Speegle and W. B. Giesecke, Copyright 1983 by Oxford University Press. Reprinted by permission.

### **CHAPTER EIGHT: The Battle for Quality Begins**

Jeremy Main

*Fortune*



<p>“<b>Quality</b>” has a special meaning in industry. It not only indicates the excellence or superiority of a product, but often implies also the measures that must be taken in order to control or assure quality.</p> <p><b>Reliable:</b> dependable, which will remain in working order over the normal life of the product</p> <p><b>Adjustable:</b> which can be moved or changed according to need</p> <p><b>Beside the point:</b> having little to do with the subject, irrelevant.</p>	<p>Why are we suddenly so worried about the <b>quality</b> of American products? Boeing makes the best commercial aircraft in the world. International Harvester and Deere &amp; Co. produce the most <b>reliable*</b> tractors-equipped, if farmers want, with stereos, air conditioning, orthopedic seats, and adjustable steering wheels. European tourists carry off American-made permanent-press sheets because they're cheap, long-wearing, and dazzlingly patterned. Our plastics are stronger, our chemicals purer, and our machine tools built to finer tolerances than ever. This is all true enough - yet, unhappily, it is also largely <b>beside the point.</b></p>
<p><b>Impermeability:</b> invisibly, so slowly as to be invisible</p> <p><b>Clout:</b> power, influence</p> <p><b>Vendors</b> (also venders) those who sell (especially to manufacturers)</p> <p><b>Periodically:</b> now and then, sometimes, from time to time</p>	<p>America's leadership in quality has been almost <b>imperceptibly*</b> eroding for years. More and more U.S. executives have awakened to the fact that they are caught in a fateful struggle. They are turning their companies upside down to give quality specialists more <b>clout.</b> <b>Vendors*</b> are being told to supply better parts or lose the business. In hundreds of factories, small groups of workers are sitting down <b>periodically*</b> to search for ways of improving quality and productivity.</p>
<p><b>Assiduously:</b> with extreme care, diligence, or persistence</p> <p><b>Chips:</b> extremely small squares of semiconducting material used in micro-electronics</p>	<p>While U.S. companies have steadily improved quality, times are coming under pressure largely because the Japanese have advanced by leaps. Building <b>assiduously*</b> for 30 years on a foundation of theories developed in the U.S., the Japanese have made quality the weapon that wins the world's markets. A few bald facts show how well they have done: A new American car is almost twice as likely to have a problem as a Japanese model. An American color TV needs repair half again as often as a Japanese set. U.S.-made computer-memory chips were judged in one test year to be three times as likely to fail as Japanese chips. There's no question that the Japanese have set new world standards," says Robert E.</p>
<p>Cole, who has worked in Japanese factories and now directs the University of Michigan's Center for Japanese Studies. "Their best factories are better than our best factories "</p>	

<p>Robert B Reich, director of policy planning in the Federal Trade Commission, summarized the <b>consequences</b> of the relative decline in American quality in a speech this year [1980]: "In industry after industry, consumers in America and elsewhere are fuming their backs on U.S.-manufactured products in favor of foreign competitors. 28% of our automobiles are now manufactured abroad by non-U.S. companies, 30% of our sport and athletic goods, 34% of microwave ovens, 90% of CB radios and motorcycles, almost 100% of video cassette recorders. The list goes on and gets longer year by year: radial tires, calculators, televisions, food processors, premium beer, cameras, stereo components, digital watches, pianos, bicycles, outboard motors"</p>	<p><b>Consequences:</b> results, effects</p>
<p>Among U.S. companies, it's often hard to identify the special characteristics that divide those that lead in quality from those that have fallen behind. Certainly the <b>pacesetters</b> are run by people who insist on excellence, often by an individual or family with a reputation to protect. Beyond that, though, none of the usual influences on industrial performance - <b>unionization*</b>, <b>capital intensify*</b>, <b>the number of competitors-seems to explain quality disparities*</b> among companies or industries. Nor is there reason to suspect that today's makers of even the best U.S. products - farm equipment, aircraft, machine tools, large appliances - will be <b>immune</b> to future threats</p>	<p><b>Pacesetters:</b> those who create the standards, especially the highest standards.  <b>Unionization:</b> formation of associations (unions) for the purpose of supporting workers interests  Capital intensity: the extent to which capital must be invested per product  <b>Disparities:</b> differences, gaps  <b>Immune: not subject or susceptible to (something), free from</b></p>
<p>One thing that complicates thinking about quality is that the word can mean just about whatever a customer thinks it means. To the fashion-conscious, quality might mean the patch that transforms a \$20 pair of jeans into a \$40 pair. To a space scientist, quality represents a million parts so carefully made, tested, and assembled that they will function flawlessly for years. <b>A working</b> definition of the quality most sought today might be "fitness for use, plus reliability, delivered at a marketable* price"</p>	<p><b>Working:</b> practical, effective</p>

<p>The principles for improving quality were developed in the U S before and during World War II - and then <b>neglected</b> here But Americans have been teaching the principles to the Japanese for three decades. with extraordinary results When industrialists mowed into the postwar power <b>vacuum</b> in Japan. they say. that the economy depended on <b>wiping out</b> the nation's image as the world's <b>purveyor</b> of junk In 1950. the Japanese invited W. Edwards Deming, a Census Bureau statistician, to lecture on methods he had developed for statistical analysis of quality Four years later. they asked Joseph M. Juran, a Western Electric quality manager, to instruct them on management's role in improving quality.</p>	<p><b>Neglected:</b> given no or not enough care or attention  <b>Vacuum:</b> a space occupied by nothing  <b>Wiping out:</b> destroying, ruining  <b>Purveyor:</b> seller</p>
---	--

### Using commercial materials

Because you will probably be unable to order class sets of books for your students, the commercial materials you do have available will be useful to you more as resources than as textbooks. You will be able to select those activities and exercises which are relevant to your students' needs. See Appendix A for titles and descriptions of materials available through Peace Corps' ICE.

### Chapter six: Program management and evaluation

Depending on your teaching experience, you may at first feel overwhelmed by the large classes and diverse needs that you face as an ESP teacher. The purpose of this chapter is to provide some tips to help you manage the language learning environment in the classroom.

Initially, students may experience problems in listening comprehension, remaining attentive, and following instructions. Your first class meetings, then, should be seen as opportunities to establish a routine, communicate your objectives, and allow the students to become accustomed to your teaching style.

You may have to adapt your style of speaking at the beginning of your program so that students can understand you. Some controversy does exist in language teaching about whether or not teachers should adapt their speaking style. It is argued that this exposes the students to inauthentic language and will not prepare them for understanding English spoken at a normal rate of speed. Of course, your ultimate goal is to enable your students to understand natural speech, spoken at normal speed, but at first you may need to speak more distinctly, allow more frequent pauses than normal, and say things more than once and in more than one way in order to be understood. As students get to know you better their understanding will improve.

The students will feel most comfortable and secure in their learning situation if you design a program which is well structured and in which your expectations for the students are clear. Take extra time in the initial class meetings to explain how each exercise should be approached. This time will be well spent, as later class meetings will then fall into a routine, assignments will be completed as expected, and students will recognize their steady progress.

Make your initial introduction of concepts and vocabulary highly contextualized through demonstration. Do not deny students the extra help that contextual clues give, or comprehension will be more difficult and the students will not develop strategies for exploiting context clues. The visual is the most important clue. A typical lesson should demonstrate. Use language, gestures,

and eye contact to establish meaning, and take advantage of the students' knowledge of the world. Tasks appropriate to this kind of treatment include description of a process, conducting of experiments, and explanations of charts or graphs. When you ask questions, discourage rapid reaction replies. Have a slow paced classroom in which everyone has time to think. If you are lecturing, stop every few minutes to allow students to get down notes, discuss briefly among themselves and ask questions. You may find it valuable to circulate through the class from time to time to discuss and answer questions.

Use short handouts and visuals. Give a handout after your first treatment' of a theme to give students the opportunity for listening comprehension practice before they read the handout to confirm, correct, or expand their notes.

When students ask questions in class:

- 1) Do not say too much. Omit all information that is not demanded by the question. Do not give in to the temptation to show everything you know about the subject.
- 2) Leave time and opportunity for students to answer each other's questions.
- 3) If you observe that students do not appear to understand the question, you may need to paraphrase it for the benefit of the other students.

Use class time to go over the exercises the students have completed. The sooner they get feedback on their answers, the more learning will take place. Students enjoy this activity as they check their own work. You can save time and ensure fairness by preparing small tokens (cardboard or slips of paper) with a student's name on each. Shuffle the tokens and call students' names in random order, rather than stopping at each question to call on a student with raised hand. This will give every student an equal opportunity to participate and will ensure that students remain attentive. It will also give you an indication of which students do not understand the exercise.

### **Group work**

Many arguments can be made in favor of group work. It allows you to assign different tasks to students with different needs. It stimulates classroom communication since it obliges students to discuss the problem with each other. It fosters cooperative activity which gives students with non-equivalent skill levels an opportunity to interact and learn from each other.

In the typical ESP situation with large classes, inflexible furniture arrangements, and students who are unaccustomed to working in groups, it may not be possible to use group work effectively. Do not feel that you must break the class into groups in order to teach them. Your students may be most comfortable with the lecture format, and if your class session has a variety of activities as suggested above, group work is not necessary for language learning.

However, if you are able to do group work and want it to be most effective, the following principles should be followed:

- 1) When you set a question for the group to focus on, frame the question in several alternative forms to be sure it is understood. Allow sufficient time for thought and be sure students know just how much time they will have ("You've got 5-8 minutes to think about this. ")
- 2) Small groups are best. Have no more than three to five students in a group. Spread the good students out (good students are not necessarily only those who are good in English, but also include those who are good in the content area you are teaching.)

3) Give a short, manageable task (5-20 minutes). Make sure groups know what to do -- ask them to repeat your instructions, say what materials are needed, or outline how they will accomplish the task.

4) Circulate among the groups as they work to be sure groups are on task and to answer their questions.

5) If groups are making class presentations, allow the presentations to continue only until the problem they are working on has been solved. Groups which do not get an opportunity to present on any given day will have an opportunity another day. Do not allow presentations to become dragged out and boring for the other students.

### **Error correction**

Errors are a natural part of second language learning. It is impossible to learn without making errors. Because of this, students' production of spoken and written language is full of errors. The teacher cannot correct every error, and even if it were possible to do so, excessive error correction intimidates the students, decreases their self-confidence and makes them hesitate to use the language. Therefore the teacher must decide how and when errors will be corrected and communicate this policy to the students.

Errors should be corrected only when it can be done without interfering with communication. If you are speaking with a student individually, you should be focusing on the content of what the student is saying, and not on the structure of the language. Error correction in conversation will certainly cause the student to "clam up. " In class recitations, questions which are comprehensible as stated should not be corrected, since this destroys the flow of the interaction and often the real question is lost as the student struggles for grammatical accuracy. Evaluate student responses to your questions according to the results of the response, that is, if the response answers a question on content in a way that is comprehensible, do not make grammatical corrections. When you or other students do not understand a student's question or answer, correction is desirable to get at the intended meaning. And of course, if the purpose of the question is to verify a point of grammar, correction is necessary. This policy can be discussed with the students so that they understand how and when you will make corrections, and soon they will find it natural that not all spoken errors are corrected when they occur.

Writing is the ideal medium for error correction, and most students expect that errors will be corrected in their written work. If on particular assignments you do not plan to correct all errors because you want to encourage students to write extensively without worrying about mistakes, explain this to them so that they realize that what they have written is not necessarily error-free, even if you have not corrected it.

The most noticeable errors a student makes may not be the most important. Errors in article usage, for example, while quite noticeable to the native speaker, do not often interfere with understanding. Focus on those errors which disrupt communication, rather than those which are surface mistakes.

### **Testing**

Testing,-an important aspect of teaching, is, however, often overstressed. Teaching should not be confused with testing, and material which has not yet been taught should not be tested. The purpose of daily classroom activities is learning. Students should not be put on the spot to demonstrate instant proficiency in whatever is being taught.

Appropriate testing will, however, give you an accurate picture of the students' abilities and progress.

A daily comprehension quiz at the end of each class period is a quick way for students to judge their grasp of what has been taught. Such a quiz might consist of five questions which require a yes/no, true/false, or one word answer. This can be given in the last five minutes of class and checked by the students themselves as a closing activity.

Formal examinations should be based on what has been taught in class. Your initial performance objectives can be the basis for test questions. Be sure that the exam relies on the same skills that class activities are designed to build. An oral test, for example, would be a poor test medium if the development of oral skills is not one of the objectives of your program. Use formats that are familiar to students from class activities.

### **Helping students learn outside the classroom**

Your best students will want more from their English program than you are able to provide. They need help in learning how to go about improving their English on their own. You can offer them the following suggestions:

1. Take advantage of every opportunity to have an English language experience: see a movie in English, listen to the radio, go to a lecture.
2. Find a news program on the radio (from the BBC or other source) and listen to it every day. Comprehension will increase rapidly as the daily listening reinforces vocabulary heard previously. If students find that initially they cannot understand enough to benefit from listening, suggest they read the newspaper in their native language before listening to the English. Knowing the big stories of the day in advance will make the radio program more comprehensible.
3. Read for pleasure in English. This point cannot be overstressed. Illustrated English language magazines are available in most parts of the world, and students will benefit from the contextualization they offer. Point out to them that when they read for pleasure they should not focus on understanding every single word; instead they should set their dictionaries aside and strive to comprehend the global meaning of what they read.
4. Take every opportunity to communicate with native speakers of English. Such opportunities include both conversing with native speakers, when possible, and exchanging letters with native speakers. A pen pal can provide good practice in informal writing as well as information about the culture of English-speaking countries.

### **For teachers whose students are U.S.-Bound**

In some cases you may be preparing students for a program of study in the U.S. or U.K. If so, you should incorporate cultural information into your curriculum to help them in their transition. Following are some topics to include:

Greetings and Introduction: Formal and informal situations, when to use first names, how to keep a conversation going.

Punctuality: American standards and expectations. How to apologize for being late. How to talk about time ("it's a quarter after," "it's fifteen minutes " etc.)

Asking questions: Asking for directions or other information.

University life: The U.S. system of education, features of campus life. How to talk with professors and other students.

Food: Common foods, types of restaurants.

Medical care: Vocabulary relating to health and illness, prescription vs. over-the-counter drugs- types of medical care available.

Male-Female Relationships: The roles of men and women in American society; dealing with women and men in all walks of life.

Transportation: Air, bus (inter and intra-city), train, and automobile. How to read a schedule. Driving laws.

Shopping: Types of stores. U.S. money; use of checks, tipping customs.

Other information which your students will find useful includes:

- Geographic and demographic features of the U.S.
- Weather and climate
- The U.S. political system: state and federal government.
- Sports

## **Appendices**

### **Appendix A**

#### *Resources*

There are two categories of books in this Appendix. The first deals with books and a journal which you can use for reference, and from which you can build your professional ESP skills. The second deals with textbooks which can be used either as course books, or sources from which you can develop your own courses.

#### *Reference books*

A. For a background of the evolution of ESP:

John Swales, Episodes in ESP, "Oxford: Pergamon Press, 1985).

This book is a source and reference book on the development of English for Specific Purposes. It aims to both explain and illustrate the major lines of development in ESP. It achieves this by focusing on fifteen landmark publications in the field. Each publication -- eleven articles and four extracts from textbooks -- is analyzed as follows:

1. Setting - The background of the publication and its role in the development of ESP.
2. Text and Commentary
3. Activities - Questions on the text: for example, "Here again is the short "authentic" passage from Example 1. What language work can you derive from it?"
4. Evaluation - Discussion points: for example, " How much say should the students have in the kind of ESP course they get?"

5. Related Readings.

B. For Grammar:

G. Leech & J. Svartvik, A Grammar of Communicative English.

C. For Language and Methodology:

1. Bernard A. Mohan, Language and Content, (Addison-Wesley, Reading, MA, 1986).

A comprehensive treatment of the teaching of language through content. Presents a "knowledge framework" for integrating language and content, giving general principles for organizing information and activities. Useful for the teacher interested in learning theory and program development. Designed as a course text, this book also includes exercises and suggested reading for each chapter.

2. F. Dubin, D.E. Eskey, & W. Grabe, Teaching Second Language Reading for Academic Purposes, (Addison-Wesley Publishing Co., Reading, MA, 1986).

A good introduction to reading theory and the reading process, especially as it applies to the second language learner. Separate chapters discuss reading skills development at the beginning, intermediate, and advanced levels. A section on texts discusses authentic vs. adapted texts and teacher-made lessons. Reading testing and assessment are also discussed. This book is designed as a course text for ESL teachers and contains discussion questions and suggestions for further reading.

D. For an update on what's going on in ESP:

ESPMENA Bulletin.

Published twice a year by the English Language Servicing Unit, Faculty of Arts, University of Khartoum, Sudan. News about research, materials development projects, new courses, and conferences and workshops related to teaching languages for special purposes, especially in the Middle East and North Africa.

E. For Cultural Orientation

1. To the United States:

E. N. Kearny, M.A. Kearny, & J.A. Crandall, The American Way (Prentice-Hall, Englewood Cliffs, N.J., 1984.)

An introduction to American culture, including such topics as "Basic American Values and Beliefs," "Government and Politics," "Education in the United States," "The American Family," and others. Includes vocabulary, comprehension, and other exercise types, questions for discussion and composition, and suggestions for further reading. This book provides useful information about the United States and is richly illustrated with photos, graphs, and charts.

2. To Great Britain:

Britain; 1986, published annually by the Central Office of Information, 49 High Holborn, London, WC1V 6HB. Intended for the use of scholars planning to study in Britain.

A smaller publication, Britain and its People is available from the Kraus-Thompson Organization, Rt. 100, Milwood, N.Y. 10546.



### Course books

The books recommended in this category were selected because of their conceptual endurance, their teaching support, and their emphasis on reading skills. It is unlikely that you will have access to large budgets for buying books, so the ones you do buy will have to last and should be examples of sound, practical teaching based on solid ESP theory. They should also offer stimulation and support to you, the teacher, who will frequently have to develop and adapt the books' ideas and activities. In addition, these books will have to be flexible enough to train students with varying levels of English in their most pressing task of extracting important information from texts written in English.

The books in this category are:

For the sciences:

- A. Nucleus Series
- B. English in Focus

For computer science:

- C. English for Computer Science

For business management and accounting:

- D. Business World
- E. Business Concepts for English Practice
- F. Fluency Squares

For tourism:

- G. Restaurant English
- H. Hotel English

For study skills:

- I. Reading and Thinking in English
- J. Skills for Learning

A. Nucleus Series: English for Science and Technology, C. Barron & D. Stewart, Editors. (Longman Group Ltd., London)

The General Science book in this series has become one of the most successful ESP textbooks ever written, with sales of over one million copies. The Nucleus Series, for which General Science is the core book, originated at a university in northwest Iran. It was written for students entering university with a low level of English, whose medium of instruction at university was not English, and whose main need of the language was to study English textbooks for their science courses.

There are nine titles in the series, including General Science, which can precede or accompany the study of a special subject book. The titles are:

- General Science
- Geology
- Biology
- Mathematics
- Agriculture
- Medicine

Engineering  
Nursing Science

The student's book is accompanied by a teacher's book with notes on methodology and scientific background, together with the texts of listening comprehension passages and answers to the exercises. Each course has a listening cassette containing the pieces for listening comprehension.

All nine of the books have been organized in the same way, following the concepts of form - which includes properties, location, and structure - then process, and finally measurement in each individual subject. In this way the contents pages for Engineering and Biology are almost identical, though students of biology will study the properties and shapes of living organisms, while students of engineering will study the properties of materials.

Each unit is organized into sections of Presentation, Development, Reading and Listening. The simplicity of this organization provides an efficient model which you can follow when you are designing additional material.

The series receives high marks for:

- a. The visuals, drawings, diagrams, charts, etc., which are inventively used to generate language.
- b. The exercises, which are firmly contextualized, either by visuals, or by sentences in the exercise which relate to each other or the text.
- c. The exercises which promote active learning of reading and listening skills, which have often been given a passive role.

The series is criticized for:

- a. The reading texts which are too short and not authentic.
- b. The insufficiently developed reading strategies, which compare poorly with the more sophisticated strategies found in the Focus series.

B. English in Focus Series: J. P. B. Allen and H.G. Widdowson, editors (Oxford University Press, London).

There are eight books in the series:

English in Physical Science  
English in Mechanical Engineering  
English in Workshop Practice  
English in Basic Medical Science  
English in Agriculture  
English in Education  
English in Social Studies  
English in Biological Science

Each of the books in the series follows the same format, with chapters divided into six sections:

- I. Reading and Comprehension
- II. Use of Language
- III. Information Transfer
- IV. Guided Writing
- V. Free Writing

The student's book is accompanied by a teacher's book and cassettes containing recordings of the reading texts and some of the exercises. However, the courses can be taught without these tapes.

The series receives high marks for the variety and number of exercises it offers. The following exercises are particularly useful:

- a. Reading comprehension: Each chapter opens with a reading passage which has comprehension checks inserted in it. Students are encouraged to think about what they are reading by deciding, for example, whether the inserted statement- are true or not, according to the information they have just read.
- b. Rephrasing: After the reading passage, students are asked to replace selected words in the reading passage with listed expressions which have similar meaning. This exercise is useful in developing vocabulary consolidation and search reading techniques.
- c. Information Transfer: This activity uses exercises such as completing paragraphs with information from diagrams. The main regret among both teachers and students is that these exercises are not used more frequently.

The series is criticized for:

- a. The texts which are too short and are too thoroughly worked over. In the process, some students become bored with the repetitious monotony of the exercises' format.
- b. The grammar exercises which are frequently mechanical, and contain sentences which are not related to the reading passage.
- c. The exercises which vary in level of difficulty and which require more explanation than is given.

However, the last two books in the series, Social Studies and Biological Studies, have responded to these criticisms by adding more study skills exercises and by giving more- appropriate explanations where necessary.

C. English for Computer Science, Norma D. Mullen and P. Charles Brown (Oxford University Press, 1983).

English for Computer Science is one of the few books written for the field of computers in ESP. It comes from Canada and was pilot tested among police officers in Kuwait. It is for use by people studying at post secondary institutions who need a reading knowledge of computer science in English.

The course is divided into three parts: The Computer, with descriptions of the characteristics and kinds of computers available; Computer Components, with descriptions of the processor, memory and input/output devices; and Data Processing, with descriptions of programming.

The student's book is accompanied by an answer book, so it can be used as a self-study course.

Chapters with reading passages are followed by exercises interspersed with Focus chapters, (printed in green), which deal with grammar, vocabulary and language functions.

The book receives high marks for the variety of exercises it includes to develop reading skills. For example, there are exercises to promote:

- understanding information directly stated or implied,

- understanding concepts,
- understanding grammatical and lexical devices which bind a text,
- deducing meaning of new lexical items from context,
- scanning to locate specific information,
- distinguishing main ideas from supporting details,
- selecting important points to summarize an idea.

In contrast to the field of computer science, business management has provoked an abundance of ESP courses. Here, three books from the many are recommended to you - two for upper intermediate to advanced level students, and the third for lower intermediate level.

D. Business World: A Collection of Readings on Contemporary Issues, by Roger Speegle and William B. Giesecke, (Oxford University Press, 1983).

This is a collection of articles from prominent American business magazines, adapted for students at upper-intermediate through advanced levels of English as a second language. The aim of the book is to improve business reading comprehension, as well as listening and oral performance.

Each chapter is centered on the reading of an article. The rest of the chapter is divided into business vocabulary, structural review, business communication (summarizing, note-taking, identifying the main idea), action (debating, discussing' interviewing), and reaction (discussing in an open session).

The book receives high marks for:

- a. Using authentic materials. The texts are shortened, but the original sentence structure remains unchanged. Potential problems in understanding vocabulary or the cultural context are dealt with by explanatory notes in the margin. Dealing with these problems in this way saves time and prevents fragmentation of your lesson.
- b. Being lively. The action and reaction sections provoke student participation. While much of ESP's focus is on developing reading skills, students at this level will want to keep up their oral performance skills, and these exercises provide simulated role play situations. The topics chosen for these exercises relate to the text, but are also expanded to include concerns of interest to developing countries. For example:

"The need for environmental protection has created more than 200 new companies in Germany alone. In the U.S., environmental divisions of large companies continue to employ more and more people. Clearly, environmentally related business benefits the economy. Will this sort of business be of interest to businessmen in the developing nations? Where will business in the developing nations be most concerned with investing its money? Do you foresee environmental business becoming an important part of the economy of developing nations?"

The book is criticized for:

- a. The exercises in the structural review, which become predictable and monotonous.
- b. The exercises in business communications, which are insufficiently developed to teach study skills such as note-taking.

E. Business Concepts for English Practice, B. Dowling & M. McDougal, (Newbury House, Rowley, MA, 1982).

This book is intended for intermediate to advanced students of English as a Foreign Language, with an academic or professional interest in the English of business or accounting. The book aims at providing practice in reading comprehension, technical and business vocabulary, and activities

for general language practice and the improvement of study skills. The book was field tested in American colleges and international corporations.

The book has eight units. These unit titles are: Business Basics, Marketing, International Business, Data Processing, Accounting, Finance, Management and Decision Making. Each unit is divided into three parts. The first two parts contain texts followed by exercises, and the third part contains an authentic article excerpted from a journal or newspaper.

The teacher's manual provides additional information on the business and linguistic aspects of the student's book, as well as notes on how to present each lesson.

The book receives high marks for:

- a. The thoroughness of its teaching approach. For example, exercises are preceded by proficiency markers indicating whether the level is for intermediate, upper-intermediate or advanced students.
- b. The comprehensive approach to the subject matter. Both vocabulary and concepts of business and accounting are thoroughly covered.

The series is criticized for:

- a. Failing to exploit the authentic articles more fully.
- b. Being insufficiently international in its approach. Attempts are made to refer to other countries and cultures, but this does not quite balance out the strongly American flavor.

F. Fluency Squares For Business and Technology by Phillip L. Knowles and Ruth A. Sasaki (Regents Publishing Co., 1981).

This book was developed at the Language Institute of Japan, for students with intermediate levels of English who require English training for their work as bankers, engineers and executives. There is little emphasis on the reading of conventional texts; rather, the thrust is towards active listening. This is ESP as in English for Shy Persons, in that students are encouraged to take an active role in their learning, but need not talk much to do so.

The course consists of one book with an answer key at the back. Large scale visuals are also available to facilitate classroom use of the book; however, it might not be too difficult to produce your own enlarged versions of many of the visuals.

The chapter format is as follows:

Oral Presentation of Information, in which the teacher reads the text while students follow visual renderings of the same text.

Oral Practice, in which students are guided in question and answer sessions on the text.

Written Reinforcement; for instance, writing down the questions and answers of Oral Practice.

Dictation

Follow-up Activities, for example, "Make a presentation to your class. Compare two models of cameras, pens, tape recorders, etc. Give your recommendations and the reasons for your recommendations. "

Quantitative English, in which students work with numbers.

## Test

The book receives high marks for:

- a. The careful and attractive layout, and the good use of information transfer exercises.
- b. The emphasis on numbers, graphs, and numerical relations essential to technical communication in any subject.

This book contains no reading passages, and at first this may appear to be a weakness. However, Fluency Squares is directed towards the lower intermediate learner who may well appreciate the use of visuals and numeracy, which provide a non-threatening approach to discussions on concepts of business management. The introduction of basic reading skills from a book such as Concepts in Use, (discussed in the section on study skills, below), could easily follow after.

G. Restaurant English, Philip Gingham, Riitta Lampola, James Murray. (Pergamon Press, Oxford, 1982 U.S. distribution through Alemany Press.)

H. Hotel English, Philip Gingham, Riitta Lampola, James Murray. (Pergamon Press, Oxford, 1982. U.S. distribution through Alemany Press.)

These books are written for students or professionals "who have a knowledge of English, but need to familiarize themselves with the language and phraseology" of hotel management. The books were written with European students of English in mind, but since their target is to teach the English of international tourism, most of the situations covered are applicable to almost any country in the world. The books emphasize listening and speaking skills. For that reason, the books cannot be properly taught without the accompanying cassette tapes.

Restaurant English has fifteen chapters which cover most restaurant situations from paying the bill to discussing special diets customers may require for religious or health reasons. Each chapter follows a format of presenting information, either on the cassette or in the form of menus, table charts or pictures of a place setting for dinner, etc. Each presentation is exploited through a series of comprehension questions, completing sentences or role-play situations.

Hotel English has twelve chapters covering reservations, giving directions, telephoning, handling complaints, and other topics, in a format like that described above for Restaurant English.

These books receive high marks for:

- a. The good exploitation of cassettes as teaching tools. The dialogues are authentic, recorded at "almost normal speed" and with a variety of accents. The two cassettes for each book cover two different levels. The first requires students to listen and reproduce; the second requires students to manipulate the items presented by, for instance, responding to statements.
- b. The emphasis on real-life situations, rather than rigid sets of artificial language exercises.
- c. The inclusion of sets of useful phrases.

These books are criticized for:

- a. The emphasis on Europe, especially when dealing with food.
- b. The sketchy support offered to the teacher in organizing such activities as role-playing or discussions.

I. Reading and Thinking In English, H.G. Widdowson, editor. (Oxford University Press).

This series of four books originated in Latin America in a writing project carried out at the University of the Andes, Bogota, Colombia. The series is designed to "relate ESP with the teaching of more general reading competence", and as such is an example of the study skill materials now coming on the market. The series contrasts with others that have been recommended here in that the focus is on preparation for reading, and not on reading comprehension after the text has been read.

The authors explain the relationship between the four books in the preface:

"The series starts at a near beginner level. It is assumed that the beginning learner has a minimal knowledge of basic grammar and vocabulary...The course then takes the learner progressively through the intermediate stages of language learning by extending his ability to understand the devices of the language and how they are used in academic communication. By the final book he is expected to have developed a sophisticated awareness of the communicative resources of English and an ability to perform a range of challenging reading tasks. "

The four books in the series are:

Concepts in Use (near beginner)  
Exploring Functions (pre-intermediate)  
Discovering Discourse (intermediate)  
Discourse in Action (advanced)

The student's book is accompanied by a teacher's book which contains teaching notes, notes on the units, and answers to the exercises .

The series receives high marks for:

- a. The clarity of its teacher support and the way in which it draws students into the learning process by explaining the learning goals.
- b. The attractive layout, (the books are coded with different colored print), and the full exploitation of the information transfer activities, with many visual cues used to generate language.

The series is criticized for:

- a. The generality of the texts, which attempt to address students from any scientific background, and which frequently end up being too general.
- b. The insufficiency of the vocabulary work.
- c. The inclusion of more discourse analysis discussion than is pedagogically useful.

J. Skills in Learning, Thomas Nelson and Sons, Ltd., Walton-on-Thames, England. (University of Malaya Press).

This series originated at the University of Malaya. It was designed to teach students with little knowledge of English how to extract important information from textbooks and journals written in English. Both this series and Reading and Thinking in English are based on the assumption that it is more cost effective to teach a core of academic language common to most disciplines, rather than to prepare subject-specific materials. However, this series does include one book, Reading Projects: Science, which focuses on texts specifically for students of science. With this book the authors hope to keep the attention of science students.

There are five books in the series:

Foundations

Application

Development

Progression

Reading Projects: Science

The first four books cover a variety of general texts suitable for students with intermediate levels of English. Reading Projects complements the main course books by familiarizing students with the linguistic forms and reading strategies appropriate to the particular subject they are studying. These subjects are geology, chemistry, biology, ecology and-physics. The student's book is accompanied by a teacher's book.

The books receive high marks for:

- a. The explanations and support given to the teacher for organizing classroom activities.
- b. The organized way in which it breaks down study skills into manageable units. For example:

Arriving at main points

Making sense of word behavior

Reading for relevant information

Using contextual clues

Using symbols, abbreviations and equations

Learning about graphs

- c. The variety of exercises it offers. For example:

Checking illustrations. This involves consulting other books and then correcting illustrations which have been incorrectly drawn and labelled.

Writing appropriate headlines for articles.

Checking statements against flow charts, diagrams or graphs.

Putting pictures in the right sequence and then writing subtitles for the pictures.

#### *How to obtain copies of these books*

1. Check to see if the book you want is in the Information Collection and Exchange (ICE) catalogue. If it is, you can either ask your associate director to cable ICE asking for the book, or you can contact ICE yourself. The staff at ICE is willing to help and would like you to take full advantage of the services ICE has to offer. Do not hesitate to contact them if you have any inquiries about materials. For instance, you may want to know what books, other than the ones mentioned in this chapter, are available on ESP in chemistry. ICE can get you a list of titles. Also, you may want photocopies of articles or excerpts from books in the ICE reference section. Again the staff at ICE will be pleased to help.

2. If the book you want is not in the ICE catalogue, you have several options. First, check to see if Peace Corps funds are available for your purchase. If they are, you can work through your country staff. Ways of ordering books vary from country to country, but your associate director will be able to tell you the way he or she has devised. A second option is to ask family or friends to order and pay for.- the book for you. If you check ahead with your country desk officer, it may be possible for U.S. publishers or bookshops to send the book to you via your desk officer. But in this case, remember to ask the publisher to put your name and the country desk clearly on the package. A third option is to order the book yourself.



When writing to publishers:

- a. Ask how much has to be included in the price to cover postage.
- b. Check on the method of payment. The most acceptable are credit cards, international money orders, or U.S. checks for books ordered from the U.S.
- c. Specify whether you want airmail or surface delivery.

In considering how long ordering will take, calculate that from the U.S. it will take two to four weeks to process your order, one week to get the book to your desk officer in Washington, and two to three weeks for the pouch to deliver the book to the Peace Corps office in your country. From Europe calculate two to four weeks to process your order, two weeks for airmail delivery and up to three months for surface mail.

## **Appendix B: Training modules for Peace Corps ESP programs**

### **80 hour pre-service training**

#### **Week One**

##### **Session 1 (4 hours):** The theory of language learning

Reading: Manual Chapter One

What is ESP? Why teach for specific purposes?

- The role of the teacher.
- The task of the student.

Review of approaches to teaching languages

- Grammar/translation
- Direct Method
- Audio-lingual
- Communicative
- Comprehension-based

What modern language teaching theory tells us:

- Developing communicative competence
- Learning vs. Acquisition
- Developing the receptive skills
- The importance of affective variables (motivation, attitude, etc.)

Activity: Ask PCV's to share their individual language learning and teaching experiences and discuss the advantages and disadvantages of various approaches from their personal points of view.

##### **Session 2 (4 hours):** ESP Needs Assessment

Reading: Manual Chapter Two.

Purpose of the needs assessment: Identifying what students need to learn.

Getting to know your institution and colleagues.

Language functions and uses: What to look for.

Getting to know your students: Observing spoken language.

Assessing written materials in the subject area.

Interview techniques for talking with administrators, content-area instructors, and students. Activities: 1) Ask PCV's to construct interview outlines with appropriate questions. 2) Choose a content area and provide examples of the kinds of texts that students of that subject would have to work with. Ask PCV's to identify language functions and uses appropriate to the subject area.

### **Session 3 (4 hours): Teaching Language Skills: Listening comprehension**

Reading: Manual Chapter Three: Listening

"Teacher talk" -- practicing comprehensibility. Incorporating comprehension checks into your lesson.

Helping students recognize clues to meaning in speech.

Exercises which develop listening comprehension.

Activity: PCV's use a visual aid to design a mini-lecture; practice making their speech comprehensible, using "teacher talk" and incorporating comprehension checks.

### **Session 4 (4 hours): Teaching Language Skills: Reading**

Reading: Manual Chapter Three: Reading

What is reading? Getting meaning from print; the role of background knowledge.

Vocabulary development.

Extensive vs. intensive reading.

Assessing difficulty and appropriateness of materials for reading and listening.

Teaching reading techniques: previewing, SQ3R, skimming, scanning.

Recognizing the author's purpose; recognizing patterns of discourse.

Activity: Design and conduct a readability test.

### **Session 5 (4 hours): Teaching Language Skills: Writing and Study Skills**

Reading: Manual Chapter Three: Writing/Grammar and Study Skills.

Building writing skills from sentence to report.

Teaching writing skills: definition, classification, hypothesis.

Teaching library skills.

Teaching note-taking.

Teaching summarizing and avoiding plagiarism.

Activity: Prepare a writing lesson which includes appropriate pre-writing activities.

## **Week Two**

### **Session 6 (4 hours): Teaching Language Skills: Grammar in Reading and Writing**

Reading: Manual Chapter Three: Reading and Writing/Grammar

Using texts for grammar instruction.

Techniques for teaching grammar.

Activity: Prepare a reading or writing assignment; identifying relevant grammatical features for focus and developing a lesson plan for teaching them.

### **Session 7 (4 hours): Teaching Language Skills: Speaking**

Reading: Manual Chapter Three: Speaking

The role of speaking in the classroom.

Developing appropriate speaking activities; the importance of maintaining a communicative emphasis rather than meaningless drill.

Activity: Prepare and demonstrate a lesson which develops speaking skills.

### **Session 8 (4 hours): Course and Materials Design**

Reading Manual Chapter Four

Setting goals and objectives.

Designing a program: Choosing topics and texts.

Using standard formats: making the materials development process easier.

Unit design: incorporating all language skills.

Writing lesson plans: providing a variety of activities.

Activity: Write a unit outline based on a sample text. (This should be considered an on-going process under the supervision of an experienced teaching)

### **Session 9 (4 hours): Materials Selection**

Reading: Manual Chapter Five and Appendix A

Review of resource section of handbook.

Additional sources of materials.

Selecting appropriate authentic materials: features which make materials comprehensible to learners. Authentic vs. "simplified" materials.

Teacher-developed materials.

Activities: PCV's look at a wide array of authentic materials and practice selecting texts appropriate for ESP classes and giving rationales for their choices by identifying features which make the texts accessible and readable. Prepare comprehension exercises for a text you select.

**Session 10 (4 hours): Program Management**

Reading: Manual Chapter Six. Classroom management techniques, including group work and error correction.

Testing and evaluation

Teaching cultural orientation

Activity: Look at test and quiz formats. Design a quiz on the text you have been working with this week.

**Weeks Three and Four**

Volunteers prepare ten lessons for students, including:

- 1) Teaching reading techniques
- 2) Recognizing patterns of discourse.
- 3) A vocabulary lesson.
- 4) Teaching grammar in reading.
- 5) Listening for note-taking.
- 6) Teaching writing
- 7) Teaching speaking: communication exercises
- 8) A study skills lesson.
- 9) A lesson using group work and speaking skills.
- 10) Prepare and administer a test.

**Appendix C: Training modules for Peace Corps ESP programs**

**20 hour in-service training (Ten two-hour sessions)**

**Session 1: Teaching ESP**

<b>Time</b>	<b>Activity</b>
15 min.	Introductions
10 min.	Presentation: Goals of the in-service.
30 min.	Group brainstorming: What is language learning and teaching? Sharing of experiences. Participants report on what has been successful and unsuccessful for them. This sets the stage for the presentation on methods which follows.
45 min.	Presentation: Review of approaches to language teaching; what modern language acquisition theory tells us.
	Review of approaches to teaching languages
	Grammar/translation
	Direct Method
	Audio-lingual
	Communicative
	Comprehension-based
	What modern language teaching theory tells us:
	Developing communicative competence
	Learning vs. acquisition

	Developing the receptive skills
	The importance of affective variables
15 min.	Group work: Why ESP? What are the advantages and disadvantages Groups brainstorm and report See Chapter One for the advantages of the ESP approach.
5 min.	Summary and conclusion.

### Session 2: ESP Needs Assessment

Time	Activity
10 min.	Presentation: Purpose of ESP needs assessment, See Chapter Two.
10 min.	Group brainstorming: Uses and functions of language. What do participants consider important to teach?
30 min.	Group work: preparing for needs assessment.
	Groups construct interview protocols to interview administrators and content-area instructors at their prospective institutions. Groups share results and individuals revise protocols.
20 min.	Presentation and demonstrating observing spoken language. How to identify uses and functions in order to prepare relevant lessons.
15 min.	Presentation: Evaluating written materials. Identifying features to incorporate into teaching materials.
30 min.	Group work: Assessing written materials in subject areas. Give participants samples of subject area materials and have them identify features needed by ESP students.
5 min.	Summary and conclusion.

### Session 3: Teaching Reading

Time	Activity
20 min.	Presentation: Overview of the- four skills. Today's focus on reading. What is reading? See Chapter Three.
45 min.	Presentation and demonstration with sample materials:
	Guidelines for selecting appropriate reading materials. Groups work on selecting and justifying choices.
20 min.	Presentation: techniques for teaching reading.
	Types of exercises. Extensive vs. intensive reading.
	Show examples of exercise types and how they can be used in the classroom to promote reading skills.
30 min.	Groups look at exercise types and make short presentations to the class.
5 min.	Summary and conclusion.

### Session 4: Teaching Listening Comprehension

Time	Activity
15 min.	Presentation: What is listening comprehension? See Chapter Three.
30 min.	Notetaking: clues to meaning. Sample exercise. Give a short lecture. Partners take notes and compare to identify what is necessary for good note-taking skills.
45 min.	Group work: Participants construct listening materials to be used in their classes.
25 min.	Presentation and demonstration: practicing comprehensibility. Teacher talk, comprehension checks.
5 min.	Summary and conclusion.

### Session 5: Writing and Study Skills

Time	Activity
30 min.	Presentation: building writing skills. Sample activities and materials. See Chapter Three.
30 min.	Group work: prepare writing lesson incorporating pre writing activities.

15 min.	Presentation: Study skills. See Chapter Three.
15 min.	Group brainstorming: research skills -- what is needed? Identify features which should be taught.
25 min.	Group work: prepare lesson on teaching study skills.
5 min.	Summary and conclusion.

### Session 6: Teaching Grammar and Speaking

Time	Activity
15 min.	Presentation: How to teach grammar. See Chapter Three.
40 min.	Group work: prepare a grammar lesson in reading or writing which identifies relevant features and shows how to teach them.
15 min.	Presentation: Teaching speaking. See Chapter Three.
15 min.	Group brainstorming: How to encourage speaking in the classroom. Participants share ideas.
30 min.	Group work: prepare a lesson for teaching speaking skills.
5 min.	Summary and conclusion.

### Session 7: Course Design

30 min.	Setting goals and designing a program. See Chapter Four.
10 min.	Demonstration: Sample unit outline.
20 min.	Group work: Writing objectives. Participants write objectives for various skills.
15 min.	Presentation: lesson planning. Using standard formats. Providing a variety of skill practice.
40 min.	Group work: groups select a text and design a unit based on that text. See Chapter Four for model.
5 min.	Summary and conclusion.

### Session 8: Materials Selection.

10 min.	Presentation: Sources of materials. See Chapter Five.
45 min.	Group work: groups review an array of materials and evaluate them in terms of interest, level, and skills addressed. Groups present their evaluations.
30 min.	Presentation and demonstration: developing materials; making materials comprehensible to low-level students. Give guidelines for simplification.
30 min.	Group work: practice in writing materials following guidelines given above.
5 min.	Summary and conclusion.

### Session 9: Program Management and Testing

15 min.	Group brainstorming: Problems you anticipate as you begin your ESP program. Participants present their concerns.
45 min.	Presentation and discussion: Classroom management techniques. Teaching cultural orientation. See Chapter Six. Answer concerns brought out in brainstorming.
25 min.	Presentation: Testing and evaluation issues. See Chapter Six.
30 min.	Group work: groups design a quiz for the unit they developed in Session Seven.
5 min.	Summary and conclusion.

### Session 10: The Total Program

30 min.	Group work: Review of what you will do when you go to your site. Groups develop action plans. Plans should include steps for needs assessment, program development, and materials preparation.
---------	--

20 min.	Groups present plans.
20 min.	Brainstorming: questions and issues in ESP. Final opportunity for participants to raise concerns.
30 min.	Presentation: summary and final words of encouragement.
15 min.	Evaluation of in-service, (Evaluation instrument needed.)
5 min.	Conclusion.

\*U.S. GOVERNMENT PRINTING OFFICE: 1992--619-095/41317