

OUTREACH

*information for
educators and communicators*

Materials on Waste
and Recycling

Peace Corps
Information Collection and Exchange
R0096

Information Collection and Exchange

The Peace Corps Information Collection and Exchange (ICE), a unit of the Center for Field Assistance and Applied Research (The Center), makes available the strategies and technologies developed by Peace Corps Volunteers, their co-workers, and their counterparts to development organizations and workers who might find them useful. ICE works with Peace Corps technical and training specialists to identify and develop information of all kind to support Volunteers and overseas staff. ICE also collects and disseminates training guides, curricula, lesson plans, project reports, manuals, and other Peace Corps-generated materials developed in the field. Some materials are reprinted "as is"; others provide a source of field-based information for the production of manuals or for research in particular program areas. Materials that you submit to ICE become part of the Peace Corps' larger contribution to development.

This publication was reproduced with permission by the Peace Corps Center for Field Assistance and Applied Research. It is distributed through The Center's Information Collection and Exchange. For further information about ICE materials (periodical, books, videos, etc.) and information services, or for additional copies of this title, please contact ICE and refer to the ICE catalog number that appears on the publication:

Peace Corps
Center for Field Assistance and Applied Research
Information Collection and Exchange
1111 20th Street, NW - 5th Floor
Washington, DC 20526

tel.: (202) 692-2640; fax.: (202) 692-2641

Share Your Experience

Add your experience to the ICE Resource Center. Send your materials to us so that we can share them with other development workers. Your technical insights serve as the basis for the generation of ICE manuals, reprints, and training materials. They also ensure that ICE is providing the most up-to-date, innovative problem solving techniques and information available to you and your fellow development workers.

OUTREACH

Materials on Waste and Recycling

Issue 91: Global Problems, Local Solutions

Issue 92: Conserving Natural Resources

Issue 93: Recycling

Issue 94: What to Do About Hazardous Waste

Issue 95: Learning-By-Doing Leaflets on Waste
and Recycling



Reprinted with permission of OUTREACH

Peace Corps
Information Collection and Exchange
June 1995
R0096

How to use OUTREACH packs

The materials in OUTREACH packs may be used for **non-commercial, educational purposes in low-income countries**. Use the material as you wish:

ADOPT all or part of the materials for inclusion in articles, activities and programmes;

ADAPT materials to make them have local relevance;

ADD materials to existing articles and programmes to complement local interest with more general interest.

Write for more information to contributing organisations or those listed in resource sections.

Whatever way you use the OUTREACH pack, **PLEASE CREDIT SOURCE** where indicated. Otherwise please credit OUTREACH.

Who can use OUTREACH packs

The OUTREACH packs are supplied free-of-charge to 'multipliers' in low-income countries. 'Multipliers' are people who can pass on the environment and health messages to a wider audience. They include:

- * *newspaper journalists* who can use the materials:
 - as 'fillers' in newspapers and magazines;
 - in articles;
 - in a series of articles;
 - in special editions, especially in children's health and environment newspaper supplements and magazines.
- * *radio broadcasters/journalists* who can use the materials:
 - as 'spots' between programmes;
 - in reports;
 - in a series of programmes on a specific issue;
 - in a special programme devoted to a particular topic;
 - as background information for interviews with local experts on environment and health issues.
- * *community workers and representatives from Non-Governmental Organisations (NGOs)* who can use the materials:
 - to inform their own networks;
 - as background information for programmes;
 - for meetings and activities with women; farmers; scouts, girl guides and other youth groups; community groups and leaders;
 - in environment and health campaigns;
 - in training workshops.
- * *teachers* who can use the materials:
 - for background information for their own classes;
 - for classroom activities;
 - in teacher training workshops;
 - on field trips and in laboratories;
 - in curriculum development.

What you can do for OUTREACH

We need feedback on the packs. How useful is this material? How can we make it better? Are there special topics you need? Please let us know. Please send us material to which you have added OUTREACH materials. We can pass it on to others to help them in their projects.

We also want to hear about the projects you are working on, and see the materials you

produce. We would like to pass on your information and ideas to others in the OUTREACH Network. Please write to:

**Dr. James Connor, OUTREACH Director, Teaching & Learning Center,
200 East Building, 239 Greene Street, New York University, New York NY
10003, USA or**

**Mr. Richard Lumbe, OUTREACH Co-ordinator, Information & Public Affairs,
UNEP, P.O.Box 30552, Nairobi, KENYA**

ACKNOWLEDGEMENTS

These OUTREACH packs were written and edited by Gillian Dorfman.

OUTREACH would also like to thank Mary Appelhof (Flowerfield Enterprises), Sandra Cointreau, Dr. John W. Reynolds and Heather Spalding (Greenpeace) for their assistance in the preparation of the OUTREACH packs on waste.

Issue 91

Waste part 1: Global Problems, Local Solutions

CONTENTS

	Page(s)
Location map	iv
How to use this pack	v
Urban waste in rich and poor countries	1-2
Waste and recycling in Third World cities	3-7
Enduring litter	8
Trash trek	9-11
How some communities have tackled waste problems	12-14
Clean Up the World	14-18
Clean Up the World	18-19
Clean Up the World Events, 1993	20-23
Happy beach, sad beach	23
How garbage is collected and managed in one favela in North East Brazil	24-26
Turning garbage into gardens in Porto Novo, Benin	26-27
Turning garbage disposal into jobs for women	27-28
Thai schoolchildren tackle waste	28-29
Fun and games with a serious purpose	30

LOCATION MAP

The map below shows the location of countries mentioned in OUTREACH issue no. 91:

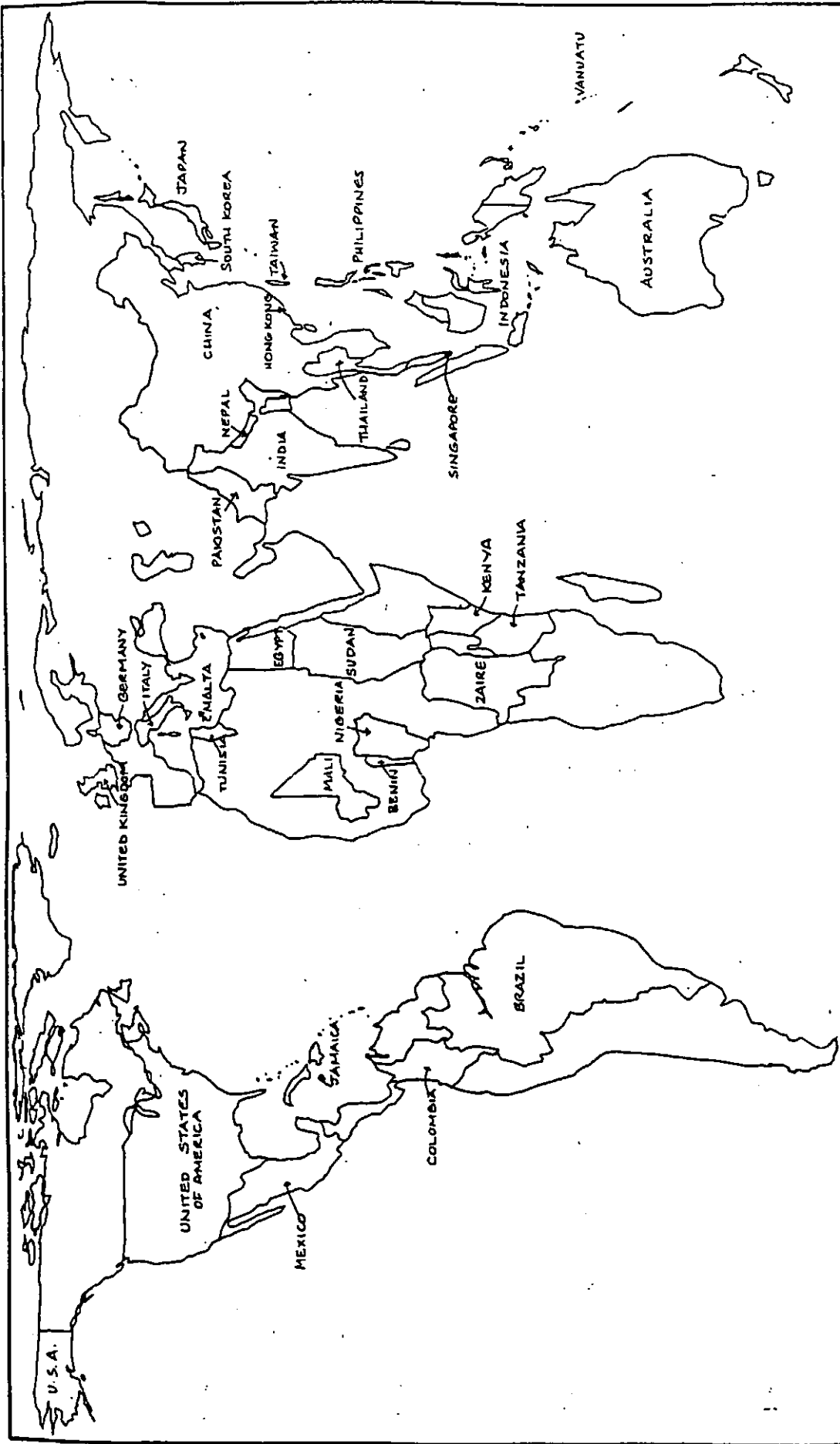

USEFUL CONVERSIONS FACTORS

linear measurements: 1 in. = 2.54 cm. 1 yd. (36 ins) = 0.91 m.

square measurements: 1 acre = 0.42 Ha. (1 km.² = 100 Ha.)

weights: 1 long ton (2,240 lb) = 1.02 metric tonnes

1 mile (1 760 yd) = 1.61 km.

1 sq. mile (640 acres) = 259 Ha.

1 short ton (2,000 lb) = 0.91 metric tonnes (1 metric tonne = 1,000 kg.)

How to use this OUTREACH pack

Issue 91: Waste part 1 - global problems, local solutions.

This pack is the first in a series of five OUTREACH packs that explore waste and recycling. It looks at the type and scale of waste problems that exist, particularly in Third World cities and towns, and emphasises the growing recognition of the need to develop local solutions to match local needs and opportunities. Much of the pack is devoted to local case studies to illustrate the variety of ways waste problems are being - and can be - tackled in order to inspire others to act to improve their local environments. It also draws attention to the Clean Up the World campaign that is attempting to focus international attention on the problems of rubbish while encouraging individual and group action.

Other packs in the waste and recycling series include three more general packs and one Learning-By-Doing leaflet pack:

92: Conserving natural resources; 93: Recycling;
94: What to do with hazardous waste; 95: Learning-By-Doing leaflets on waste and recycling.

At the beginning of each segment there are suggestions as to how the material might be used by multipliers. Here are some general suggestions:

- **Community workers and school teachers** might use the material on Clean Up the World Campaign to get ideas for local projects that they can help to initiate as part of the global campaign. Their local projects can be publicised through radio and the local press, and **journalists** can draw upon material in this pack (pages 12-23) for general background on the Clean Up the World Campaign.
- **Journalists** might write newspaper articles on local municipal waste problems, drawing attention to what local communities are trying to do about the problem. Pitfalls - such as local authority bureaucracy - and success stories could be highlighted. Journalists might draw upon the global information on pages 1-7 to put local issues into perspective, and also use examples of how similar obstacles have been overcome in other communities.
- **Community workers** might be inspired by case studies described in this issue (pages 12-14 and pages 20-23) to start a recycling or other waste disposal campaigns.
- **Radio broadcasters/journalists** might use this pack to provide them with background information (e.g. pages 1-7) before interviewing local experts and/or politicians on a local waste issue.
- **Teachers** might use the story "Trash Trek" (pages 9-11) as an introduction to project work on waste. Discussions about this one view of the future with future decision-makers might jolt them into action. The examples of what Thai children are doing (pages 28-29) might give the students a few ideas about where to direct their energy.
- **Journalists and/or radio journalists** might use the information and ideas presented in pages 92-94 to produce a series of articles or programmes on waste. For example a series could look at "Employment opportunities in the waste business" drawing on the following material: 91: pp 24-28; 92: pp 20-27; 93: pp 8-12; 94: pp 21-23; 95: leaflet nos. 75-80)

Urban Waste in Rich and Poor Countries

SOURCE

The following article is based upon information in *World Resources 1988-89*, a report by The World Resources Institute and The International Institute for Environment and Development in collaboration with the United Nations Environment Programme (Basic Books, Inc., New York, 1988)

The international statistics are from *Environmental Management of Urban Solid Waste in Developing Countries: A Project Guide* by Sandra J. Cointreau (The World Bank, Washington, D.C., 1982). While these statistics are from a 1982 report, a telephone interview with the author confirmed that the figures remain valid.

If reproduced, please acknowledge original sources.

SUGGESTIONS FOR USE

Teachers: As part of an introduction to projects on consumerism, waste, urbanisation or development.

Journalists, radio broadcasters: As background information for articles/scripts aimed at increasing awareness of the global waste problem.

Children's newspaper supplement/magazine writers: As a source for graphics on waste issues.

How much waste do people throw away?

When living standards rise, people consume more -- and waste more. The chart below illustrates that the more wealthy a country and city, the more waste urban dwellers tend to generate:

Urban Waste Generation Rates^a

City or country	kg./person/day
<i>Industrialised countries</i>	
New York City, USA	1.80
Hamburg, Germany	0.85
Rome, Italy	0.69
<i>Middle-income countries</i>	
Singapore	0.87
Hong Kong	0.85
Tunis, Tunisia	0.56
Medellin, Colombia	0.54
Kano, Nigeria	0.46
Manila, Philippines	0.50
Cairo, Egypt	0.50
<i>Low-income countries</i>	
Jakarta, Indonesia	0.60
Surabaya, Indonesia	0.52
Bandung, Indonesia	0.55
Lahore, Pakistan	0.60
Karachi, Pakistan	0.50
Calcutta, India	0.51
Kanpur, India	0.50

Source: Sandra J. Cointreau, *Environmental Management of Urban Solid Waste in Developing Countries* (The World Bank, Washington, D.C., 1982), Table 1, p.10
Note: ^a For cities in developing countries where the total refuse mix was divided into major categories of waste, data indicate that the residential portion of the total refuse was 60-80 percent.

Among the industrialised nations, Americans are by far the world's biggest waste makers. New Yorkers hold the world record for producing the most garbage per person. They each throw out three times as much rubbish each year as residents of Manila, in the Philippines.¹

Cities in middle income countries -- Cairo, Manila, Tunis and Hong Kong, for example -- generate 0.5 to 0.85 kilograms per person per day. In a city of 1 million, this rate produces 500 to 850 metric tons of waste each day. Large cities in low income countries -- such as Calcutta, Karachi and Jakarta, for example -- generate 0.5 to 0.6 kilograms of waste per person per day.

Solid waste disposal in growing secondary cities can also be a serious problem. In Morocco, for example, the urban waste collected ranges from 107 tonnes a day in Marrakech to more than 963 tonnes in Casablanca. But generally, people in smaller cities in both more developed and less developed countries generate less waste primarily because they have fewer commercial activities than larger cities.

What waste do people throw away?

What people throw away depends upon where they live. In industrialised countries, packaging contributes about 30 percent of the weight and 50 percent of the volume of household waste. Food and yard scraps account for most of the remainder. Paper constitutes by far the largest share of packaging, followed by glass, metals and plastics. Every American discards almost 300 kilograms of packaging each year.²

People living in cities in industrialised countries tend to throw away little organic material and a high percentage of paper, plastics, glass and metals, see table below. For example, the trash of residents of New York City, USA, contains valuable metals, reusable glass containers, recyclable paper and plastic and food waste high in nutrient value. It also contains ever greater amounts of hazardous wastes - mercury from batteries, cadmium from fluorescent lights, and toxic chemicals from cleaning solvents, paints and wood preservatives.³

In less developed countries, a large part of urban household waste is vegetable and putrescible materials, including human faeces.

Urban Waste Composition

(percentage by weight)

Material type	Industrialised cities			Middle-income cities					Low-income cities			
	Brooklyn, New York, USA	London, England	Rome, Italy	Singapore	Medellin, Colombia	Lagos, Nigeria	Kano, Nigeria	Manila, Philippines	Jakarta, Indonesia	Lahore, Pakistan	Karachi, Pakistan	Calcutta, India
Paper	35	37	18	43	22	14	17	17	2	4	<1	3
Glass	9	8	4	1	2	3	2	5	<1	3	<1	8
Metals	13	8	3	3	1	4	5	2	4	4	<1	1
Plastics	10	2	4	6	5	X	4	4	3	2	X	1
Leather and rubber	X	X	X	X	X	X	X	2	X	7	<1	X
Textiles	4	2	X	9	4	X	7	4	1	5	1	4
Wood, bones, straw	4	X	X	X	X	X	X	6	4	2	1	5
Nonfood total	74	57	29	63	34	21	36	40	15	27	4	22
Vegetative and putrescible	22	28	50	5	56	60	43	43	82	49	56	36
Miscellaneous inerts	4	15	21	32	10	19	22	17	3	24	40	42
Compostable total	26	38	71	37	66	79	65	60	85	73	96	78

Source: Sandra J. Cointreau, *Environmental Management of Urban Solid Waste in Developing Countries: A Project Guide* (The World Bank, Washington, D.C., 1982) Table 3, p.14

Notes: Figures may not total due to rounding.

X = not available

Other sources:

1. Sandra J. Cointreau, *Environmental Management of Urban Solid Waste in Developing Countries: A Project Guide* (The World Bank, Washington, D.C., 1982)
2. Cynthia Pollock, "Realizing Recycling's Potential" in *State of the World 1987, a Worldwatch Institute Report on the Progress Toward a Sustainable Society* (W.W.Norton & Co. New York and London, 1988)
3. Environmental Defense Fund, *To Burn or Not to Burn: The Economic Advantages of Recycling Over Garbage Incineration in New York City* (New York, 1985)

Waste and Recycling in Third World Cities

SOURCE

Adapted from *The Poor Die Young: Housing and Health in Third World Cities* edited by Jorge E. Hardoy, Sandy Cairncross and David Satterthwaite, published by Earthscan Publications Ltd. (London, 1990), 120 Pentonville Road, London N1 9JN, UK, and from 'Living with garbage: Cities learn to recycle' by Sandra Cointreau and Maarten de Kadt in *Development Forum* (Jan.-Feb. 1991) published by the United Nations/DPI (New York, USA). If reproduced, please credit original sources.

SUGGESTIONS FOR USE

Teachers, Community workers: As background information to increase awareness on waste issues in the Third World.

Journalists, Radio broadcasters: As the basis of a script for radio; as a source of information for newspaper articles to increase awareness on the subject; as background information for interviews with local experts commenting upon local waste situations.

Third world cities and towns are growing fast. More than 1.3 billion people live in urban centres in the Third World. There are now more urban dwellers in the Third World than there are in Europe, North America and Japan combined. While the number of rural dwellers still exceeds the number of people living in urban areas, countries are becoming increasingly urban societies. Virtually all Third World governments have failed to cope with the rapid urban growth.

The result? An escalation in the number of people living in overcrowded dwellings and in informal and illegal settlements with inadequate or no services such as water, sanitation, and refuse collection.

The questions and answers below look at the issue of waste and recycling in Third World cities today. Part 1 looks at what's happening with waste and recycling, and Part 2 explores some ways to move forward.

PART 1: WHAT'S HAPPENING WITH WASTE AND RECYCLING?

Q. In general, what services exist for solid waste disposal in Third World cities?

A. Waste collection services in developing countries reach only from 50 to 80 percent of urban populations. The box on the next page illustrates the inadequacies in garbage collection in different cities. Typically, there are too few collection trucks available to do the job. Lack of money for spare parts means trucks are not available for long periods. On any given day 15 to 50 percent of a fleet may be needing repairs and cannot be used.

Q. Why is so little household waste collected?

A. Several reasons, not least the cost. Solid waste disposal is a large expenditure for cities of all sizes, and the costs increase with city size. Costs also vary with the type of disposal method used. For example, littering and dumping cost a municipality virtually nothing, and engineering filling of small depressions and channels and burning of open dumps are relatively inexpensive. But these options pollute the environment and create human health hazards. Sanitary landfills with daily cover are more costly, and environmentally safe incineration is an expensive means of disposing of urban solid waste.. Many cities in less developed countries now spend over 30 percent of their budgets on refuse collection and disposal.

Q. What happens to uncollected garbage?

A. Uncollected garbage is highly visible in most cities of the developing world. Wastes are dumped on streets and on open land, in drainage ditches, rivers, streams and lakes.

Q. Does this create health problems?

A. Indeed. The health problems are obvious. Piles of garbage are scattered by scavengers or animals and serve as food or breeding grounds for rats and flies. Dangers to health arise from the germs in the refuse itself and from the disease-carrying creatures which breed or feed there. Uncollected refuse often clogs drainage channels, which then become stagnant pools and may

Inadequacies in garbage collection in a selection of Third World cities

The following cities were selected simply because data was available. Several of them seem relatively well-served compared to many cities which could not be included here for lack of accurate data:

Bangkok, Thailand: Although 80 percent of the population is served by a refuse collection service, in 1987, around a quarter of solid waste generated in the city remained uncollected and was dumped, mostly onto vacant land or in canals and rivers.

Jakarta, Indonesia: Around 30 percent of the garbage is not

collected, and ends up in rivers and canals, and along roadsides where it clogs drainage channels and causes extensive flooding during the rainy season.

Karachi, Pakistan: Only one-third of the solid waste produced in the city is removed.

Dar es Salaam, Tanzania: Only a quarter of the city's refuse is collected.

Kinshasa, Zaire: Household waste is only collected from a few residential areas. In the rest of the city, household waste is dumped on roadsides, on illegal dumps, in stormwater drains or buried on open

sites.

São Paulo, Brazil: One-third of the population lives in areas with no service to collect household wastes.

Bogota, Colombia: Around half the 1.5 million tons of garbage generated every year is collected and disposed of by local authorities. Every day, some 2,500 tons of wastes are left uncollected - some are partially recycled informally while the rest is simply left to rot in small piles or in canals, sewers or the streets.

Source: Jorge E. Hardoy and David Satterthwaite, *Squatter Citizen: Life in the Urban Third World* (London: Earthscan Publications, 1989)

overflow. If drainage channels are carrying liquid wastes which includes excreta, this can further contaminate land and seep into groundwater supplies, increasing the risks to all residents. Uncollected garbage is particularly hazardous to children who play on streets. It is also a fire hazard.

Q. Who suffers the most from inadequate waste disposal services?

A. Poorer households usually suffer most. It is overwhelmingly the poorer areas of the city which have inadequate or no services to collect garbage. And poor people generally do not have the space in their homes to store garbage, or the space or means to have rat- and dog-proof dustbins outside their homes.

Q. Why do poor households have inadequate refuse collection services?

A. There are several reasons. Firstly, so many poor people live in settlements regarded as illegal by public authorities. This means their right to public services is often not acknowledged. Even if their right is recognised, there are likely to be limited resources to pay for services. Garbage collection is the responsibility of local municipal governments, and the poorer households live in the poorest municipalities, which have the least resources for public services. This is especially so where revenues generated in richer city districts are not transferred to help pay for services in poorer districts. The collection and disposal of solid wastes is expensive. It often consumes as much as 20 to 40 percent of a municipal authority's total budget.

Secondly, poorer areas of a city are often more expensive to service. Many poor settlements are built on steep hillsides and on other terrain that is not accessible by vehicles. Houses are often built close together linked only by narrow paths. Thus is it difficult to get conventional garbage-collection trucks into the settlements.

A third reason is that poor people throw away less waste which can be profitably reclaimed by refuse collectors, or by the scavengers or recycling businesses with which the refuse collectors deal. Private companies can make money so long as they collect garbage from richer neighbourhoods where service charges can be higher and where rubbish contains more valuable recyclable materials.

Q. So some of the waste is recycled?

A. Yes. People in developing countries are recycling not as a way of disposing of rubbish, but is a means of earning a living. Most major cities in the Third World have thousands of households

that rely on incomes they make by reclaiming material from household garbage for resale. Some make a living collecting wastes by going door-to-door in residential neighbourhoods. Others sort through rubbish once it has been collected, or when it is unloaded at the official city dump.

The numbers of individual street buyers, collection workers and dumpsite scavengers involved in recycling represent 1 to 3 percent of the urban population in developing countries. There are more than 10,000 dumpsite pickers in Mexico City, and more than 7,000 door-to-door collectors who privately run the city's recycling system. Waste piles in Cali, Colombia, a much smaller city, supply 400 well-organised workers with saleable scrap.

Q. What do these people do with the materials they collect?

A. In general, recycled materials are bought from scavengers by dealers who sell to industry. In some cities, there are buy-back (redemption) centres where recycled materials can also be turned in. In Bangkok, for example, there are about 1,000 licensed dealers privately operating buy-back centres. Dealers also buy directly from commercial and industrial sources.

Q. Is recycling a profitable business?

A. The people from whom the dealers buy make only a meagre living. Dumpsite scavengers usually make only enough to feed themselves on a day-to-day basis, and only if whole families work at the dump is there enough money for more than essential food requirements. Usually, the only people who make a significant income from recycling are the dealers who mark up selling prices from 50 to 100 percent over their buying prices.

Q. What materials are recycled?

A. There are many different kinds of materials that are recycled -- paper, scrap metal, plastics, glass and so on. But there is one common requirement of all recycled material: it must have a commercial resale value. In many cities, there are hundreds of businesses, ranging from small family-based enterprises to large-scale firms which manufacture all kinds of goods out of reclaimed materials. Many industries are dependent on recyclable materials because there are no domestic supplies of raw materials, and the imported ones are expensive or unobtainable.

Q. Can industries save costs by using recycled materials?

A. Yes. Indeed, savings in materials costs for industries can be substantial. For example, a 1988 study in Bangkok, Thailand, showed that recycling led to savings on materials costs of 75 percent in the paper industry and 10 percent in the glass industry. A 1985 study in Cairo, Egypt, showed that plastic manufacturers saved about 50 percent on materials by using recyclable materials. A 1983 study in Peru indicated that recycling led to an annual savings of about \$20 million in foreign exchange.

Q. Do industries save on fuel bills, too?

A. Yes. Many industries use recyclable materials to cut down their fuel bills. Energy costs can be substantial in developing countries that depend upon imported fuel. So it makes sense to produce goods from recycled materials which use less energy than to produce goods from new raw materials. In the Bangkok study, it was estimated that recycling led to savings of 25 percent in the paper industry and 20 percent in the glass industry. In 1984, the Chinese city of Shanghai estimated that it had reduced industrial fuel requirements by the equivalent of 15 million tons of coal during the past 25 years of recycling.

Q. If recycling waste provides a living for so many people, is good for business, and helps dispose of waste, then is the level of recycling high in the Third World?

A. Actually it is not high. The amount of waste recycled in most Third World countries ranges from 1 percent in a number of African countries to 10 percent in several Latin American and East Asian countries. However, there are a few exceptions. In Cairo, Egypt, 22 percent of solid wastes

is recycled - about 14 percent is privately recycled by the source, and the other 8 percent is recycled after being discharged into the waste collection system. In Mexico City, an estimated 25 percent of the wastes is recycled after being discharged into the waste collection system - 5 percent by refuse collection workers and 20 percent by dump scavengers. Furthermore, there is a government-assisted waste exchange programme in Mexico City by which additional recycling is done between industries through exchange agreements.

Q. Why is the level of recycling generally so low?

A. Recycling tends to take place only where there is an industrial demand. If there is no demand, there is no incentive to recycle. In Nigeria, for example, thousands of abandoned cars cluttered roadsides until a steel mill, designed to use scrap ferrous metal, was constructed. In Mexico, dumpsite scavengers in some cities may or may not recover plastics, depending upon the proximity of plastic manufacturers.

How can garbage be collected when municipal budgets are limited? How can services be provided to the poorer, more inaccessible settlements whose inhabitants are least able to pay for services but who are in most need? How can the health problems faced by those making a living from garbage be addressed? How can recycling initiatives be encouraged? Solutions need to be found. Part 2 looks at new approaches to dealing with waste and recycling.

PART 2: THE WAY AHEAD

Q. What can be done about the solid waste problem in Third World cities?

A. New approaches to waste management need to be adopted. This requires changes in attitudes from certain professionals. This is already happening. In the book, *The Poor Die Young: Housing and Health in Third World Cities* edited by Jorge E. Hardoy, Sandy Cairncross and David Satterthwaite, Stenio de Coura Cuentro and Dji Malla Gadji describe attitudes that are beginning to - and should - change.

Firstly, there is a growing recognition of the need to develop local solutions to match local needs and opportunities. Conditions vary so much from city to city, for example, in the type and scale of refuse generation, the type of collection vehicles required, local possibilities for recycling, local traffic conditions, availability of land sites for city dumps resources available and so on. New solutions are likely to be very different from those taught to engineers whose training is overwhelming based upon western techniques.

Secondly, there is a recognition that different garbage collection vehicles suit different settlements. For example, carts pushed manually or modified bicycles might be more appropriate for some locations.

Thirdly, there is a growing realisation that the cheapest and most effective way of collecting refuse is to involve local residents in the planning and management of refuse-collection schemes. This is especially so when materials are to be reclaimed or recycled: these schemes lead to additional employment, and help cut down the volume of waste that needs to be disposed of.

A fourth change in attitude is that scavengers, rag pickers and recycling businesses are valuable elements of a waste management scheme, and need to be supported, not treated as nuisances. Authorities tend to look upon the scavengers involved in recycling as a nuisance, upon the buy-back centres as an eyesore, upon the time spent by refuse collection workers in recycling as unproductive, and upon the shantytowns housing dumpsite scavengers as an embarrassment. Instead, there should be an appreciation of the material and energy costs saved by industry, of the benefits to nations' trade balance and of the savings of waste disposal costs.

A final change in attitude among professionals is the appreciation of the links between garbage collection and other improvements in infrastructure and services. For instance, paving roads to and within settlements can reduce collection costs while, in turn, improved garbage collection means fewer blocked drainage channels and thus less water pollution.

Q. What are some of the measures that national governments can take to assist recycling efforts?

A. To increase the level of recycling, developing countries may need to increase their industrial base. Not only would an increase in the industrial base affect industrial demand for recyclable materials, but it would increase price competition. Currently, because there is too little competition among industries in most developing countries, the prices paid for recyclable materials are low.

Governments can also provide technical and financial assistance in establishing the initial network for a waste exchange and waste recovery. To provide support and limit duplication of efforts, national governments could provide a major service by setting national goals, researching and developing recycling markets, examining technologies for materials recovery and reuse, and developing financial arrangements which support local efforts.

Publicity provided by governments about the successes and failures of existing programmes would diminish unnecessary duplication of local efforts.

Q. What innovative efforts have already been made?

A. Effective ways of disposing of urban solid waste, especially in smaller cities and towns often involve public partnerships. Private organizations provide services that local government cannot offer efficiently and effectively on their own, or private firms supplement local government services. In the central region of eastern Sudan, for example, the Regional Ministry of Health contracts with private organizations employing sweepers with donkey carts to collect dry refuse and garbage house-to-house in small towns. This system is more efficient and less costly than buying expensive imported garbage trucks, and some of the costs could be recovered through household charges.¹

In 'Living with garbage: Cities learn to recycle' by Sandra Cointreau and Maarten de Kadt in *Development Forum* (Jan.-Feb. 1991), several innovative recycling schemes are described:

- * In Indonesia, door-to-door buyers have formed cooperatives with the support of central and local governments. Once united into cooperatives, buyers of recyclable materials are more empowered to obtain fair prices from dealers who buy recyclable materials on industry's behalf. Also, they are able to pool their resources to purchase equipment which enables them to better meet industrial specifications and thus obtain higher prices.
- * In Egypt, with financial help from the World Bank, the community of waste recyclers which performs much of the city's waste collection through private arrangements, has received upgraded community infrastructure (that is, water, drainage, roadways) and improved collection and waste processing equipment.
- * In the Philippines, with the help of the central government, cottage industries have been established to recycle wastes into new products. The government assisted the new companies in networking with sources of waste, and also in finding markets locally and overseas for their recycled products.
- * In Korea, scavengers at open dumps have been provided with sturdy housing, clean water and bathing facilities.
- * In Mexico, increasing numbers of specially-designed sanitary landfills feature a designated area for waste recovery that enables scavenging to take place after trucks unload and before waste is buried.

Other Sources

1. M.A. Lewis and T.R. Miller, *Public-Private Partnership in African Urban Development* (U.S. Agency for International Development, Washington, D.C. 1986)

Enduring Litter

SOURCE

Reprinted from *The No Waste Anthology: A Teacher's Guide to Environmental Activities K-12* produced by California Department of Toxic Substances Control, Public Education Unit. If reproduced, please credit original source. *The No Waste Anthology* is a compilation of interdisciplinary, action-oriented, cooperative problem-solving activities focusing on pollution prevention. Produced in 1991, the publication is divided into three sections: natural resources and pollution, solid waste and hazardous waste. For further information, write to: California Dept. of Toxic Substance Control, P.O.Box 806, Sacramento, CA 95812-0806, U.S.A.

SUGGESTIONS FOR USE

Teachers: As an introduction to classwork on litter and its impact on the environment.

NGOs, journalists, radio broadcasters: As statistics to heighten awareness of the problem of littering.

Litter at the roadside is ugly. How long it will stay before decaying may be an ugly surprise.

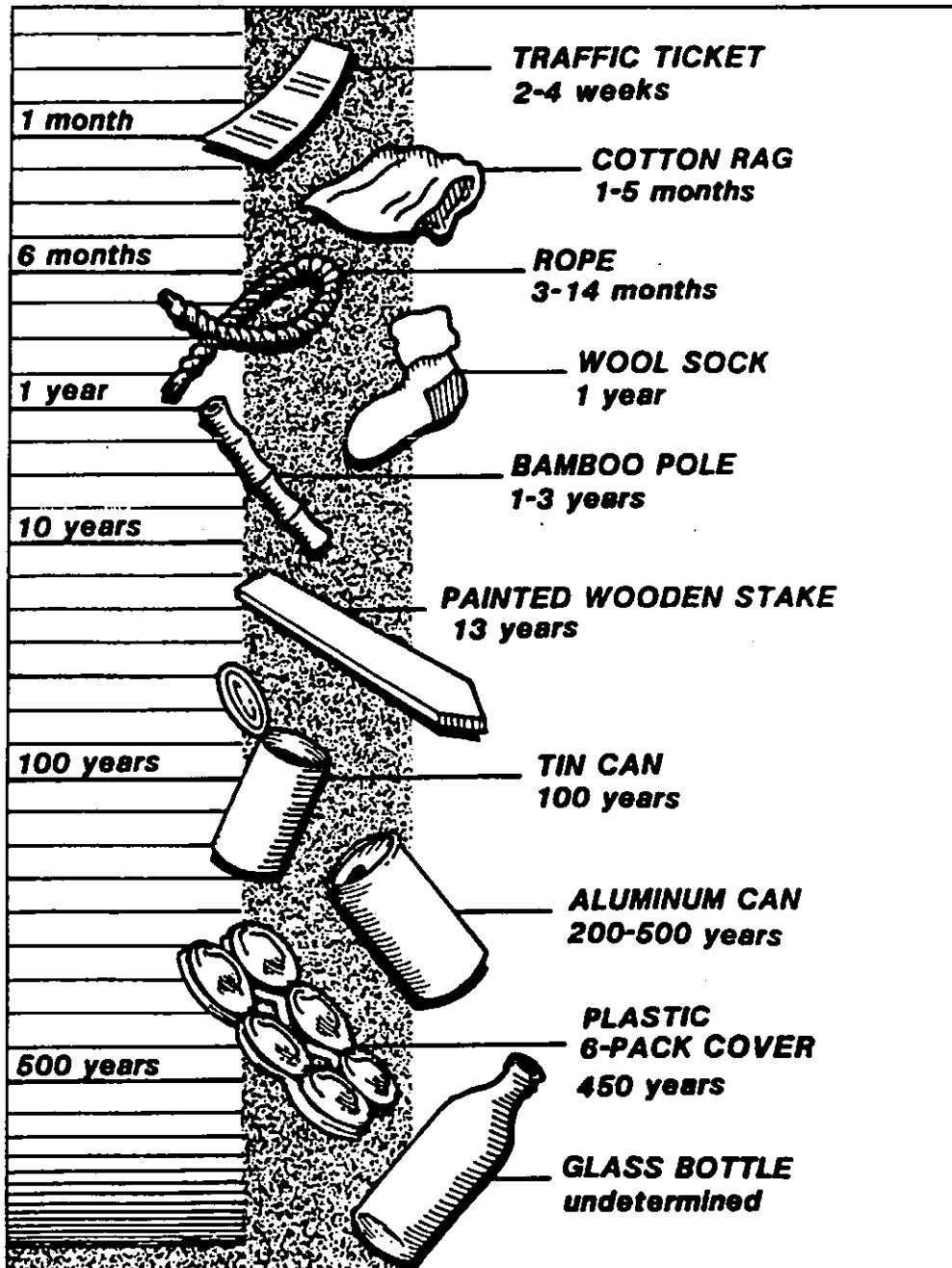

Trash Trek

by Deborah Churchman

SOURCE

The following story is adapted from the September 1990 issue of *Ranger Rick* magazine, with permission of the publisher, the National Wildlife Federation. Copyright 1990 by National Wildlife Federation. For further information, contact Gerald Bishop, Editor, *Ranger Rick*, National Wildlife Federation, 1400 Sixteenth Street, N.W., Washington, D.C. 20036-2266, U.S.A.

SUGGESTIONS FOR USE

Teachers, Community workers: As a story to read to the class/youth group followed by class/group discussion and activities.

Radio broadcasters: As a story to read over the air.

Children's newspaper supplement/magazine writers: To adapt/reprint. (Copyright permission would have to be sought from NWF.)

Wiping sweat off her forehead, Pat stooped and fingered the sooty dirt of an almost blank planet. It didn't look promising. Her space pod had nearly run out of fuel, and the other ship was more than a light year away. Pat needed to find something -- anything -- in this solar system to power the pod. Her map said the system's third planet had once been home to intelligent life. So she'd set the pod in orbit around it and beamed down.

Standing back up, she looked over the rolling land. Weird mushrooms and slimy moulds sprouted between the hills. The blue-green thing in the distance looked as if it might be a lake. *At least I can breathe*, Pat thought, inhaling the heavy air.

She poked her chemical analyser into the ground. It showed loads of methane gas below the surface. *The ship could use that as fuel!* she thought. *Now how do I collect it?*

Pat wandered over the sooty hills, punching at the soil occasionally with her boots. Suddenly, the soft, grey soot just ahead sank into a gaping hole. The hole swallowed her up and pulled her down! She hurtled through the ground, tumbling along a hot, bumpy tunnel. Finally, Pat landed on something soft. It was black, plastic -- and full of garbage. *That looks just like an antique trash bag*, Pat thought, amazed.

All around her, more trash bags were propped up along the walls and floor -- almost to the ceiling of the large tunnel. A dark, oozy liquid dripped down the tunnel walls, making everything slimy. The heat was unbearable, and the odour was worse. Pat longed to run away from this filthy place. *Will my transporter work in this hole?* she worried as she reached for her

gadget.

It was gone! Somehow the transporter had slipped from her belt during the fall. Turning her laserlight, Pat dug frantically for the transporter among the trash bags. The methane gas in the air was making her gasp and stumble. Pat wished her life support pack hadn't run out of oxygen. *I must find some air!* she thought. *Then I'll come back and find the transporter.*

Pat knew she couldn't climb those slimy walls to the surface. The tunnel was dimly lit by a kind of glowing fungus, so she turned off her laserlight to save power. Then she started sliding down the tunnel, stumbling dizzily over squishy, spilling trash bags. Just ahead, she heard a bubbling sound. *Is that water?* she wondered.

Turning the corner, Pat saw a dark green stream. The smelly, disgusting liquid bubbled across the tunnel. *Pyoo*, she sniffed. *This place is disgusting!*

Beside the stream was the strangest being Pat had ever seen. But what got Pat's attention was the thing he was holding. It was a tank, the kind scuba divers once used on her home planet. *Air!* she thought, running towards the creature.

The creature was using this tank to pump up an inner tube. The tube was part of a makeshift boat.

"Please," Pat gasped, clutching her throat. "The tank. I need air."

The creature, who'd been watching Pat from the corner of his eye, looked up. "Need some of this stuff, do you?"

Pat nodded.

"Well then, there goes my boat." He took the nozzle off the inner tube and passed it to Pat.

She stuffed the nozzle into her mouth and took a deep breath.

"Thanks," Pat said, taking another swig of air. "I owe you one."

"Oh, no problem. We're all in this together, eh? Us against the Insizors!"

"What are Insizors?" Pat asked.

"You're not from here, are you?" the creature said. "They're big critters. Some call them mutant rats. Meat-eaters, with sharp teeth. So where are you from?"

"Far away," Pat told the creature. "My name is Pat," she said, trying to shake the creature's clawed hand.

"Mine's Scabby," said the creature, staring at Pat's hand. "Glad to meet you."

"What's this place called?" Pat asked.

"Trashland," the creature said. "You from another landfill or something?"

"Sort of," Pat said. *He'll never believe me if I say I'm from outer space*, she thought. "I'm from far away," Pat said again. "And I need to get back. But I need methane gas for my, um, car. And I need to find my...box," Pat said.

No trouble," the creature said, smiling. "Lots of methane and boxes around here."

"I lost a little black box with buttons. It fell down back there when I...arrived."

"H'mmm... may have slipped to the next level," the creature said. "One of the other Trashpickers will probably find it. We'll go to the power plant first -- where we collect methane. The Thinkers there know how to turn it into electricity."

Pat had trouble keeping up with the creature through the trashy, slippery tunnels. And she had to watch out for the fallers -- heavy objects that crashed through the ceiling without warning. When Scabby got bonked by an old radio, Pat noticed, the radio just bounced off his head. *So that's why Scabby's head is so super bony*, Pat thought. *But why are his feet so big?*

In the next moment she discovered why. They came to a big mound of plastic bags. Scabby leaned forward and zipped away on his long, strong feet. He looked as though he was skiing. Pat lost her balance as she slid behind him.

"Your big feet come in really handy," Pat said, landing in a towering pile of grass clippings.

"Tell me -- how do you stand living here?"

Pat asked Scabby.

"You get used to it," Scabby said. "You can get used to anything, you know."

Pat stared at him. *I hope not*, she thought. *I'd hate to get used to this place.*

As they went along, Pat noticed a really terrible smell. She stood still, sniffing the air. "Something smells really weird."

"What do you mean, smells?" Scabby asked. Pat stared at him. The creature's nose had only tiny holes. *So that's how he can stand these terrible odours*, she thought.

Pat sniffed again. "I smell smoke."

The creature's eyes widened. "Watch out!" he yelled, tugging Pat away from the pile of dried grass. "It's going to flame!"

Pat hurtled straight down the tunnel, landing in a huge wad of chewing gum. A noise like an explosion shook the tunnel. Then a wave of mega-heat hit them. "It's a quickfire!" the creature shouted as flames crackled. "You run ahead. I'll get us some crawlers."

Pat obeyed, yanking gum off her boot as she hobbled along.

A short while later, Scabby caught up with her. He was carrying a handful of roasted cockroaches. "Good munchy crawlers, eh? Here -- take a few. I got plenty."

"Actually, I'm not hungry," Pat said. Turning, she asked, "How much farther to the power plant?"

"Right down the Junkfoam tunnel," the creature said, pointing to the right.

Walking carefully along a tunnel paved with fast-food burger boxes, Pat and the creature entered a room lit with an eerie green glow. The room was rigged with a turning, churning, noisy wall of machinery. In the centre of the room were more creatures, arguing over a pile of old machines.

"Hi, Thinkers -- meet my new friend," said Scabby. "Needs methane for a car."

The creatures looked Pat over very carefully. Finally one spoke: "You've got a car?" she asked. Pat nodded; the space pod was a bit like a car. "Wow!" said the Thinker. "The tunnels must be super-big where you live. Well, take as much as you like -- the collector's over there," she said, pointing to a wall-size machine.

The machine backed onto a big tank. *It must suck in methane*, Pat thought. *How in the world did they rig this up?*

The creatures were still arguing about the machines. Suddenly, one whispered, "Uh, oh -- what's that?" Each creature whirled around, listened, and dived for cover behind broken furniture and appliances. Pat heard nothing, but she decided to hide, too.

Then it came -- the biggest rat Pat had ever seen. *Must be an Insizor*, Pat thought. It was as big as a lion! And the monster-rodent was heading straight for Scabby!

Pat pulled out her laserlight and shouted, "Hey Insizor!" The Insizor turned towards her. Pat punched the button, and set off a brilliant light.

The Insizor screamed in rage at the blinding flash. The Thinkers all jumped out of their hiding places and ran towards the rat. Using old rope, used fan belts and twisted plastic wrap, they tied the Insizor into a tight ball. "Throw it into the quickfire," one of the Thinkers said. "There'll be much meat tonight!"

A short, skinny creature entered the power plant just as two Thinkers hauled out the rat.

"Who bagged the Insizor?" he asked.

"Scabby's new friend," said one of the Thinkers, pointing to Pat. "Used a new kind of light-maker. What's happening with you?" he asked the creature.

"Got some kind of zapper here," said the creature, pulling out a black box with buttons. "But I can't seem to puzzle out how the thing works. Thought you could poke at it."

Pat looked at the zapper. It was the transporter!

"That's mine!" she said, reaching for the black box. "I lost it when I first came -- my friend will tell you." Scabby nodded. The other creature just stared.

"I'll make you a deal," said Pat. "If you give it back to me, I'll give you my laserlight." She showed the creature her gadget, turning it so he could see. The creature still held the transporter. "And my special pills that make the water

drinkable," Pat added.

"Yuk -- who'd want to drink water?" a Thinker asked. "It's so filthy."

"Where I live, we drink a lot of water. It's clean and sweet," Pat explained. "You can even swim in it. And in the evening, deer and rabbits come down to the water's edge to drink. It's a beautiful place...."

"Sounds pretty weird to me," said Scabby. "But maybe you're used to it. Anyway, this is yours." Scabby grabbed the transporter and handed it to Pat. Pat handed over her laserlight and a package of pills.

"You know," said Scabby, "listening to you, I'm remembering a story my great-grandmother handed down about our world."

Pat, carefully setting the coordinates on her transporter, aimed the collector's methane towards her pod's fuel tank. *Sure hope this works*, she thought, hitting the Start button. *Zap* -- the pod's tank was full! Now Pat turned to Scabby and smiled. "What was the story?" she asked him.

"Nana said Trashland was once bright and colourful, too," said Scabby. "We drank water and put our whole bodies into it, I think. The air was light, and there was something called a sky. But then the trash came. Tons of it, piling up year after year..."

Pat, making changes with the transporter buttons, got ready to beam up. But what Scabby said reminded her of something.

"Say -- I think something like that happened to my people, too," she said. "But most of them left the planet when the trash took over. Well, it's time for me to go."

"There was a name," Scabby said, mumbling to himself. "Not Trashland. Our world had an old, old name. What was it?"

"I've got to go now," Pat said, punching the beam button. "I've got to get home."

"Hey, I remember!" the creature shouted as Pat disappeared. "It was Earth! The name of our world was EARTH!"

Activities

1. Draw a picture of Scabby, the Thinkers and the Insizor based upon their descriptions in the story.
2. *Trashland Trek* describes one vision of Earth in the future. Tell a story that describes what you think Earth of the future will be like.
3. Make a list of things we can do now to prevent Earth from becoming Trashland.

How some communities have tackled waste problems

SOURCE

Clean Up the World - How To Do It: A guide to organising community clean-ups prepared by Clean Up the World Pty Limited, 123 Harris Street, Pyrmont, Sydney NSW 2009, Australia. [tel: (61 2) 692 0700; fax: (61 2) 692 0761]. Original sources are noted below. Please give credit to Clean Up the World/appropriate original source.

SUGGESTIONS FOR USE

Teachers, Community workers, NGOs: As ideas for inspiring local clean-up action.
Radio broadcasters, Journalists: To make their audiences aware of how various groups have tackled urban waste problems.

Nairobi, Kenya

Mathare Valley in Nairobi, Kenya, is a poor neighbourhood that faces high rates of disease and death, a major cause of which is uncollected garbage and blocked drainage ditches. The Mathare Youth Sports Association proposed a programme in which the young people of Mathare can participate in sports organized by the Association free of charge in exchange for carrying out garbage and drainage ditch clean-

ups. In the programme, the clean-ups are scheduled with the games, and sports teams earn additional points in their league standing for taking part in the clean-ups. A community service cup is awarded annually for the best performance.

Source: Project Proposals, Mathare Youth Sports Association, Box 69038, Nairobi, Kenya

Malta

The Ministry for the Environment in Malta has developed a cartoon character called Xummiemu (pronounced Shoom-mee-moo), a cleanliness-loving hedgehog, to help community education programmes. Media advertisements have depicted Xummiemu cleaning up different locations, including beaches, roadsides and parks. These campaigns have been very successful in promoting anti-pollution action in Malta and Xummiemu is now a household name. On occasions an actor has dressed up as Xummeimu and visited clean-up locations to give moral support to volunteers.

Source: Environment Secretariat, Ministry for the Environment, Floriana, Malta

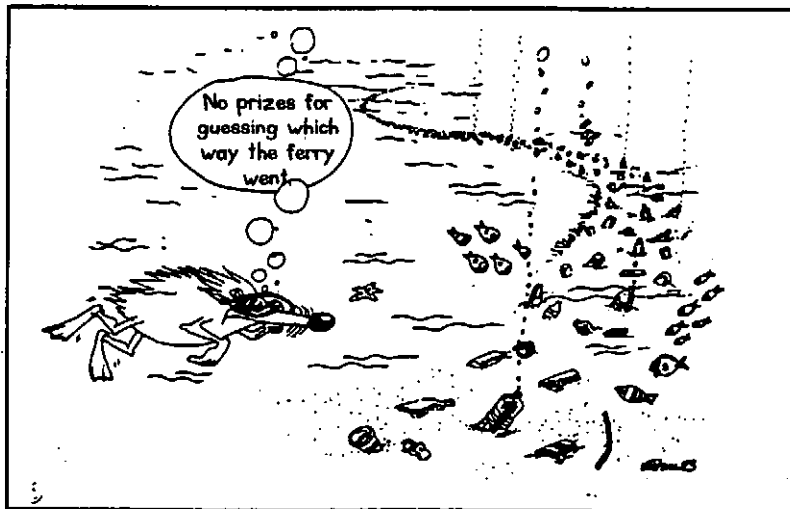

Gulf of Thailand

A group of volunteers operate a pollution patrol of the western shore of the Gulf of Thailand by light aircraft. They are concerned

about the shore, the fishing grounds, forests and swamps along this area which are often not easily accessible by land. They report on

industrial polluters, and any badly polluted area in the hope that this will act as a preventive measure and preserve the natural habitat.

Source: Pollution Patrol by Ultralight Aircraft, Department of Industrial Works, Bangkok, Thailand.

Curitiba, Brazil

In 1990, the City Council of Curitiba, Brazil, calculated how much it would cost on a per bag basis to hire a company to clean up the informal dumps in its shanty towns (favelas). Then, it launched a "Don't Throw Away Your Garbage - We Buy It" programme that offered an equal sum of money per bag of garbage to the residents of the favelas to clean-up the many open-air waste pits which had become breeding grounds for disease-carrying rodents. Under the programme, every person was provided with a much sought-after free public transit ticket for each bag of garbage they delivered to a municipal collection truck. This was a big incentive as the favelas were located at some distance from the city centre and public transport was the only means for residents to commute. The City also donated a certain amount of money for each bag collected to a neighbourhood association for use in community projects, such as community gardens. The

immediate impact of the programme was a marked reduction in the rate of disease. Areas which were once piled high with garbage were transformed into urban gardens or were reforested.

In 1991, the City enhanced the project. With a declining economic situation in Brazil, the consumption of fruit, vegetables and dairy products dropped. The City was able to buy surplus food directly from producers close to the city at a very low price and offer the residents a 4kg bag of food in exchange for a bag of garbage. This reduced the waste of good food and increased the disposable income of poor families, enabling them to spend money on other necessities. The programme also assisted the local farm economy and boosted the nutrition of families in the favelas.

Source: Instructions for a Sustainable Future by International Council for Local Environmental Initiatives (ICLEI), 1992.

Banbung, Indonesia

The City Council of Banbung, a city on the heavily populated island of Java, Indonesia, found the burden of waste collection and disposal had become overwhelming. Dumping sites in the central city had become overcrowded and waste had to be transported away from the city. Squatter communities or "kampungs" did not have adequate roadways for the formal collection of rubbish, and informal dumps had grown in these areas creating major health hazards. Squatter residents, especially children, who depended upon the selling of recyclable and reusable materials from roadside dumps, were seen as a hinderance to the formal waste disposal system.

In an attempt to find a solution, the City of Bandung has developed, with a non-governmental organization working in the city, the Integrated Resource Recovery System (IRR). In the IRR programme, residents of squatter

communities work together in a more formalized programme to separate recyclables from the city's waste stream. This provides a low-cost alternative to taking all the waste to already overstretched landfill areas. It also recognizes the value "scavengers" have in dealing with the waste disposal crisis.

A researcher living with the squatter families, identified social services that families would need for them to become productive recycling cooperatives: evening schooling for children, health care and assistance on the development of a savings and loan cooperative corporation. Providing these and other financial and technical support enabled residents to improve their recoverable waste services, and to develop a business infrastructure to compost organic wastes properly. (78% of the waste stream in Bandung is composed of organic materials.)

The IRR programme created business and

employment opportunities using waste products as raw materials and "capital", which in turn has influenced the setting of fair prices for the secondary materials collected. It provided the residents with a sound economic and social base, one that was recognized locally and owned by the residents themselves. From this base other non-recycling enterprises developed.

In the three years since the programme began operating, the number of families involved in the programme has grown from 35 to 88. The sorting and selling of waste for recycling has intensified. Organic compost is made and sold. Some compost is used for intensive urban farming for the family members' needs. Seeds collected from the waste are used in seed farming. All shelters and dwellings have been improved, and

a food market has been set up to supply daily needs. Health, maternal and child care programmes have been introduced in cooperation with the Municipal Health Department. Savings have grown from US\$108 to US\$1080.

Bandung anticipates that within 10 to 15 years, the current solid waste management system will be converted to a collection of waste-managing IRR communities, given the proper market conditions for their solid waste "products" and given the growth in the population of the city. The IRR approach has been adopted by two other Indonesian cities.

Source: Instructions for a Sustainable Future by International Council for Local Environmental Initiatives (ICLEI), 1991.

RADIO TRANSCRIPT

Clean Up the World

SOURCES

1. A United Nations Environment Programme radio script written and presented by Richard Lumbe and Lucy Mulenkei and produced by Beatrice Lacoste, 1993. The script is part of a series of UNEP scripts that deals with topical environmental problems. For further information, contact IPA, UNEP, P.O. Box 30552, Nairobi, KENYA (tel: (2542) 230 800; fax: (2542) 226 831)
2. A Clean Up the World press release. For further information, contact Clean Up the World, 123 Harris Street, Pyrmont, Sydney NSW 2009, Australia [tel: (61-2) 692 0700, fax: (61-2) 692 0761].

SUGGESTIONS FOR USE

Teachers, Youth Leaders: As information to increase awareness about garbage, and to inspire students to take action.

NGOs, radio broadcasters, Journalists: As source material to encourage local action to clean up rubbish.

Presenter 1: Just what is the environment?

Many people think of spreading deserts, forests threatened by the fuel wood crisis, and lakes, rivers and oceans polluted by industry. But as the number of city dwellers increases, our environment is also urban. Streets, playgrounds, city parks and harbours. As our industry grows, cities in developing countries face the problem of coping with domestic wastes. Such as plastic which is not biodegradable and phosphates from washing powder.

According to the United Nations Environment Programme, the amount of municipal waste in developing countries is fast catching up with that in industrialized countries. In just thirty years, the quantity of refuse doubled from about 160 million tonnes in 1970 to 322 million tonnes in 1990.

Presenter 2: Indeed, and to make things worse, in most developing countries, sanitary services are not enough; in fact, most urban centres in Africa and Asia have no sewage system at all. Most human and household wastes end up in rivers, streams, canals, gullies and ditches. In addition, refuse collection services are inadequate or non-existent in most residential areas of cities in developing countries. An estimated 30-35% of solid

wastes generated within urban areas is left uncollected. It accumulates on streets, on open spaces between houses and on wasteland.

Presenter 1: When garbage is left uncollected and not properly disposed of, it poses many dangers to the people. Such untreated refuse, particularly in hot climates, creates a breeding ground for disease vectors and pathogens. The environment in and around human dwellings offers fertile areas in which fleas, cockroaches, bugs, mosquitoes, flies and other insects can thrive. These insects transmit a variety of diseases, the most common being diarrhoea and malaria. Diarrhoea claims 5 million children each year, measles 2 million, tetanus 1.8 million and malaria 1 million. This is a very serious situation which must be addressed by all.

Presenter 2: This is why UNEP has been promoting a Clean Up the World campaign. The campaign offers an opportunity to highlight the problems of garbage worldwide, and to encourage people to take an active part in tackling the problem. The campaign was launched on the weekend of September 17-19, 1993.

Presenter 1: With around 30 million participants in 79 countries, Clean Up the World has become a landmark in environmental history. In its first year, the campaign has shown that it has the potential of reaching many, many millions of people in all parts of the world. It brought together communities from the farthest-spread corners of the Earth in the world's first ever unified effort at making an inroad into rubbish pollution. The positive achievement for the environment is immeasurable.

Presenter 2: The campaign has added to the impact made by the hundreds of thousands of individuals already involved in community clean-ups.

Presenter 1: There is an awareness that garbage is a problem all over the world. The challenge comes from mobilizing communities to do something about it. What gives us optimism is that communities have already started doing something about garbage disposal. I will give you some examples. Scouts and Girl Guides in many countries carry out clean-ups as part of their communities activities. There are several international organizations which also undertake clean-up activities. For example, the Center for Marine Conservation, which is based in the USA, coordinates beach clean-ups every September in more than 60 countries worldwide. Then there is the Children's Alliance for Protection of the Environment which has branches in 40 countries and also promotes beach clean-ups every September. Small national groups also promote clean-ups.

Presenter 2: Yes, and the Clean Up the World campaign is helping to unite all these groups so that they can work together to achieve their common objectives. There is a strength in numbers, and when different groups join forces to tackle the common problems, then much more is achieved than when they work independently. In short, there is a need to bring clean-up resources together; there is also a need to mobilize other resources; and finally, there is a need to employ all these resources in an on-going, long-term clean-up programme.

But how do we do this? What is the strategy to mobilize these resources? How does one go about organizing a clean-up?

Presenter 1: The approach differs from situation to situation, depending upon the nature and the magnitude of the problem. Clean Up the World has produced a "How to do it" kit to

help those who need ideas. There is also a regular newsletter to report on the progress of the campaign. Perhaps, I should tell you about the experiences of two organizations, one in a developing country and the other in an industrialized country to give some idea of how it has been done elsewhere.

Presenter 2: Yes, it is a global problem. It is easy to understand that the way to tackle the difficulties of a city-clean-up must be different in different parts of the world. Please give us some examples!

Presenter 1: I'll start with the Australian experience. It all began in 1986 when Ian Kiernan, a housebuilder and yachtsman was competing in the world yacht race. While out in the open sea, he was dismayed by the amount of garbage in the world's oceans. So great was his concern that he resolved to do something about it, and what better place to start than right at home, in his own backyard, so to speak. He rallied a committee of friends and relatives and together they organized a clean-up of Sydney Harbour on Sunday 8th January, 1989. Forty thousand volunteers turned up and more than 5,000 tonnes of rubbish were removed. The success of that clean-up led to the creation of Clean Up Australia, an organization to promote clean-ups in the country. It also led to the creation of an annual Clean-Up Australia Day. To date, more than one million Australians have participated in clean-ups. Clean Up Australia committees, which are made up of volunteers, operate in more than 500 cities and towns around the continent, and the movement is growing each year. Clean Up Australia has produced a report on the garbage situation in the country. They have also published a "How to do it" kit with a video and a booklet describing what individuals can do to recycle, re-use and reduce garbage.

Presenter 2: I must say that is quite impressive. One individual making such a difference! This Australian really acted like a catalyst, a spark setting the whole engine in motion!

Presenter 1: Ian Kiernan and Clean Up Australia did not stop there. They approached UNEP with the idea of Clean Up the World. That's how the world campaign came about. Now for the developing country experience. When Kim McKay, a director of Clean Up Australia visited the United Nations Environment Programme in Nairobi, Kenya in February 1989, she talked to a group of non-governmental organizations about the Australian clean-up movement and the global campaign. Kim wanted to see if the City of Nairobi would join the Clean Up the World campaign.

Presenter 2: So that is how it all started! People including children with rakes, shovels and large plastic bags collecting garbage.

Presenter 1: Indeed, those attending the meeting were much encouraged and motivated by what they heard, and by what they saw on video. In February 1992, the Kenya Scouts Association convened a meeting of several NGOs at which it was agreed to form a loose coalition called Clean Up Nairobi which would operate under the auspices of the Kenya Scouts Association.

Presenter 2: But why a loose coalition? It seems to me it would be more meaningful to form an organization like Clean Up Australia, with an office and full-time coordinator.

Presenter 1: As you said earlier, different places require different solutions. The founder members of Clean Up Nairobi were primarily youth organizations: scouts, girl guides, wildlife clubs and other youth environmental NGOs, all with few resources. They also wanted

to participate freely, without tying themselves down or losing their individuality.

Presenter 2: What happened after that?

Presenter 1: Clean Up Nairobi contacted other organizations to join and support them. The first was the Nairobi City Commission because it is important to have the support of the local government authority. After all, clean-ups complement the work of the local authorities. Then, organizers approached industry and asked for assistance with logistics -- transport, implements such as shovels and wheelbarrows, and other items needed for clean-ups.

Presenter 2: How did the organizers divide up the work?

Presenter 1: Three task forces were set up. The first dealt with logistics, specifically to identify what was needed; the second was sponsorship, to seek the logistical support needed; and last but not least - the publicity task force to generate awareness about the need for clean-ups and publicize the activities of Clean Up Nairobi. One of the first things the coalition did was to draw up a time line -- a list of things to be done, when and by whom. The first clean-up took place on 11th July, 1992. With the help of member organizations and the City Commission, sites were identified in 15 estates in the City. The City Commission and commercial garbage removal companies provided trucks and bags to remove the refuse. Industry assisted with additional implements. The Kenya Broadcast Corporation, which was represented on the publicity task force, assisted with publicizing the campaign.

Presenter 2: Do you think the Clean Up Nairobi campaign was successful?

Presenter 1: Certainly. More than 3,000 volunteers turned up. This was quite an encouraging beginning. However, it could have been better, and the experience gave Clean Up Nairobi new ideas on how to do it next time. For example, the organizers felt communities could have been more effectively organized and they have since started to look into the question of engaging local mobilizers, individuals within the community who can assist. A clean-up will not be successful if residents in the area are not fully involved.

Presenter 2: We learned that Clean Up Nairobi should go into a long-term public awareness programme focussing on the management of household wastes as this would eliminate some of the illegal dumping in the estates. What else did we learn?

Presenter 1: Clean Up Nairobi would also like to promote waste recycling programmes at household and community level. An Awareness programme for schools and a "Cleanest School" competition would also help to spread the message. Most importantly, Clean Up Nairobi would like to focus part of its public awareness campaign on the issues of human health and the environment -- to show communities that incidences of diseases such as malaria and diarrhoea which are common in the poorer sections of the society are linked to the state of the environment.

Presenter 2: Please tell us how much money is needed to undertake all this work? What financial arrangements have the organizers made for its activities?

Presenter 1: You would be surprised but Clean Up Nairobi does not raise funds for any of its activities. What the coalition does is to ask members to contribute what they can, in

cash, by underwriting any expenses incurred, or by providing services in kind. The same approach is used for sponsors. It has worked well so far.

Presenter 2: The Clean Up the World campaign helps us to focus on this important issue, and gives us the opportunity to mobilize our communities to do something about the garbage problem, especially in developing countries.

Presenter 1: There is a role for everyone to play in Clean Up the World! If you need further information on Clean Up the World, or how you can start clean-up activities in your community, please write to: The United Nations Environment Programme, P.O.Box 30552, Nairobi, Kenya.

This programme has been produced by the United Nations Environment Programme, and from your presenters, it's goodbye.

QUESTIONS AND ANSWERS



SOURCE

Clean Up the World - How To Do It: A guide to organizing community clean-ups prepared by Clean Up the World Pty Limited, 123 Harris Street, Pyrmont, Sydney NSW 2009, Australia. [tel: (61 2) 692 0700; fax: (61 2) 692 0761]

SUGGESTIONS FOR USE

Teachers, Community workers, NGOs: As a starting-point for local clean-up action.

Radio broadcasters, journalists: To make their audiences aware of the international campaign.

What is Clean Up the World?

Clean Up the World is a campaign designed to focus international attention on the problems of rubbish and waste affecting the state of the world's environment, and the importance of the role that individuals play in improving their own local area.

Clean Up the World is a unique opportunity to unite communities around the world in an activity to demonstrate concern for our local environments. At the same time, by participating in clean-ups, people can create immediate results and permanent changes in their local areas.

What is a clean-up?

Clean-ups are carried out by groups of volunteers working together in their own communities to make that community a cleaner place in which to live. Volunteers work together to remove garbage from designated areas, taking care that disposal of that garbage is managed in a responsible manner. Clean-ups should be enjoyable activities that encourage people to take greater care of their community areas on an on-going basis.

What kinds of areas can be cleaned up?

The sites are often public areas such as beaches, waterways, park land, markets and roadsides, and are chosen by local organizers.

Are clean-ups just one-day events?

They need not be. They can serve as catalysts for permanent changes in attitude and behaviour,

and encourage the adoption of practices, such as recycling, that can have a profound effect on waste management in the community.

Who can participate?

Any community can participate. And within a community, a clean-up campaign can bring together individuals, local government, industry, business, schools, community and civic groups.

How do we get involved in Clean Up the World?

Start by writing to Clean Up the World at its headquarters at 123 Harris Street, Pyrmont, Sydney NSW 2009, Australia [tel: (61-2) 692 0700, fax: (61-2) 692 0761]. This office oversees the coordination of the campaign and the international promotion of the event, and is the chief liaison point between Clean Up the World and each local Organizing Committee. A small permanent staff prepares and distributes information to assist each Organizing Committee plan and promote local clean-ups. The regional Offices of the United Nations Environment Programme also assist with information and distribution of materials.

What kind of materials?

The most useful publication to help you get started is *Clean Up the World: HOW TO DO IT*. The information in this booklet is intended as a guide to organizing a community clean-up. As it would be impossible to produce a definitive guide suitable for communities in every part of the world, the *HOW TO DO IT* guidebook has been written in a generic manner, and is primarily based upon Clean Up Australia's experience in developing and promoting successful clean-up campaigns for the past several years.

The information in the booklet should be seen as only a foundation upon which a local Organizing Committee can plan and manage a clean-up that is suited to local conditions and resources. As the publication is being used by people all over the world in very different cultures and countries, with very different priorities and considerations, the guidebook has been written as a series of suggestions from which the Organizing Committee can take ideas and learn from the experiences of other people that have held similar activities. Then, the Committee can decide what it wants to do locally. It is the responsibility of each Organizing Committee to ensure proper planning and conduct of the clean-ups in its village, town or city.

What suggestions does the guidebook make?

The guidebook outlines 6 steps to a clean-up operation:

1. *Setting up an organizing committee* which is responsible for the management and conduct of each clean-up. Responsibilities might include securing sponsorship or services, decisions and planning regarding the size and locations of areas to be cleaned, organizing the removal of rubbish, coordinating promotion and encouraging volunteers in the general public.
2. *Planning*. This covers the selection of clean-up sites; the choosing of one or two site supervisors for each site, and defining their responsibilities; the planning of ways to encourage and register volunteers; safety precautions; the provision of collection containers; the organization of communications; the securing of support of community groups; the arrangements for waste removal and disposal; the involvement of schools in the campaign and in associated educational activities.
3. *Your clean-up day*. Advice is given on setting the day and time for the voluntary clean-up; on what supervisors and volunteers should bring to the site; on how to cope with emergencies.
4. *Promotion and Publicity*: The booklet covers ways to make locals aware and enthusiastic about the clean-up(s); how to deal with the media; ways to promote the event in the community.
5. *Sponsorship and funding of your clean-up*. Likely expenditures are noted and ideas for raising funds are mentioned.
6. *Working towards long-term changes*. Ways to use the one-day event to focus attention on the need for individual behavioural changes and waste management changes on the part of community organizations.

The booklet offers suggestions for recycling and composting, and includes some case studies of successful clean-up programmes to provide inspiration and ideas to others.

Clean Up the World Events, 1993

SOURCE

Clean Up the World Campaign reports. Please credit original source. For more information, contact Clean Up the World Pty Limited, 123 Harris Street, Pyrmont, Sydney NSW 2009, Australia. [tel: (61 2) 692 0700; fax: (61 2) 692 0761].

SUGGESTIONS FOR USE

Teachers, Community workers, NGOs: As ideas for inspiring local clean-up action.

Radio broadcasters, journalists: To make their audiences aware of how various groups have cleaned up rubbish in their communities, and to inspire them to take action in their own communities.

Below are just some of the first year's country reports on the Clean Up the World campaign:

Indonesia

The Clean Up event began on the evening of 17th September, 1993, with community gatherings in five locations throughout Jakarta and West Jakarta attended by heads of districts, representatives of citizen groups, women's associations and individual members of the community. Slides were presented and discussions took place covering environmental issues such as garbage disposal, high rates of disease and lack of recycling programmes.

On 19 September, the clean-ups began involving 500,000 people. Target areas were residential districts, main roads, squatter settlements and areas with poor drainage

facilities. Soka trees, supplied by the local government, were also planted. At least 3,500 garbage bags were filled and picked up by garbage trucks circulating the sites. The Mayor of West Jakarta supported the event, as did the media. Television stations aired locally-made community service announcements throughout Indonesia and the national Radio Republik Indonesia reported on the event.

The event coordinator, Trisakti University in Jakarta, is compiling an evaluation report for the Minister of Demography and Environment. This report will include a proposal for a national Clean Up event in 1994.

The Republic of Korea

Clean Up Korea, held over the weekend of 17-19 September, 1993, was the largest environmental event in Korean modern history. A staggering 9 million people from about 4,300 groups (including boy/girl scouts, the Red Cross, YMCA and YWCA) took part. They collected 14,000 tons of rubbish.

Clean Up Korea was organized by the *Chosun Ilbo* ("The Chosun Daily"), the oldest newspaper in Korea, with a national circulation of over 2 million. The *Chosun Ilbo* has championed many environmental campaigns and issues over the last few years with great success. Clean Up the World was very actively promoted by the newspaper in the lead-up to the event, often on the paper's front page.

Clean ups took place in every corner of the country - on beaches and mountains, and in harbours, urban areas and neighbourhoods.

400,000 members of the Korean army and navy joined the event, cleaning up over 1300 sites with diver boats, vehicles and helicopters.

IBM gave much assistance to Clean Up Korea including the production of the "How To Do It" guide book in Korean. The Munhwa Broadcasting Corporation televised the event live for seven hours and mobilised 200 staff members to cover 10 provincial networks. Well-known TV stars joined the TV coverage and delivered messages on environmental themes.

Mr Kim Myung-kyu of the *Chosun Ilbo* said, "Now we are collecting the 'rubbish reports' from every participant, with which we will analyse the collected waste." He added, "We believe that every participant was convinced that an individual can make and made a difference by joining the event. The *Chosun Ilbo* is thinking of making it an annual event."

Malta

The third annual clean-up event in Malta was held from 17 to 25 September, 1993 as part of the Clean Up the World campaign. The event - comprising activities at 160 locations and involving 4000 participants - was organized by the Environment Secretariat (part of the Maltese national government), based in Floriana.

Xummiemu, the Environment Secretariat's well-known mascot that promotes environmental awareness (see p.12), played a key role in promoting Clean Up the World. A Xummiemu cartoon was broadcast several times daily on

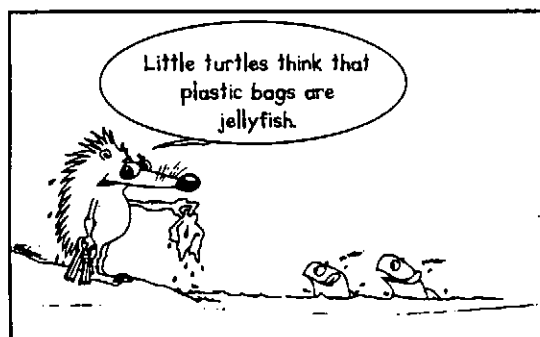

local television, and the cleanliness-loving hedgehog visited clean-up sites throughout the week's activities. A Xummiemu skipmobile

specially-designed for the campaign was an instant success, especially with the children.

Clean-up campaigns were organized in urban centres, rural areas and underwater. First aid kits were distributed to all participating groups, together with gloves, bags and tools. Groups were asked to complete a special form to quantify and analyse the amount of rubbish collected. Early reports indicate that apart from discarded rubbish, paper, packaging and white goods, thousands of bottles, used tyres and iron scrap were retrieved. Other aspects of the campaign included:

- * 50,000 paper litter bags were distributed to motorists from petrol stations throughout the country to minimise the roadside dumping of common items such as cigarette packets, wrappers and tissues.
- * A large number of flower pots were distributed to families to put on their window sills with the hope that flowers would enhance neighbourhoods.
- * A local organization, the Kerygma Movement used the opportunity of the Clean Up the World campaign to conduct a survey among thousands of Maltese to determine the island's major environmental problems. Results will be released in the near future.

Mexico

(I) Mexico City

Nucleo Radio Mil (NRM) is a network of seven radio stations in Mexico City. With the assistance of the Australian Embassy, the network coordinated Clean Up the World in that city. The aim of NRM's campaign was to heighten local awareness of the garbage problems facing a rapidly-growing city such as Mexico City. From early August, the stations broadcast environmental messages, and a variety of news programmes looked at the issues in detail. There were interviews with local environmentalists and the Australian Ambassador, Mr Keith Baker, who played an active role throughout the whole campaign.

The Australian Embassy produced the *How To Do It* brochure in Spanish, and distributed it to Australia's other Spanish-speaking posts and environmental groups throughout Mexico.

Among other activities, the Embassy worked with a public school in one of the poorer areas of the city on a clean-up in which 1800 students and parents took part.

City Hall sponsored a number of activities, such as a beautification scheme for local communities and the provision of trucks and cleaning equipment. Collected materials were recycled as much as possible, and the most common items found were plastic, sweet wrappers, junk-food packaging, paper, glass and tyres. Refrigerators, paint cans, stoves, tables and mattresses were also uncovered. A collection station that was set up for recyclables collected over 2 tonnes of newspaper and an indeterminate amount of glass.

The Organizing Committee produced brightly-coloured vests for volunteers to wear, and food and drink were provided to all those who took

part. Since the event, three different schools in Mexico City have contacted NRM to start newspaper recycling drives and clean-ups in their areas.

(II) Guanajuato

In the city of Guanajuato, 6000 people took part in a clean-up event which lasted for, in some locations, as long as ten days. Coordinated by Fundacion Mexicana Para La Cultura de Servicio AC, Guanajuato, the event aimed at cleaning up streams; roadsides and public places within the city, and encouraging

recycling. Another long term goal was to address chemical pollution in waterways.

An Ecology parade by social clubs and primary schoolchildren was held. Boy scouts, Lions Clubs, high school and technical school students, environmental groups and Bankers Club joined together to collect 166 tonnes of rubbish. The Department of Public Services, responsible for garbage collection in the city of Guanajuato, removed rubbish throughout the event, and will now be starting its own programme for garbage segregation.

Nepal

Clean-up events were organized by the Nepal-Australian Friendship Society in conjunction with the Embassy of Australia in Kathmandu, the Nepal-International Consumer Union, the Hotel Association, the tourist industry and several sponsors including Qantas. Clean-ups took place in the historic city centres of Kathmandu, Bhaktapur and Lalitpur in the Kathmandu Valley. At least 15,000 people took part in these major areas alone.

Rubbish problems are severe in rivers, ponds and lakes throughout Nepal, and there is inadequate garbage disposal facilities in urban areas. The local communities received information brochures and messages on television, radio and newspapers, on their role in environmental care. Many activities focussed on encouraging schools, children and boy scout and girl guide groups to take action, with tree-

planting exercises and a poetry symposium. The campaign proved to be very successful. It involved government ministers, municipality staff, students, boy scouts, girl guides, NGOs, business and community groups and a large number of the general public. Huge amounts of rubbish were collected. In just one area - Bouddhanath Stupa, a major tourist site and buddhist temple complex - fifty-eight trucks of garbage were taken away. Since the event, a local youth group has set up a 24-hour guarding service at Bouddhanath Stupa to ensure the inhabitants dispose of their rubbish in the designated areas. There is also a campaign to install bins throughout Kathmandu. The Nepal-Australian Friendship Society is planning to visit schools over the next six months to continue the awareness programme that Clean Up the World has started.

The Philippines

The Philippines, an estimated 20 million people took part in clean-up events. In Cotabata City 23,000 school children focussed attention

on the collection of plastic waste which is to be recycled and re-marketed as part of their income-enhancement programme.

Taiwan

The Organizer in Taiwan, Mr Jay Fang from the Green Consumer Foundation, reported that 100,000 volunteers took to the streets across the country to remove rubbish from some 1500 sites including parks and residential areas. People were amazed at how much garbage was

collected in a short time, and families, including children, learned how to clean up their communities, and how to avoid dumping garbage in the future. The clean-up was so successful, the campaign was extended for the whole month.

Thailand

According to Khuning Chodychoy Sophonpanich of the Thai Environmental and Community Development Association, 500,000 people from all over the country took part in the

Clean Up the World campaign targeting 8,500 sites. One of the highlights was the clean-up of 22 temples on Rattanakosin Island which were cleaned up by 30,000 students.

Vanuatu

A six-man Organizing Committee formed from the Kiwanis Club of Port Vila took three and a half weeks to prepare for the Clean-up event in Port Vila. Meeting three times a week, the committee helped organize 75 site supervisors and 2,000 volunteers from 9 schools and 14 community groups. On the Clean Up day - 18 September, 1993 - children, teachers, youths, parents and local businesses collected 6,500 bags of rubbish, of which 1000 were recyclable bottle caps.

The event began with a parade through Port Vila in which the President of Vanuatu participated, and ended with a barbecue lunch for all volunteers provided by a local sponsor.

On the outer island of Vanua Lava, in the north of Vanuatu, the local village was cleaned up, as was the local river which was said to house evil spirits. As a result of the clean-up, it was reported by the village chief that the spirits have gone, and the children can play there once more.

FICTION

Happy Beach, Sad Beach

SOURCE

Reprinted from the Fall 1991 issue of *Earth Notes for Educators*, (Grades K-6), a publication of the U.S. Environmental Protection Agency, 401 M Street, S.W. (A-107), Washington, DC 20460, U.S.A. The story is adapted from an activity by Carmen E. Trisler, Great Oaks Joint Vocational School, Cincinnati, Ohio and the Ohio Sea Grant Education Program in Great Lakes in My World. If reproduced for non-profit, educational purposes in low-income countries, please credit source.

SUGGESTIONS FOR USE

Teacher, Youth workers: As an introduction to projects on waste.

Radio broadcasters: As part of a youth programme on the importance of litter prevention.

Children's environment and health magazine/newspaper supplement editors: As the basis of a story for an issue on the theme of waste and litter prevention.

This is a story for five and six-year olds that explains the consequences of littering water and shorelines. The tale describes how Happy Beach became Sad Beach until a group of children took action. In class, students can act out the parts as the teacher reads. Afterwards, the students can make touch-and-feel pictures of Happy Beach or Sad Beach. Each child can present his/her artwork to the class.

Once upon a time, there was a place called Happy Beach. It was a pretty beach with sparkling sand and a gentle surf which lapped on its shore. Schools of fish swam in the cool, clear water, and a family of ducks bobbed on the calm surface. Children came to spread their towels on the warm sand. All were glad to be on the Happy Beach.

Many people used Happy Beach in the summer. Some tried to catch fish with rods and reels. When they were finished, they threw their tangled lines on the sand or in the water. Some sat in the warm sun drinking pop to cool off. When they were finished, they threw their cans on the sand. Some enjoyed picnics by the water. When they were finished, they threw their plastic plates and forks on the sand.

Happy Beach soon became Sad Beach. The fish got their fins twisted in the old fishing line and died. The ducks got their heads caught in the six-pack rings from the pop cans and died. The children cut their feet on plastic forks

and cried. Trash was everywhere.

Finally, one small child had enough. She made her small voice as loud as she could and shouted, "STOP! Stop littering our beach! We need to teach people how to use the beach without leaving trash everywhere!"

Soon each child was telling a parent, a friend, and a teacher not to litter the beach with garbage. "STOP! Stop littering our beach!" they said.

People got the message. Some still tried to catch fish with rods and reels, but when they were finished they took their tangled lines home. Some still sat in the warm sun drinking pop to cool off, but when they were finished they threw their cans in the recycling bin. Some still enjoyed picnics by the water, but when they were finished they threw their plastic plates and forks in the garbage can.

After a while, Sad Beach became Happy Beach again and things went back to normal.

How Garbage is Collected and Managed in One Favela in North East Brazil

SOURCE

Adapted from "The Collection and Management of Household Garbage" by Stenio de Coura Cuentro and Dji Malla Gadji in *The Poor Die Young: Housing and Health in Third World Cities* edited by Jorge E. Hardoy, Sandy Cairncross and David Satterthwaite (published by Earthscan Publications Ltd. (1990), 120 Pentonville Road, London N1 9JN, United Kingdom). Earthscan Publications Ltd. is an editorially independent and wholly owned subsidiary of the International Institute for Environment and Development. If reproduced, please credit original source.

SUGGESTIONS FOR USE

Teachers: For study and discussion in class projects on finding solutions to waste problems in urban areas.

NGOs, Radio broadcasters, Journalists: To make audiences aware of some solutions to urban waste problems in low-income urban settlements.

Greater Recife in Northeast Brazil grew from 554,000 inhabitants in 1940 to over 2.3 million in 1980. It is made up of twelve municipalities, of which Olinda (330,000) is one of the most populous. In 1983, the municipality of Olinda selected a favela (low-income settlement), called Triangulo de Peixinhos for a pilot upgrading project.

Triangulo de Peixinhos is a settlement with 450 low-income families covering an area of 3.5 hectares. The origins of the favela date back to 1945. In 1983, only a handful of the occupants held legal titles to the land they occupied.

Triangulo de Peixinhos is built in a swampy area which had previously been used as a rubbish dump. Until the project in 1983, houses were often flooded in the rainy season, and the settlement's streets, which were not paved, became mud-paths because of no system to drain storm or surface water. The ground water from which many inhabitants obtained their drinking water was often contaminated with water carried by the floods from the local pit latrines and from the rubbish dump. When 272 of the 1,350 inhabitants were tested for intestinal parasites, all but nine tested positive. While the water supply was inadequate, most dwellings were connected to the electricity network.

There was no municipal garbage collection services. Only part of the household refuse was placed in a skip. The rest would usually be left to rot in the streets or would be dispersed by the wind and rain close to the inhabited areas.

Faced with such problems, the project team realized that anything it did needed to involve the local community. The team also realised they needed to provide simple but effective solutions to the lack of basic infrastructure. This

they tackled first. A drainage system was installed for the whole settlement. Then, latrines were built, individual houses were upgraded, and roads and access paths were paved.

Three major cleaning actions were organised in which the community took part. The first was a general spring cleaning of the whole settlement. With the help of the municipality, the garbage, which had accumulated in different parts of the favela, were collected while every household got rid of discarded objects and pieces of furniture. Altogether, some 50 tons of rubbish were collected.

A second, more regular and permanent initiative followed: the daily collection of refuse using a simple hand-pushed cart. Operated by one person, the cart has a capacity to carry up to 180 litres of rubbish. The light-weight steel structure with two bicycle wheels was designed and constructed by a local firm, with the support of the municipality of Olinda. The cart's design makes it ideal for this type of work as it combines a sturdy yet light body which is easy to maintain with a relatively large capacity. In addition, its small size allows it to reach houses only accessible through the narrowest of streets and alleys.

A composting plant was the third major cleaning action. The director of Olinda Waste Management, Engineer Rodolfo Aureliano, designed the small composting and recycling plant which was located in the same 25-hectare plot of land as the favela's skip.

The compost plant is relatively small with an operational capacity of one tonne per day. The technology used in building the plant was an extension of the simple techniques and

materials used in the upgrading of the favela. For instance, a soil-cement mixture was used for paving the site of the plant. After 18 months of hard work with the help of inhabitants, the plant began operations.

The small plant offered clear advantages over a centralised system of rubbish collection for the whole city. Firstly, unskilled labourers were given jobs during construction, and secondly, running costs are comparatively low, partly because the community is involved in the everyday running of the plant.

How the composting plant operates is described in the box below.

According to figures gathered in the plant in 1984/5, between 8.9 and 14.2 metric tonnes of garbage were processed every month. Of these between 62 percent and 73 percent were compostable, between 3.5 percent and 6.3 percent were recyclable, and between 22 percent and 34 percent were discarded. The volume of compost produced varied greatly from one month to the next but on average the volume produced was roughly equivalent to a quarter of the garbage processed.

By the end of 1985, the plant was still working below capacity. This is shown by the fact that the largest daily average amount of garbage handled in any given month was 595 kilograms (in June 1985). Perhaps, not surprisingly, the favela's households produced less refuse (an average of 0.28 kg. per person per day) than middle- or high- income households in other parts of the city (between 0.5 and 1.5 kg). This is an indication of the low levels of consumption found in the poorer area,

land also of the fact that certain objects, such as tin, glass jars and bottles and newspapers, are not discarded but either kept or sold by the households themselves. The proportion of refuse that can be recycled in higher-income areas is typically of the order of 8 percent, and may go up to 15 percent.

In the early 1980's when the Triangulo de Peixinhos composting plant was being built, Recife's metropolitan authorities were making plans for restructuring the solid waste management services of the metropolitan area. The plan proposed centralizing operations. It involved a number of trucks of different capacities collecting and transporting refuse to a large sanitary landfill outside the built area. The metropolitan authorities' plan was challenged by the smaller municipalities (particularly that of Olinda) where more environmentally and socially sensitive refuse disposal projects were being developed. Under such pressure, the centralisation plan was abandoned in favour of those schemes which involved greater local control.

Olinda's authorities produced plans for seven more composting plants similar to that of Peixinhos, but in most cases much larger. For example, the next one that was built has a capacity of 7 tonnes every day. These composting plants will process around 40 per cent of the garbage produced by the municipality. The systems of rubbish collection and cleaning of streets have been designed with the areas in mind. A combination of large compacting lorries, pushcarts and animal traction carts are used, the mix depending upon

How the composting plant in Triangulo de Peixinhos operates

The composting plant operates in a series of steps as follows:

1. All rubbish is collected in an open 2 metres x 3 metres x 0.5 metres tank at ground level.
2. The recyclable matter (glass, paper, plastic, etc.) is removed by hand and placed in different 50-litre metal barrels, classified according to type of material, colour, and texture. These materials are sold.
3. The compostable waste (organic material - mainly discarded foodstuffs) is weighed on a portable scale on wheels and then piled up in heaps some 1.2 - 1.6 metres high in the composting yard. These heaps are covered with finished organic compost to keep off flies and other insects.
4. The water content and the temperature of the heaps is checked regularly. The piles are turned over at intervals of three to seven days, and water is added as needed. The first stage in the composting process takes some 60 days. At the end of this first stage, the compost is a topsoil-like substance, odourless, with a brown or ash colour, and free from the pathogenic elements which can be harmful to humans.
5. The compost is then moved to a corner of the courtyard where it is left untouched for another two weeks. At the end of this period, the compost will be stable both physically and chemically.

local conditions. In all cases, experience in Olinda has shown that substituting existing complex and expensive technology with

cheaper, more low-key techniques has proven to be viable and closer to the needs and realities of the people it is designed to serve.

Turning Garbage into Gardens in Porto Novo, Benin

SOURCE

Adapted from "Garbage into Gardens" by Ruth Massey in *Development Forum* Vol.19 No.4 (July-August, 1991). *Development Forum* is published by the United Nations Department of Public Information for the Joint United Nations Information Committee. If reproduced, please credit original source.

SUGGESTIONS FOR USE

NGOs, Community workers: As one type of youth-employment scheme to consider for the local community.

Radio broadcasters, Journalists: To make audiences aware of how one group has tackled waste disposal in its community. This information may inspire people to take local action.

Porto Novo, the capital of Benin, has a population of around 150,000 and a run-down, ramshackled look to it. Its narrow streets are lined with once-grand houses that are now crumbling. Enormous piles of rubbish lie rotting in the streets.

There used to be even more rubbish in this West African city. It was never collected. Some heaps grew as high as a four-storey building. This caused health problems, and drove people out of neighbourhoods where the stench was unbearable.

Then, a rural development expert, Veronique Gnanih, made a suggestion:

"Why not create a composting centre in order to transform the garbage into fertiliser? This would help enrich the poor soils of the Porto Novo region, and create jobs."

Veronique took action. She obtained funding for the project from the Centre Panafricain de Prospective Sociale (CPPS). In the village of Tohoue, she found a site of several hectares on which to recycle the rubbish, and CPPS bought the land to launch the project on an experimental basis. A French non-governmental organisation, Emmaus International, provided the project with a tractor and two trailers.

"We parked the trailer in two locations--one near the station and the other near the football stadium--and people started dumping their rubbish in them," Gnanih explained. "It was as if they knew instinctively what the trailers were there for."

Every evening the tractor tows the trailers back to the recycling centre in Tohoue. There,

21 once-jobless youths sort out the rubbish.

First they remove plastic, metal, glass and all other substances that do not decompose biologically. They sell the metal to the blacksmith. The glass is crafted into jewellery by local artisans. The plastic is kept aside because they still have not found a use for it.

The organic refuse is thrown into pits and covered with palm fronds, which help to turn the garbage into compost. Humidity, air flow and heat are checked regularly to make sure that fermentation takes place correctly. After two months the fresh compost is ready for use.

A laboratory at Toulouse University tested some compost samples and discovered it did not contain enough nitrogen to allow adequate fermentation. The laboratory suggested water hyacinths should be added to the compost.

As it turned out, water hyacinths with a high nitrogen content were found growing in abundance in a lagoon outside Porto Novo. In fact, the plants were depriving fish of oxygen, and this was worrying local fishermen.

"Now, when we take hyacinths for our compost," says Gnanih, "we're also doing the fishermen a favour."

On the recommendation of Toulouse University, the recycling centre built a latrine with a small wastewater purification tank. This tank doubles up as nursery for fish. The latrine empties out into a long, shallow tank lined with blue plastic.

Every so often, the centre staff add water hyacinths, which grow rapidly in the nitrogen-rich water. Besides being used for compost, the plants, which are rich in vitamin A, make

nourishing fodder for pigs and chickens. Chickens, fed on the plants, produce eggs with harder shells and more yellow yolks.

The tank is kept relatively free of flies because of frogs, that live in the web of water hyacinth leaves and feed upon flies and mosquitoes that are attracted to the pond. Tilapia and catfish thrive on the pond's fecal matter, acting as a purification agents and helping render the tank free of odours.

The youths employed in the recycling scheme have branched out into market gardening. With funds from the United Nations Development Programme's Partners in Development, the centre bought seeds and more land for growing crops.

In this region of Benin, the sandy soil, never rich, has become poorer still due to over-use. Says Kodjo Gato, a youth that works at the centre, "My father and friends told me it was useless to try and grow anything on this land." Yet in one year the 18-year old proved them wrong. The soils of Tohoue produced lots of tasty vegetables.

"They couldn't believe their eyes when they saw our spinach," says Gato. "Using five wheelbarrows of compost, we got three crops from a plot of 120 square metres."

This is good news to a region where malnutrition and poverty are endemic.

The villagers are now paying for compost to

use on their own gardens. Gnanih says, "They were amazed at the amount of corn and manioc they could produce on what they thought was infertile soil."

In addition to the spinach, the youths grow cucumbers, green beans, cabbage, peppers and onions. Because meat is expensive in Tohoue, the project organisers are also cultivating vegetables rich in protein, such as "ablat", a bean that requires very little water to grow.

"We just put a bit of compost around the foot of the plant, and it produces beans all year round," says Gato. He has learned to make seed beds and keep records of planting, harvests and sales.

Many who buy the produce say it is of higher quality than vegetables found in the local market. It also keeps longer.

"We were able to keep cucumbers for one month without refrigeration," says Gato, adding that cucumbers usually start to rot after a week. "Now we are experimenting with cabbage to see if it too will keep longer."

As with other young men selected to work at the centre, Gato says he has learned enough about market gardening to be able to train others. Money earned by the centre from selling vegetables and fertiliser is put towards buying more equipment and hiring more unemployed youths to work as garbage sorters and trainee market gardeners.

ARTICLE

Turning Garbage Disposal into Jobs for Women

SOURCE

Taken from *The Tribune* newsletter 49: Women, Environment and Development part II (February 1993). *The Tribune* is a Women and Development Quarterly newsletter published by the International Women's Tribune Centre, 777 United Nations Plaza, New York, NY 10017, USA. If reproduced, please credit the International Women's Tribune Centre and artist, Laurel E. Douglas, and send copies of reproduced material to the IWTC.

SUGGESTIONS FOR USE

Community workers: In "how-to-do it" meetings as encouragement for people planning community waste disposal and sanitation schemes or income-generation projects for women.

Radio broadcasters, Journalists: In reports on income-generation schemes for women or on waste disposal projects.

BOTH SITUATIONS ARE SERIOUS. ON THE ONE HAND, Malian women graduates find it very hard to find employment after they finish university. On the other hand, the population of Mali is rapidly expanding, and waste disposal and the lack of sanitation are serious problems, particularly in cities such as Bamako.

To try and find solutions to these problems,, the *Union Nationale des Femmes du Mali* (National Union of Women of Mali) met together and discussed possibilities. They approached PROWESS (Promotion of the Role of Women



in Water and Environmental Sanitation), a project of UNDP, and together launched a project in Bamako that addresses both problems.

Sixteen young female graduates were selected and trained in small enterprise management. A garbage collection cooperative was formed, and a fund created for enterprise revenues that could be used to create their own small businesses. Training materials were developed in the areas of sanitation and family health, and a participatory survey undertaken in the area where the 16 graduates would be working.

Through the help of the project, 16 graduate women have now started their own businesses in waste disposal. The environmental and health situation is improving in the Medina-Coure neighbourhood, which has about 17,500 inhabitants. And there is more awareness on health, sanitation and family planning issues among poor women and their families. Both the local government and other municipalities have responded enthusiastically to the initiative and are considering similar follow-up efforts.

From: Global Assembly of Women and the Environment, 1991



ARTICLE

Thai Schoolchildren Tackle Waste

SOURCE

The following articles are reprinted from: *Thailand's Children and the Environment*, a publication of the Royal Thai Government under the coordination of the Environmental Awareness Committee and the Office of the National Environment Board with support from UNICEF. If reproduce, please credit original source.

SUGGESTIONS FOR USE

Teachers: Adapt the ideas for use with students: (1) Have students design local litter campaign, and put ideas into action; (2) Identify local waste problems that students may have creative ways of resolving.

Children's environment and health magazine/newspaper supplement editors: Use the ideas as a basis of comic strips, stories or local competitions.

The Disappearing Krathongs

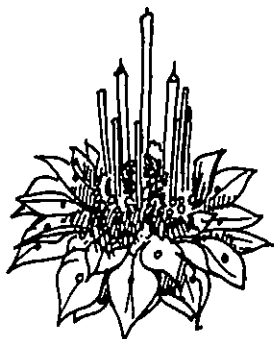

Each full moon November night, waterways are lit by "krathongs".

Each November, as the full moon is rising, the rivers of Thailand begin to shimmer with pinpricks of candle-light as millions of Thais of all ages float tiny boats called "krathongs" to celebrate Loy Krathong. Laden with candles, incense, flowers, and small coins, the "krathongs" are offerings of thanks to the river for its bounty and a request for blessings during the coming year, especially for young lovers.

The rising sun the following morning reveals riverbanks clogged with millions of these boats. Their styrofoam hulls will continue to pollute the waterways for months until they have finally floated away to the ocean, there to create another pollution problem.

But all this is changing. After a trial run in 1990, celebrants in 1991 were asked to return to the traditional "krathong" hull made of natural materials. The goal was to reduce styrofoam pollution by 30 per cent.

Work began in March and

schoolchildren were enrolled as the task force. Art classes were devoted to making "krathongs" from cheap materials. School competitions in Bangkok and the northern city of Chiang Mai selected the best "krathongs" made of banana stalk slices, leaves, water hyacinth, coconut fibers, reeds and other biodegradable materials.

The results surprised even the optimists. Only three per cent of the "krathongs" floated in the city had styrofoam bases. This year, the programme includes upcountry schools and is being tied to another programme to encourage the propagation of banana trees.

Because banana trees take six months to mature, the campaign was launched in March and is receiving enthusiastic response. Adult makers of "krathongs" report that in 1991, sales of styrofoam-based "krathongs" were so low that this year, they, too, will be switching to natural materials.

Magic Eyes

"Ah-Ah! Don't litter! Magic Eyes Sees You."

These teasing words, inscribed under a pair of stern eyes that gently scowl from bus sides, litter bins, schoolbags, and T-shirts, have become the most effective anti-littering message in Thailand's history. They originated with a children-based campaign to shame adults into cleaning up trash.

Founded in 1984 by a prominent businesswoman, Magic Eyes directed its initial efforts at society at large. The response was "Everyone litters. You can't change people's ways." Magic Eyes realized that it was best to appeal to children whose habits can be changed, and to influence them to police adults. The "Ah, Ah, Magic Eyes Sees You" slogan lets a child point a finger at adults without seeming rude.

From anti-littering, Magic Eyes expanded its activities to include water pollution and tree-planting, and helping the child to see the environment as an integrated whole.

Among its activities are annual "Clean School" contests, painting contests, puppet shows, stage dramas, and slogan and essay contests. The "One Minute with Magic Eyes" educational series, aired daily on television, focuses on three topics:

water, forests, and litter. Three 30-minute Magic Eyes video programmes on these subjects have been created for schools and institutions.

In one campaign, primary school students are asked to formulate an environment-related project. They create basic guidelines and a work plan which they carry out over a nine-month period. Their final report is submitted to the Magic Eyes judges for consideration. Projects can include tree plantings and clean-ups of Buddhist monasteries. Prizes are awarded for the best projects. Since 1985, this programme has been conducted in 900 schools.

Magic Eyes is best-known for its "Love the Chao Phya" campaign. In 1990, 80 children were taken by boat down Bangkok's polluted main river where they saw floating rubbish. Two water quality experts explained how the Chao Phya was being contaminated, and advised the children on what they could do to help clean it.

On the return trip, children painted pictures depicting the ideal Chao Phya. The campaign was so successful that it attracted the attention of riverside restaurant and factory owners who have begun cleaning up their effluents and involving themselves in community action to restore the river to life.



The logo of the campaign, a disembodied pair of black and white eyes set in a bright green circle, lent the project its name, "Magic Eyes". In Thai culture, Chodchoy Sophonpanich, the campaign's founder, explained, "everyone is afraid of ghosts -- and the eyes remind them of ghosts."

Wealth from Wreaths

A group of Thai secondary school students has transformed an environmental problem into a profit-making venture that offers lessons in dealing with pollutants.

For decades, funeral wreaths have been backed with styrofoam. With growing concern over the accumulation of styrofoam in landfills, teachers began exploring alternatives, drawing on Thailand's rich craft tradition. Working with students, they created backings woven from water hyacinth, grape vines, and straw. They found them sturdy, environmentally friendly, and, best of all, reusable.

As part of their secondary school activities, students must form and operate a small company to give them business experience. It was a small step from turning an art class into a business enterprise.

At Pothinimit Witthayakhon School, Pakkret, Nonthaburi, north of Bangkok, students formed a limited partnership with nine students and two faculty advisors. Each member bought 10 shares at 10 baht each and the money was used to purchase raw materials. In producing their wreaths, the students combined environment considerations with social concern. They fashioned bed

and bath towels into wreaths, sewing small towels into flowers and crabs. After the funeral, the threads are removed and the towels are donated to poor families.

Working at lunch times and after school, the students produced dozens of funeral wreaths which they sold in the neighborhood for 350 baht (US\$ 14) each. Within a month, they had earned several thousand baht profit.

Today, Pothinimit Witthayakhon students' success is being repeated in other schools and there are predictions that in the near future styrofoam backings will have disappeared from the floral wreath market.

Fun and games with a serious purpose

by Zadie Neufville

SOURCE

Reprinted from *Panoscope* No. 34 (January 1993). *Panoscope*, an Environment and Development magazine, is produced six times a year by Panos, an independent institute working to promote sustainable development. This *Panoscope* material can be republished free of charge in developing countries with attribution to Panos. For further information, contact the Panos Institute, 9 White Lion Street, London N1 9PD, United Kingdom.

SUGGESTIONS FOR USE

Teachers, Youth workers, Students: As inspiration for initiating extra-curricular environmental activities.

Radio broadcasters, children's environment and health magazine/newspaper supplement editors: As ideas to spread to audiences/readers and thereby encourage similar local initiatives.

Environmental education in Jamaica is strictly practical: children learn as they do, and teach as they learn.

Children at a primary school in Kingston have taken it on themselves to do something useful with the waste that clutters up the schoolyards between too-infrequent garbage collections. The Art Recycling Club, a group aged 7-9, turn old cartons, straws and plastic bags into cards, decorations and toy cars. Children in other schools have followed their example.

In one rural area, students run their own environmental groups, Portland Environmental Protector (PEP) clubs, under supervision from teachers. Children in the clubs, aged 6-18, have pledged to protect the earth. Older children make up songs and games about the environment, often using popular folk or work song tunes, to teach the younger children. Environmental quizzes are one popular game (see box).

The clubs have set up tree-planting and recycling projects, and some have built compost bins, designed solar ovens, and even made miniature gardens enclosed in glass to demonstrate how water is cycled through plants, air and soil.

The children are now not only learning from and teaching themselves and each other, but are also finding ways to spread their environmental message. Other clubs are starting up outside the area, borrowing songs and games from the original groups, and sending back their own. Soon the message will be available all over the country in the shape of an environmental board game produced by the PEP clubs. The game features a map of Jamaica, and you progress around the board winning or losing points depending on whether your actions help or harm the environment. The game is being sponsored by the UN Development Programme and the World Wide Fund for Nature.

The government is sufficiently impressed with the PEP clubs that it may set up a nationwide network. The idea of people teaching each other about the environment is already accepted in

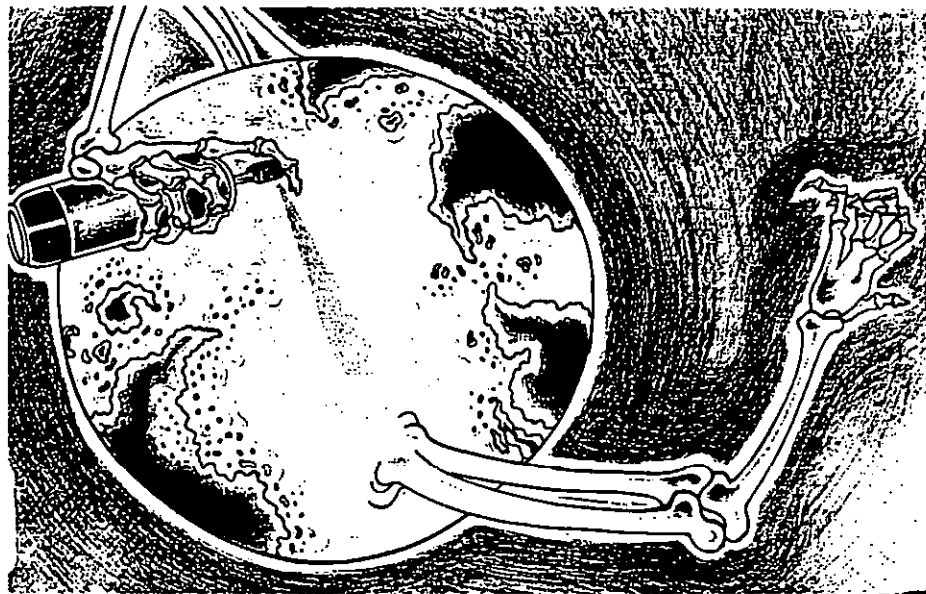

Jamaica: it is the basis of a programme at the Blue Mountain/John Crow Mountain national park, where community members spread the conservation message to their neighbours. But children may be the most efficient communicators — and doers — of all. ♦

Cuban cartoonist Carlucho draws attention to global environmental problems: ozone-destroyers continue their deadly activity

Typical quiz questions:

1. What is a watershed?
2. What is its function?
3. Name some reasons trees are important.
4. What is the smallest Jamaican bird?
5. Name two endangered Jamaican animals.

Answers:
 1. A watershed is the drainage basin from which water systems are fed.
 2. A watershed is a reservoir for water which flows into rivers and amount of water which flows into rivers.
 3. Trees protect the watershed, provide oxygen, prevent erosion, and regulate the water supply.
 4. The veeryn hummingbird.
 5. Any two of the following will do: crocodile, iguana, coney (a relative of the Guinea pig), Jamaican yellow snake, sea cow.

Issue 92

Waste part 2: Conserving Natural Resources

CONTENTS

	Page(s)
Location map	ii
How to use this pack	iii
Wasting our natural resources	Questions & answers 1-6
Learning for nature - want not, waste not	Comic strip 6-7
How does waste affect our natural resources?	Class/group activity 7-8
Reduction at source: some facts and opinions	Class/group activity 9-10
How paper and plastic bags are made	Article 11-13
Packaging	Class/group activity 13
About aluminium	Statistics 14-15
Not everything made from scratch is best	Class activity 15-16
The life cycle of a discarded product	Class/group activity 16-17
Don't throw away -- reuse	Class/group activity 17-18
Tin can football	Activity 18
Composting waste	Activity 18-20
Worm composting	
(or save your back and let the worms do it)	Article 20-22
How to make a worm composting bin	Activity 22-25
Worm composting	Resources & activities 25-27
Make compost in small pits in the garden	Radio transcript 28-31
A burning issue	Class activity 32
Compare what happens to waste in a dump and and in a landfill	Class activity 33
Waste away crossword puzzle	Puzzle 34

LOCATION MAP

The map below shows the location of countries mentioned in OUTREACH issue no. 92:

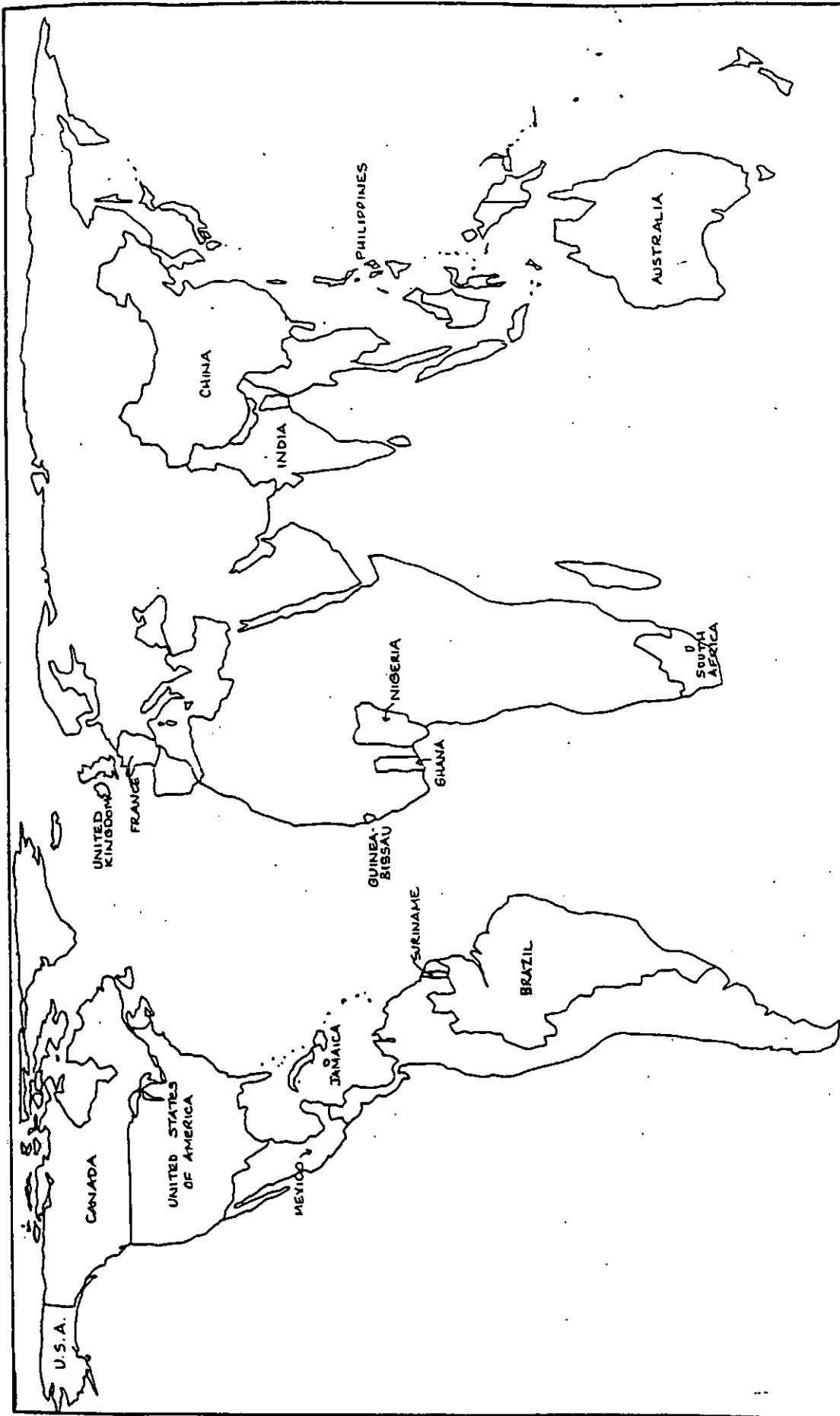

USEFUL CONVERSIONS FACTORS

linear measurements: 1 in. = 2.54 cm. 1 yd. (36 ins) = 0.91 m.

square measurements: 1 acre = 0.42 Ha. (1 km.² = 100 Ha.)

weights: 1 long ton (2,240 lb) = 1.02 metric tonnes

1 mile (1 760 yd) = 1.61 km.

1 sq. mile (640 acres) = 259 Ha.

1 short ton (2,000 lb) = 0.91 metric tonnes (1 metric tonne = 1,000 kg.)

How to use this OUTREACH pack

Issue 92: Waste part 2 - conserving natural resources

This pack is the second in a series of five OUTREACH packs that explore waste and recycling. It looks at ways people waste natural resources in the production, use and discarding of manufactured products, and then it explores how these resources can be conserved. The pack introduces the hierarchy of waste management practices that should be adopted in order to safely and effectively handle municipal solid waste with the least harmful impacts on health and the environment. In order of priority, these practices are:

- * **Reduction at source** (avoiding the creation of waste in the first place)
- * **Reuse of products directly**(use of goods and packaging more than once)
- * **Recycling** (convert waste into re-usable materials such as composting)
- * **Incineration** (with recovery of energy)
- * **Landfilling**

The first three priorities are often known as the three 'R's. While the pack introduces different methods of dealing with solid waste, particular attention is given to composting as this is a practice that can be adopted by individuals the world over. (It should be pointed out that the pack does not look at issues related to human solid waste: some of these issues have been explored in pack nos. 12-14 on water and sanitation and in pack no. 76 on Appropriate Water Technologies.)

Other packs in the waste and recycling series include three more general packs and one Learning-By-Doing leaflet pack:

- 91: Global problems, local solutions;
- 93: Recycling;
- 94: What to do with hazardous waste;
- 95: Learning-By-Doing leaflets on waste and recycling

At the beginning of each segment there are suggestions as to how the material might be used by multipliers. Here are some general suggestions:

- * **Community workers** might be inspired by the articles and resources on composting (pages 18-31), and on worm composting in particular (pages 20-27) to promote the various techniques in their local community.
- * **Print and radio journalists** might develop a series of articles or programmes, with each segment devoted to one of the waste management techniques mentioned in the question and answer segment on pages 1-6. A panel of local community leaders and waste experts could be invited to talk about the waste management techniques that are used in - or are being considered for - the local community. The series could conclude with a programme that describes what individuals can do to conserve natural resources.
- * **Journalists**, preparing special children's newspaper supplements on ways to conserve natural resources might find the pack full of useful background information.
- * **Teachers** can draw upon various activities in this pack to help students understand the value of the three 'R's, and to encourage them to act accordingly.

Wasting Our Natural Resources

SOURCES

Waste Away: Information and Activities for Investigating Trash Problems and Solutions for upper elementary and junior high students produced and published by Vermont Institute of Natural Science, Woodstock, VT 05091, USA; *Waste*, 3.83 in a poster series produced by World Wide Fund for Nature - UK, Weyside Park, Godalming, Surrey, GU7 1XR, United Kingdom; *Worldwatch Paper 101: Discarding the Throwaway Society* by John E. Young (Worldwatch Institute 1776 Massachusetts Avenue, N.W., Washington, D.C. 20036 USA, January 1991); *Let's Reduce and Recycle: Curriculum for Solid Waste Awareness - lesson plans for Grades K-6 and 7-12* produced by the U.S. Environmental Protection Agency, (1980, revised 1990), 401 M Street, S.W. Washington, D.C. 20460, USA. If reproduced, please acknowledge original sources.

SUGGESTIONS FOR USE

Teachers: As an introduction to discussions and projects on waste of natural resources, and local methods of waste disposal.

Children's environment and health magazine/newspaper supplement editors: As background material for an issue on the same theme.

Radio broadcasters: As a basis for a radio script on use of natural resources, and as an introduction to a programme exploring local waste management needs and opportunities.

Q. What is waste?

A. When something is unwanted or no longer serves a purpose, it is generally thought of as waste. Solid waste is any unwanted material, solid or semi-solid, that is "thrown away" by individuals, industries or communities. What is thought of as waste varies from person to person. One person's waste rags may be another person's recyclable clothes. What is thought of as waste may vary over time. The once waste products of the pulp and paper industry are now a source of fuel and chemical feed for animals.

Q. Do we all create waste?

A. Every living thing uses energy to process raw materials and creates waste. Nature's wastes - old leaves, animal droppings, shed skins - seem to disappear. But nature recycles its nutrients. Earthworms, millipedes and other soil creatures obtain food by digesting dead plants and animals. Microorganisms - bacteria, fungi and other decomposers - continue the process by breaking down the complex structures of dead plants and animals into simple components, such as carbon, nitrogen, phosphorus and potassium, which enrich the soil. Absorbed by plants, these nutrients are essential to growth, see Learning from Nature: Want not Waste Not on page 6.

Q. Can't waste generated by people be recycled in the same natural way?

A. Some of it can, certainly. Organic materials, such as vegetable peelings, fruit scraps, egg shells, ashes, sawdust, can be composted. Microorganisms feed on the materials and churn out a dark, rich crumbling substance called humus. When added to the soil, this humus is a natural fertiliser and also increases water retention in soil.

Q. So why is our waste a problem?

A. It is true that much of the waste we generate is organic, or biodegradable, and so is able to decompose, with the help of microorganisms such as fungi and bacteria. But people accumulate waste far more rapidly than it can be decomposed. The overloading of nature's "waste decomposing machinery" inevitably leads to water, air and soil pollution.

In addition, there are manufactured products that are not biodegradable. Some of these degrade through chemical breakdown - nails, for example, rust - but other products are neither biodegradable nor chemically-degradable. Neither time nor nature's elements will ever make this garbage disappear in the near future. Some synthetic materials, such as plastics, take so long to decompose (due to their molecular structure) that they are considered nonbiodegradable.

Q. Is the garbage problem getting worse?

A. Yes. The problem of waste grows with each new person on the planet. More people make

more waste. And as cities mushroom, the waste builds up.

But it's not that simple. As people earn more, they consume more, and they become more wasteful of the earth's resources. Too often, items are discarded when they could have been repaired or saved for other uses. Products are often designed for a relatively short life, to be cast aside for something new and more popular. Convenience goods are packaged in containers that are thrown away instead of reused.

Technology can also contribute to today's waste crisis. Before modern technology, the chore of harvesting the earth's natural resources, like minerals and petroleum, was extremely difficult. Today, with complex machinery, resources are taken relatively easily. This often leads people to think that it is an easy task to simply find and harvest more resources. Sometimes - through ignorance but often through a desire to make a quick profit - forests are cleared, minerals are mined and energy sources are used up with little thought given to what will happen when ores, energy sources and soils are exhausted.

Q. What can we do about waste?

A. Our disposal options are steadily being reduced. Open dumps, often the only waste disposal method available, have their share of problems, and in some countries are being phased out.

Q. What are open dumps, and what's wrong with them?

A. An open dump is an uncovered piece of land used for depositing municipal solid waste. The garbage is neither compacted nor covered, and so a dump smells terrible, and it becomes a breeding ground for flies and rats. Domestic animals feeding at a dump, and people scavenging from dumps, can catch diseases and spread them. When it rains, water running off a dump can carry pieces of garbage plus harmful chemicals and germs, and can contaminate land and water nearby. Landfills are considered a better alternative to the unsafe and unsightly open dumps.

Q. How is a landfill different from an open dump?

A. A landfill is often confused with a dump. In both operations, rubbish is brought to a location and deposited. But that is where the similarity ends. A landfill is a hole in the ground into which rubbish is tipped. Large earth-moving equipment runs over the garbage and packs it down. At the end of each day, all this compacted garbage is covered with a layer of soil. Each day's garbage becomes a buried 'cell'. The cell is surrounded by dirt on all sides. When the landfill is full, a thicker layer of dirt is put over the entire area, and the site can be developed. Since garbage is always covered at a landfill, few flies and rats can breed.

Q. Do landfills present any problems?

A. Yes, Several problems with landfills have been discovered. For example, many landfills--especially those that have been built on wetlands, gravel pits and other areas with porous soils--experience problems with leaching. Water seeping through the landfill mixes with buried waste such as battery acids, pesticides and other hazardous materials. This liquid waste, called leachate, can leak through soils and into surface water and groundwater. Fears about leachate contaminating water supplies have led several countries to limit landfilling to sanitary landfill sites.

Q. What are sanitary landfills and how can these help solve the leachate problem?

A. Sanitary landfill sites are lined with impermeable materials such as clay or plastic or built over impermeable soil to contain leachate. Lined landfills are very costly to construct. Some people claim that even liners and leachate collection systems are not permanent solutions to the leachate problem since tests have shown that plastic liners develop leaks when exposed to chemicals including solvents and acids.

Q. Do landfills present any other problems?

A. Yes. The rate of decomposition is extremely variable. It can be very slow due to compaction

and limited oxygen supply. Garbologists - people who study garbage - are discovering that many of the biodegradable materials that we have assumed would decompose in a landfill--do not. They have uncovered 50-year-old carrots, newspapers and other "biodegradable" items that are still intact. Methane build-up is another danger.

Q. What is methane?

A. Methane is a gas. It is produced during anaerobic decomposition, which occurs when little or no oxygen is present. This gas burns quickly and, if uncontrolled, can be dangerous. Methane contributes to the greenhouse effect, (see OUTREACH issue nos. 56 and 57). In some landfills, methane gas is being tapped and sold as fuel.

Q. So landfills are not the answer to waste disposal management?

A. Not really. Some experts believe that many of the problems of landfills can be avoided or controlled with proper siting, design and operation of disposal facilities. But this could be costly. Also, many landfills are filling up, and in many areas safe sites for new landfills are getting tougher to find.

Q. Is there no single, simple solution to a community's solid waste problem?

A. It is very unlikely. To effectively reduce solid waste management problems, communities need to consider a hierarchy of integrated management techniques.

Q. What does "Integrated management techniques" mean?

A. It refers to the complementary use of a variety of waste management practices to safely and effectively handle municipal solid waste with the least harmful impacts on health and the environment. The hierarchy consists of the following, listed in order of priority:

- * Reduction at source (avoiding the creation of waste in the first place))
- * Reuse of products directly (use goods and packaging more than once)) **the three 'R's'**
- * Recycling (convert waste into re-usable materials such as compost))
- * Incineration (with recovery of energy)
- * Landfilling

The United Nations Environment Programme endorses this hierarchy.

Q. Have countries adopted this hierarchy?

A. In theory, governments advocate reduction, then reuse and recycling with landfills as a last resort, but what happens in practice is often the reverse. Most governments focus on managing rather than reducing waste. They tend to fund waste management options in inverse proportion to their position on the hierarchy, usually moving one notch up the ladder when faced with a disposal crises. For example, the increasing concern about the health and environmental problems associated with landfills has led to more incinerators being built.

Q. What is reduction at source?

A. Actually, source reduction isn't about managing waste at all. It's about managing *natural resources* more carefully in the first place so that the amount and the toxicity of the waste we generate is reduced, see box 1.

Q. What kind of actions can we take to reduce waste?

A. Manufacturers may contribute to source reduction by designing and making products that contain fewer toxics and less packaging. As consumers, we can buy more durable and nondisposable goods; products that can have more than one "life", and products with less packaging and fewer toxic components. We can try to buy food in bulk, and store it glass jars. One of the best ways to lessen our waste disposal problems is to reuse many of the things we have habitually thrown out.

Box 1: Treating the symptom not the disease

The waste disposal crisis is but a symptom of a much larger problem: a global economy built upon the inefficient use of raw materials and energy.

Today's industrial economies were founded on the use of vast quantities of materials and energy. The economic health of nations has often been equated with the amount they consumed. But prosperity need not be linked so closely to consumption. A kilogram of steel may be used in a building that lasts hundreds of years or in several cans that may end up in a dump after one use. A few hundred grams of glass may be fashioned into a bottle reused 50 times or one immediately discarded.

The amount of materials that originally enters the economy tells us nothing about the material's eventual fate or its contribution to human well-being. But it does tell

us a good deal about the damage that economy has inflicted upon the environment.

Mines, like forests, oil fields and other sources of raw materials, are largely out of sight and out of mind for those who eventually use their products. But each year, raw material extraction -- mining, logging and the like -- damages or destroys millions of acres of land and forests and produces billions of tons of solid waste. It also pollutes air and water to a degree exceeded only by the world's production and use of energy -- much of which is generated to extract and process materials, anyway.

The waste generated by industrial economies that use up these raw materials is more familiar. This rubbish presents a massive disposal problem which continues to grow (often faster than population). Though the symptom

gets attention, politicians rarely diagnose the disease: a global economy built on the inefficient use of raw materials and energy.

As a result, the usual prescription -- increasingly more sophisticated technology for destroying waste -- allows the illness to progress unchecked.

By attacking the problem at its source, societies can move beyond treating the symptoms of their rampant consumption. Preventing waste through more efficient use of resources can both cut the garbage problem down to size and reduce environmental damage from producing raw materials.

Source: Adapted from text in *Worldwatch Paper 101: Discarding the Throwaway Society* written by John E. Young (January 1991), published by Worldwatch Institute, 1776 Massachusetts Avenue, N.W., Washington, D.C. 20036, USA. If reproduced, please give acknowledgment to the Worldwatch Institute.

Q. What is recycling?

A. Recycling involves collecting discarded materials (such as glass, paper, metal and organic waste), processing these materials and making them into new products.

Q. What are the benefits of recycling?

A. There are six main benefits. Recycling:

1. reduces the amount of solid waste requiring disposal;
2. saves natural resources, including nonrenewable resources such as petroleum.
3. reduces the amount of energy needed to manufacture new products;
4. reduces pollution and destruction caused while obtaining new raw materials;
5. provides employment opportunities; and
6. helps the national economy when fewer raw materials have to be imported.

In addition, recycling, combined with improved resource-use technologies and reduced resource consumption, can significantly extend the availability of our natural resources, see box 2.

Box 2: Depleting non-renewable resources

This graph shows three possible depletion patterns for a nonrenewable natural resource. Pattern A shows what would happen to the available quantities of a natural resource if there is an expanded use of that resource. Patterns B and C illustrate that this rapid rate of depletion can be slowed down significantly by reducing consumption, and reusing and recycling products made from that raw material.

Source: Adapted from Miller, G. Tyler, Jr., *Living in the Environment Concepts, Problems and Alternatives*. Wadsworth Pub., Belmont, CA, 1975 and revised edition 1982.

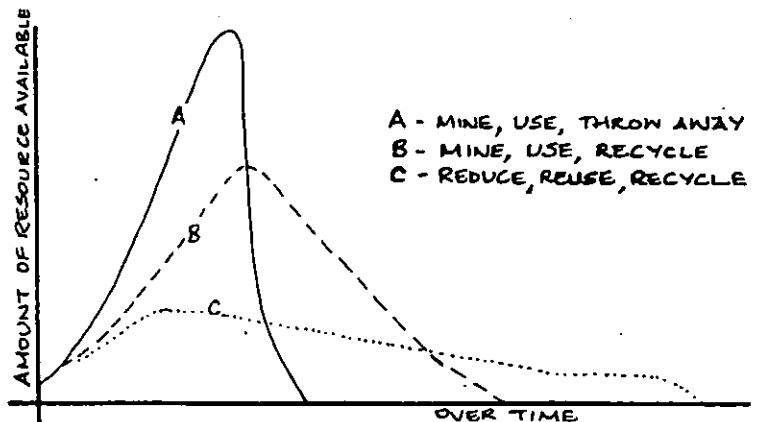

Box 3: Incineration plants

Near populated areas, large furnaces are used to burn wastes. This process of burning wastes is called "incineration". At resource recovery plants, recyclable materials are removed from the waste before it is burned. At waste-to-energy plants, the heat generated by burning the waste is used to create electricity, see diagram.

What is left after waste is burned is bottom ash at the bottom of an incinerator. There is also ash that floats up in the hot air. This is called fly ash. Fly ash can be caught in pollution control devices. Disposing of

both types, especially fly ash, is a problem because they usually contain high concentrations of dangerous toxins such as heavy metals and dioxins. Among other harmful effects, these toxins cause cancer. The ashes are generally taken to landfill sites and buried. When rain washes through the landfills, it mixes with the chemicals in the ash, forming leachate. Leachate contains toxins and can run off into nearby streams and pollute them or leak through the ground into groundwater, which may pollute drinking water.

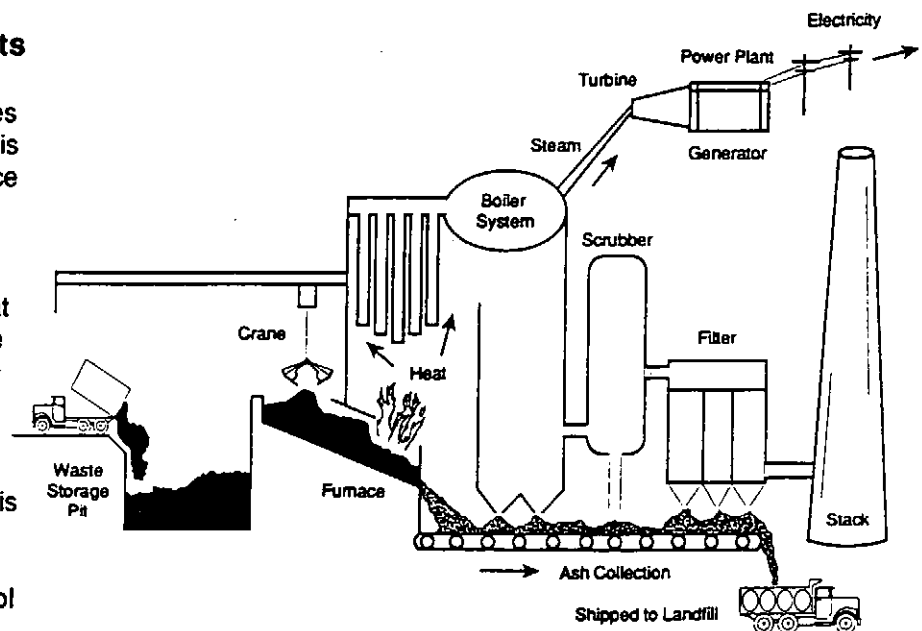

Q. Below recycling in the hierarchy is incineration. What does this mean?

A. Incineration is the burning of waste. This method reduces the weight and volume of garbage that needs to be disposed of by 50 percent and 60 percent respectively. Hence, this disposal method is especially attractive to communities that are running out of landfill sites.

Q. Does incineration have any drawbacks?

A. Yes. Most importantly, it is a destructive process that wastes both materials and energy. Though many incinerators produce energy (see box 3), the amount recovered is considerably less than that needed to produce the items they burn. For example, recycling paper can save up to five times as much energy as can be recovered through incineration, though the amount varies substantially with the type of paper.

Burning garbage is not a clean process. It produces air and water pollution and tons of toxic ash. High temperature combustion breaks chemical bonds in products containing toxic metals. These substances, left in incinerator ash and buried in landfills, can leach into groundwater. Incinerators pump into the air nitrogen and sulphur oxides (which can create acid rain), carbon monoxide, acid gases, dioxins and furans (extremely toxic substances suspected of causing cancer and genetic defects), and 28 different types of heavy metals, including lead, mercury and cadmium.

Q. Can't any of this pollution be prevented?

A. Yes. Filtering devices can trap these substances, but such equipment is expensive, and air pollution controls create additional toxic ash. Some highly toxic pollutants, including mercury, are not adequately controlled by such equipment.

Q. Does this add to the cost of incineration?

A. It certainly does. In general, incinerators are extremely expensive to build. Rough calculations using conservative figures for capital costs reveal that an \$8-billion investment in additional incinerators could allow the United States to burn one-quarter of its projected solid waste output in the year 2000. However, the same sum spent on recycling and composting

facilities could provide enough additional capacity to handle three-quarters of the nation's garbage that year.

Q. That leaves landfill as the last option for waste disposal?

A. Landfill will continue to be a major method of solid waste disposal for the near future. It is needed to handle waste that cannot be recycled or safely combusted. It is likely that there will always be some portion of waste requiring landfill no matter how efficient our reduction, recovery, treatment and recycling processes become.

We can however, greatly reduce this portion by becoming aware of our own individual contributions to the solid waste problem, and modifying our habits to promote wise use and reuse of our valuable resources.

COMIC STRIP

Learning from Nature - Want Not, Waste Not

SOURCE

Waste, 3.83 in a poster series produced by World Wide Fund for Nature - UK, Weyside Park, Godalming, Surrey, GU7 1XR, United Kingdom. If reproduced, please credit original source.

SUGGESTIONS FOR USE

Teachers: As part of class work on the natural recycling process.
Children's environment and health magazine/newspaper supplement editors: As a comic strip.

1. Lionesses - like all predators - do not know the meaning of overkill. They hunt out of hunger, and they kill sufficient prey to feed their families. Once their appetites have been satisfied, the remains of their meal (the carcass) is not wasted. Other animals, such as hyenas, follow the lionesses and arrive for their meal. These animals are called scavengers.

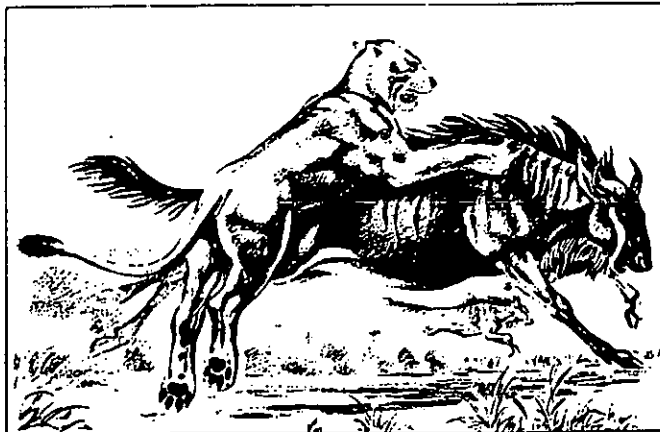

2. Virtually all hunting animals prefer an easy meal of the leftovers of another hunter's kill rather than one that involves a chase, and the hyena is no exception. The animal is a perfectly-designed waste disposal unit of the natural world: it can devour almost any fragment of a carcass except horns and teeth.



3. Another scavenger is the vulture. Different kinds of vulture feed on different parts of the carcass. Between them, the birds eat most of it, from the tough skin to soft muscles and even the marrow from bones. Within hours the bones are laid bare.



4. Once the larger animals have taken all they can from the carcass, it is the turn of the carrion flies and beetles to feed on the last of the debris. Carrion flies and beetles are called decomposers. Decomposers feed on animal waste and dead bodies of plants and animals, eventually breaking these materials down into simple raw materials which can be re-used to support plant growth.



A wildebeest, killed and partially eaten by lions, is a meal for hyenas, vultures and carrion flies.

Mike Bilsland

Bacteria and fungi are the only decomposers that can complete the chemical breakdown of complex plants and animal material into simple raw materials like oxygen, carbon, nitrogen and phosphates.

The entire process of decomposition may take many years. But without decomposers to break down waste and recycle essential raw materials, the earth would be piled high with natural litter and all life would die.

CLASS/GROUP ACTIVITY

How Does Waste Affect Our Resources?

SOURCE

The activity below is adapted from Activity 10 (K-6) and Activity 11 (7-12) in *Let's Reduce and Recycle: Curriculum for Solid Waste Awareness, Lesson Plans for Grades K-6 and 7-12* produced by U.S. Environmental Protection Agency 1980, revised 1990. The activity may be reproduced for non-profit, educational purposes in low-income countries provided credit is given to the original source. For further information, contact U.S. Environmental Protection Agency, 401 M Street, S.W. Washington, D.C. 20460, USA.

SUGGESTIONS FOR USE

Teachers/Youth Leaders: As an exercise to increase awareness of the waste of natural resources.

Community workers: Use as the basis of a poster.

1. Have the students name objects made of paper, metal, glass and a favourite type of food.

Using the blackboard or a large piece of paper, help the students trace these materials back to their source. For example, a soda bottle is made from sand mixed with soda ash and lime and melted down to form a liquid, which is then moulded into glass. See if the students can trace the origin of the other objects illustrated below. (Use the 'Resource Tree' on the next page to trace the origins of additional everyday objects.)

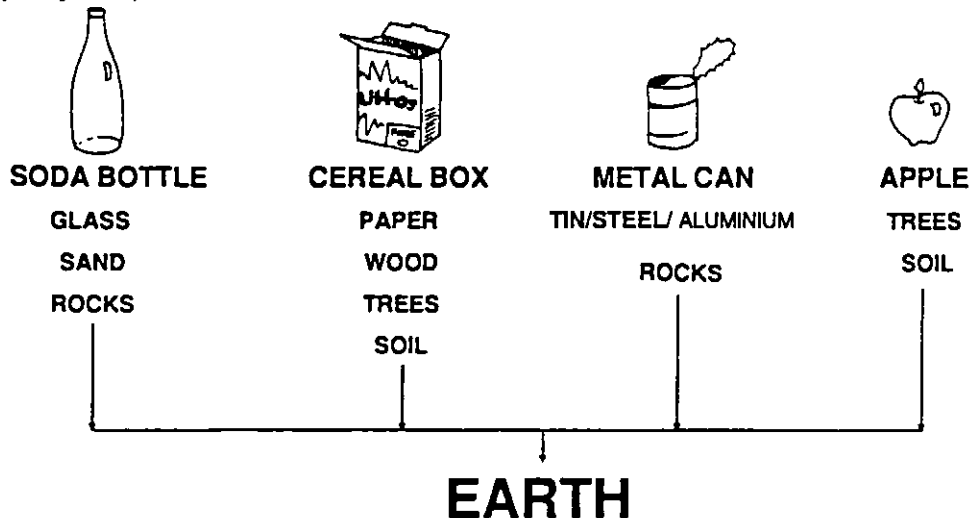

Ask the students if they can think of anything that they use that is not provided by the earth. (The children will probably name some things, but on close examination, it will be seen that these things also come from the earth.) Explain to the students that raw materials that we take from the earth are known as *natural resources*. Help the students to list the natural resources used in the above objects. Remind them that energy, which is also a natural resource, is needed to change objects from their natural forms into the products we use. Ask the students what are some forms of energy?

2. Bring into class a collection of items that would normally be discarded. With the aid of the 'Resource Tree', have the students identify the raw materials used to make each item and decide whether they are *renewable* or *nonrenewable*. In the discussion, point out that aluminium, tin, steel and petroleum are all *nonrenewable resources*. Help students understand that some materials are not renewable because they are the result of geological processes that take millions of years to complete. Nonrenewable resources are in limited supply and once they are used up, they are gone for millions of years for practical purposes.

Paper and cardboard come from the *renewable* source of wood (trees), but wood is being used up at a faster rate than it can be produced commercially. At the end of the discussion, students should be able to place any piece of solid waste into the categories of renewable and nonrenewable resources. Here are some examples:

Organic waste such as food scraps (*renewable*)

Glass bottles, from sand, soda ash and limestone (*nonrenewable, but in plentiful supply*)

Plastic containers or bags, from petroleum (*nonrenewable*)

Tin-plated steel cans, from iron and tin (*nonrenewable*)

When products are discarded, resources are wasted. Discuss ways to reduce the waste of renewable and nonrenewable resources.

RESOURCE TREE

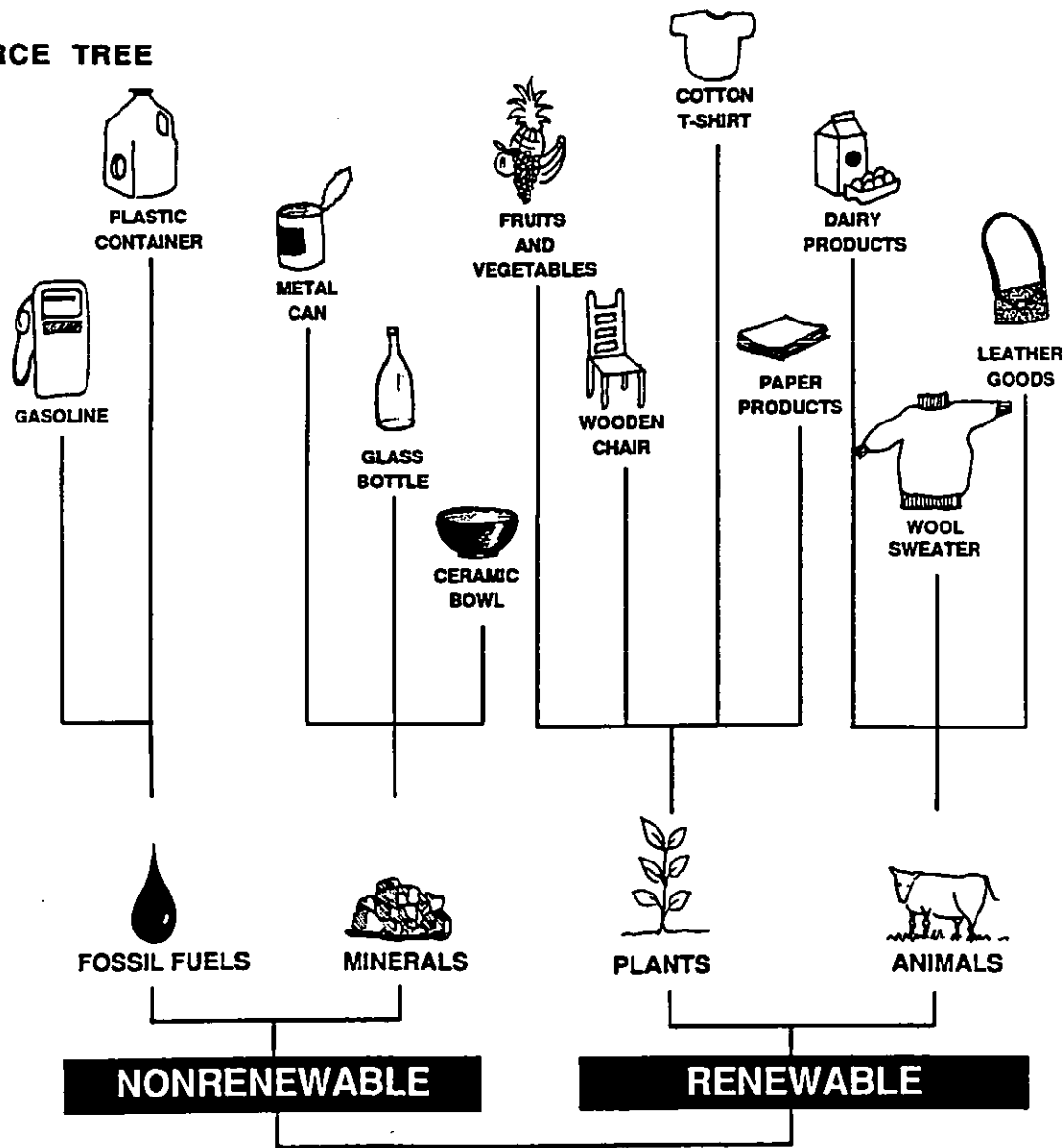

EARTH'S RESOURCES

Reduction at Source: Some Facts and Opinions

SOURCES

1. John E. Young, *Worldwatch Paper 101: Discarding the Throwaway Society* (January 1991), Worldwatch Institute, 1776 Massachusetts Avenue, N.W., Washington, D.C. 20036, USA
2. Paul Hawkin, "A declaration of sustainability", *Utne Reader* (September/October, 1993)
3. John E. Young, "Tossing the Throwaway Habit" in *Worldwatch* (Vol. 4 No. 3 (May/June 1991), published by Worldwatch Institute.
4. Christopher Flavin and John E. Young "Shaping the Next industrial Revolution" in *State of the World 1993: a Worldwatch Institute Report on Progress Toward a Sustainable Society* published by Worldwatch Institute.

If any material is reproduced, please credit appropriate original source(s).

SUGGESTIONS FOR USE

Teachers: As an activity/discussion on source reduction for older students.

Community workers: As a source of ideas for local source reduction campaigns aimed at manufacturers and consumers.

Radio broadcasters, Journalists: As awareness material on source reduction; as background material for an interview with industrialists/consumers trying to promote source reduction.

Many people think that reducing waste is impractical in today's industrial societies, but there are measures that people and industries can - or should - take to reduce both waste and production using raw materials. Read these facts and opinions on the topic, and then try the activities that follow:

- * The key to designing an economy that produces little waste is to recognise that people do not need metals, plastics, wood and other substances but, rather, the services these items provide. The amount of stone, steel or lumber used to make a house or office building, for example, is irrelevant to its occupant if the building is sturdy and stays at a comfortable temperature. Rice bought straight from a bin at a local store and carried home in an old jar is no less tasty or nutritious than that bought in a throwaway box.¹
- * One objective to achieving sustainable commerce, is that absolute consumption of energy and natural resources among developed nations should be reduced by 80 per cent within 40 to 60 years.²
- * Companies pay artificially low prices for virgin materials: this is in part because the environmental costs of making them are rarely included in the price. And virgin materials (those newly extracted from natural resources) are often subsidised by governments. Prices of products should account for the real costs of using materials. Stopping government subsidies to industry for virgin materials and levying taxes on virgin materials would provide major incentives for waste reduction, reuse and recycling.¹
- * Manufacturers need to be convinced, cajoled or forced to improve their products, so that people have the opportunity to choose items that are less harmful to the environment. And consumers need enough facts to make choices that, at first glance, might not have obvious benefits. For instance, one compact fluorescent light bulb may cost more than US\$ 15 but will last 10 times as long as an incandescent bulb, and -- since it uses one fourth as much energy to provide the same light -- can save as much as US\$ 50 in electricity bills over its lifetime.³
- * To cut waste, industrial designers can focus on developing durable, repairable products rather than the "convenient" single-use items - from razors to cameras - that now proliferate. Requiring manufacturers to replace or repair products that do not meet prescribed standards of durability could push them to design goods that last.³
- * Several companies have cut considerably the amount of waste they generate. One of the most well known examples involves Minnesota Mining and Manufacturing Corporation (3M) which began its

"Pollution Prevention Pays" programme in 1975. This programme encourages employees to find ways to reduce or eliminate use of problem chemicals -- and save money -- through the redesign of products and manufacturing processes. 3M estimates it has prevented more than 1 billion pounds of emissions since then and saved over US\$ 500 million.⁴

- * Nissan and several European car manufacturers are addressing [one] environmental issue: wasted materials. They have announced plans to build cars that will be nearly 100 per cent recyclable.⁴
- * Government mandates, consumer pressure and the rapid proliferation of recycling programmes have recently caused paper manufacturers in Europe to convert a number of mills to the use of recycled pulp, and at the same time eliminate the use of dioxin-producing chlorine bleaches. Manufacturers that once claimed recycled paper was only good for low-grade paper products are now making high-grade magazine stock at least partially from recycled fibres. Over time the industry may move away from the forested areas where it is now centred to the outskirts of large cities, where its major future resource - discarded paper - and its markets lie.⁴
- * Under pressure of higher energy prices, declining grades of iron ore, and environmental concerns, the world steel industry has been replacing its older, less efficient, more polluting mills since the [nineteen] seventies. The most rapid area of growth is in modular minimills that rely on electric arc furnaces. They are far more energy-efficient, and rely heavily on scrap steel rather than iron ore. Because they do not need to be near iron and coal resources, minimills are likely to be decentralised, and can be centres of economic development even in small cities.⁴
- * The British chemical giant ICI has built a new terephthalic acid plant in Taiwan that it claims produces virtually no chemical wastes.
- * A great challenge is to find substitutes for products that are themselves hazardous or that cannot be manufactured without using dangerous chemicals. For example, in recent decades massive use of chemical herbicides and insecticides has boosted agricultural yields. But pests have become immune to many chemicals, and toxic substances have made their way into groundwater. A number of farmers are turning to alternative forms of pest control, including Integrated Pest Management (IPM). IPM combines small, targeted applications of pesticides with careful monitoring of field conditions and the protection of predator insects. IPM often saves farmers money through reduced chemical bills. It is likely to have far-reaching consequences for agribusiness, giving rise to new firms offering IPM services. Companies may find they do better marketing "pest management" than pesticides alone.⁴
- * Consumers will reduce waste if given the incentive. Charging for garbage disposal by the garbage can or bag, or -- even better -- charging a higher rate for a second container of refuse, is a very persuasive method.³

Activities

1. Which of the above statements are facts and which are opinions?
 - (a) Select a fact, and describe how this source-reduction measure might affect your life or life in your community.
 - (b) Select an opinion, and debate the issue in class.
2. One statement says, "Manufacturers need to be convinced, cajoled or forced to improve their products." Select a product that your family uses, or a product made locally, and think of ways to improve that product so that less waste is created. For example, you might think a product should be made from recycled materials instead of virgin materials, or you might feel a product should be more durable. Then think of ways to encourage the manufacturer to adopt less wasteful manufacturing methods of production. For example, you might decide a letter-writing campaign is a good persuasion tactic. Put your ideas into action.

How Paper And Plastic Bags Are Made

SOURCE

"Bag It: the grocery dilemma" by Karen McNulty in *ScienceWorld* April 20, 1990, Vol. 46 No.16, published by Scholastic Inc. 730 Broadway, New York, NY 10003-9538, U.S.A. Reprinted by permission of the publishers. Permission to reproduce the article should be sought from the publishers, Scholastic Inc.

SUGGESTIONS FOR USE

Teachers: As reference material for lessons on use and misuse of resources.

Journalists, NGOs: As reference material for consumer campaigns to conserve resources.

Children's magazine/newspaper supplement editors: As a basis of an annotated drawing on natural resources/packaging.

Paper and plastic bags pose many environmental threats--even before they become bags. Follow the manufacture of paper and plastic bags from beginning to end to find out what pollutants and wastes are created along the way. (Both processes describe bag production from virgin materials.)

HOW PAPER BAGS ARE MADE

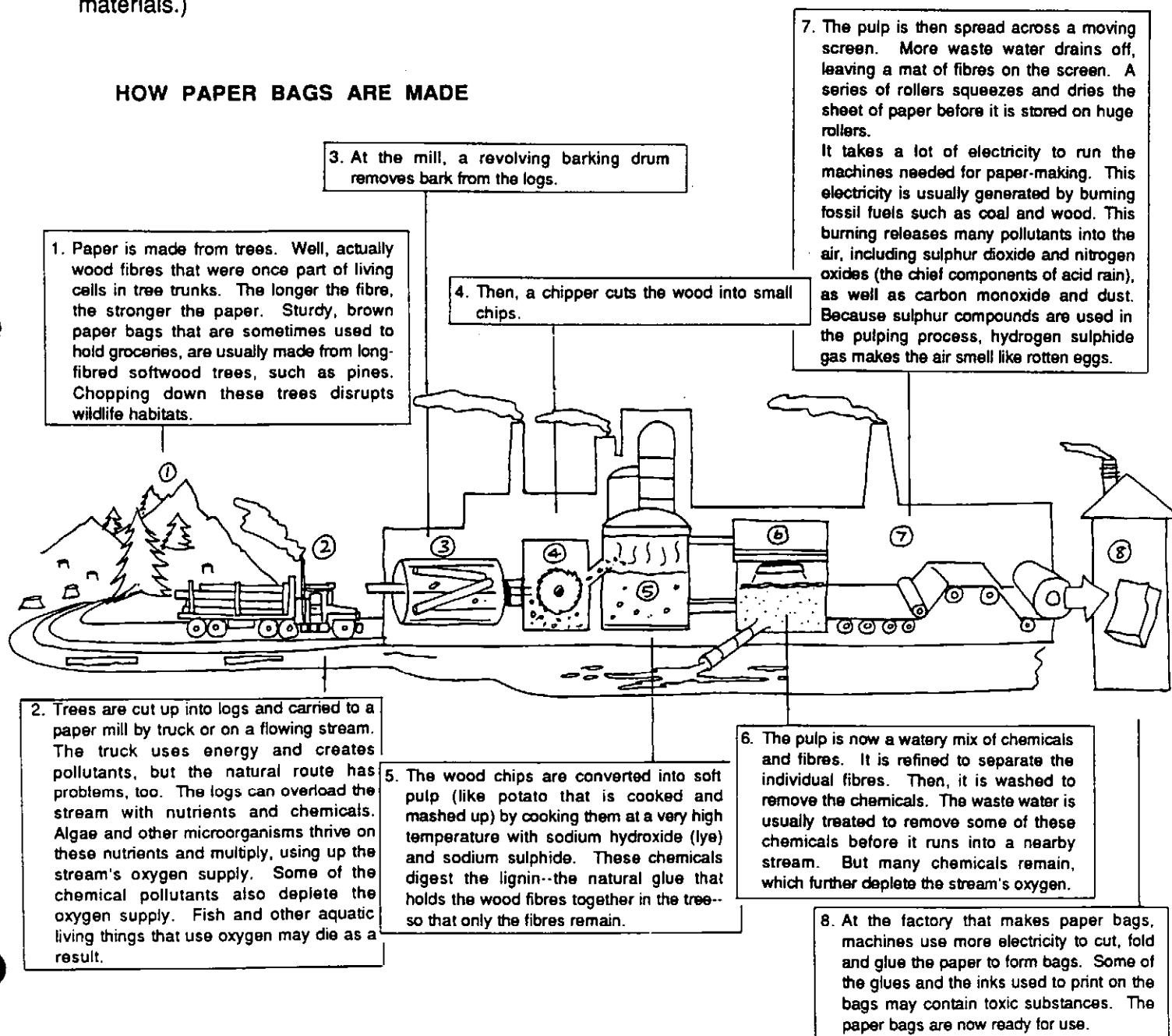

HOW PLASTIC BAGS ARE MADE

1. Plastics begin as oil or natural gas. Both oil and gas are taken from below the earth's surface, where they occur naturally but in limited quantities. Drilling for these resources may disrupt natural wildlife habitats. And, as today's reserves are used up, we will need to explore new areas, disrupting more wildlife.

3. At the refinery, oil and natural gas are refined into heating and transportation fuels. Ethane gas, a waste product from this process, is used to make plastics and other chemicals. (Otherwise it is burned off.)

6. Polyethylene is heated to form a hollow tube, and blown up with air like a balloon. The double sheet of polyethylene is then stored on large rollers. All these processes require energy obtained from burning fossil fuels such as oil. Pollutants, including sulphur dioxide, nitrogen oxides, carbon monoxide and dust are released into the air.

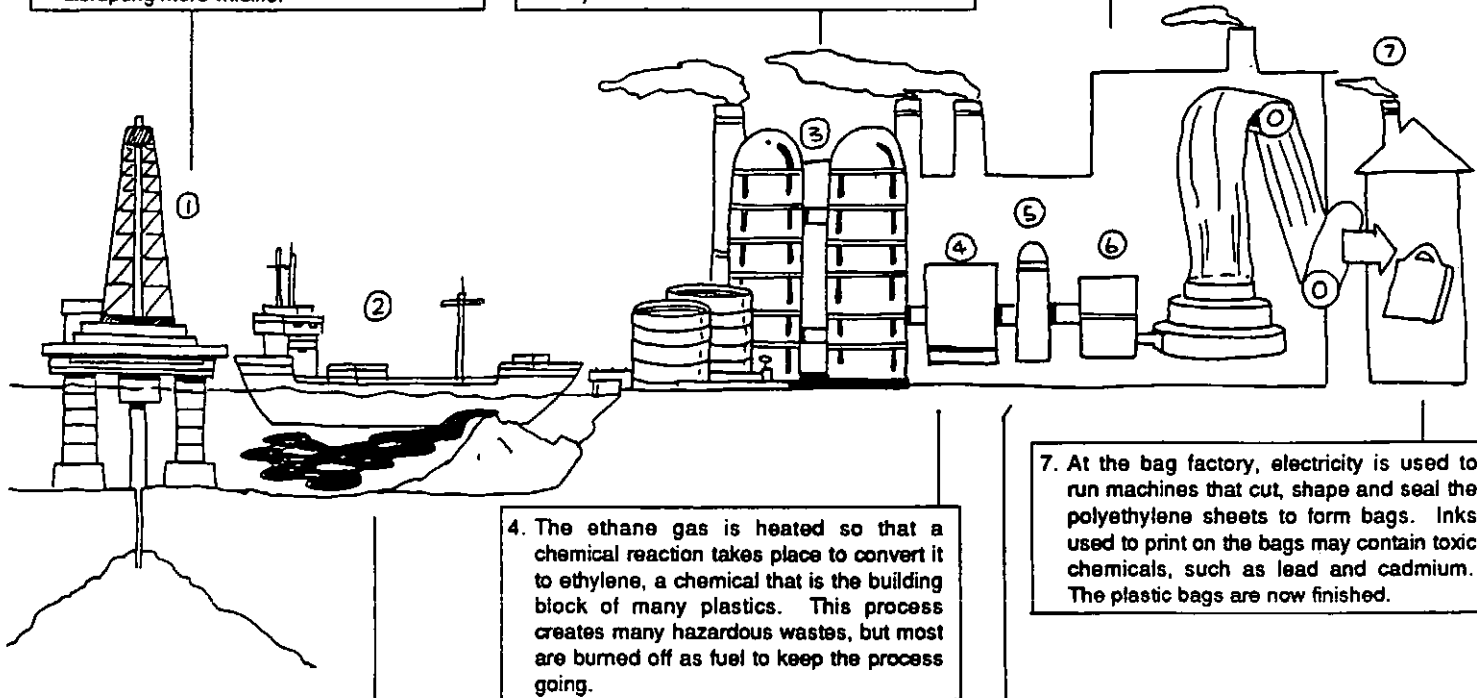

2. Transporting oil and natural gas from the drilling sites required energy. It also presents the possibility of environmental damage from accidental spill, like that from the *Exxon Valdez* off the coast of Alaska.

4. The ethane gas is heated so that a chemical reaction takes place to convert it to ethylene, a chemical that is the building block of many plastics. This process creates many hazardous wastes, but most are burned off as fuel to keep the process going.

7. At the bag factory, electricity is used to run machines that cut, shape and seal the polyethylene sheets to form bags. Inks used to print on the bags may contain toxic chemicals, such as lead and cadmium. The plastic bags are now finished.

5. When combined with other chemicals, the ethylene building blocks join together to form polyethylene -- the plastic from which plastic bags are made. The polyethylene may be mixed with additional chemicals that add strength to the plastic, or perhaps colour it. Some of the chemicals needed for these reactions are known as carcinogens--known to cause cancer. Waste water from the factory carries some of the chemicals to streams where they may be toxic to fish and other wildlife. Some of these chemicals are also released into the air.

QUESTIONS

1. What raw materials go into making a paper bag? Name one way that getting these materials might harm the environment.
2. What raw materials go into making a plastic bag? Name one way that getting these materials might harm the environment.
3. Sulphur dioxide and nitrogen oxides, the pollutants that form acid rain, are produced during the manufacture of which type of bag?
4. During the manufacture of which type of bag are carcinogenic chemicals emitted into air and waste water?

5. Which type of bag, do you think, would break down faster if it (a) were littering the street or (b) were in a landfill?
6. Which type of bag, do you think, would be more harmful if it littered places where animals lived (such as the ocean or the countryside)?

ANSWERS

1. Trees (wood fibres). Cutting down trees destroys habitats.
2. Oil or natural gas. Drilling disrupts wildlife. Oil may spill.
3. Both paper and plastic.
4. Plastic.
5. (a) Paper (b) Neither paper nor plastic breaks down in a landfill.
6. Plastic. In ocean habitats, sea birds, marine mammals, turtles and other wildlife may get tangled up in the plastics or mistake them for food. Since animals cannot digest plastic, they die. See the article, "Deadly litter chokes livestock" for the effects of plastic litter on animals.

CLASS/GROUP ACTIVITY

Packaging

SOURCE

Adapted from: *Let's Reduce and Recycle: Curriculum for Solid Waste Awareness - lesson plans for Grades K-6 and 7-12* produced by the U.S. Environmental Protection Agency, (1980, revised 1990), 401 M Street, S.W. Washington, D.C. 20460, USA. If reproduced, please acknowledge original source.

SUGGESTIONS FOR USE

Teachers, Community workers:
As an exercise to encourage students and consumers to consider packaging and ways that it can be reduced.

Have students list five examples of the following three types of packaging:

1. natural packages (*oranges, nuts*)
2. older reusable packages (*paper bags, paper wrapping, glass jars and bottles*)
3. modern packages (*plastic, polystyrene, aluminium foil*)

Make a combined list for the entire class/group. If possible, have students bring into school examples of these packages.

For each package listed, answer the following questions:

- * What purpose does the package serve?
- * Which purposes are essential? (e.g. helps keep food and drink fresh and/or free of germs; allows them to be stored and moved easily)
- * Which purposes are non-essential? (e.g. for advertising - to make an item look larger; attractive colours to make item more noticeable)
- * What is the package made of? (Label all parts including metal or plastic tops and paper labels)
- * In how many ways does the package affect the environment? (Consider the energy and raw materials needed - and the pollution created - to make the packaging, and the disposal required)
- * Can the package be reused and/or recycled?
- * How much packaging is there compared to how much product it holds? (Have students try various mathematical activities such as experimenting with weighing an empty package, then filling it with water and weighing the filled package. Compare the weight of the package with the weight of the water it holds. The lower the ratio of package to product, the less waste there is. Also, have students compare the amount of cardboard used for one large container of a product with the amount of cardboard used to hold the same amount of the same product but which is contained in several smaller packs.)
- * Why are some items packaged in small containers? (e.g. convenience; to make product affordable; to sell more for profit)
- * What's good about each package? What's not so good?

Remind the students that cutting down on product packaging or buying goods in bulk (where the ratio of package to product is low) are important aspects of reducing at source. Reusing packaging material also reduces waste.

About Aluminium

SOURCE

"Aluminium's Real Tab" by John E. Young in *World Watch* magazine, issue Vol. 5, No. 2, (March-April 1992), published by WorldWatch Institute, 1776 Massachusetts Avenue, N.W. Washington, D.C. 20036 U.S.A. The material may be reproduced for non-profit, educational purposes in low-income countries provided credit is given to the original source.

SUGGESTIONS FOR USE

Teachers: As background information for classwork on nonrenewable resources, waste.

Children's magazine/newspaper supplement editors: As source material for "Did You Know..?" articles/illustrations.

NGOs/Consumer groups: As background information for campaigns to promote source reduction.

Here are a few facts about aluminium:

- * Aluminium is a light metal: it is one third as dense as copper, brass or steel. The metal is strong, easily worked, resists corrosion, and is a good conductor of both heat and electricity.
- * Aluminium is used in the manufacture of aeroplanes, cars, in the moving parts of machinery, in electrical wiring, in building products and in packaging, especially aluminium beverage cans.
- * Aluminium is second only to iron among metals in both the quantity and value of annual production, with world sales totalling about US\$39 billion in 1990.
- * The metal's principal ore is bauxite. One third of the world's bauxite comes from Australia. Output from Guinea, Jamaica and Brazil adds up to another third. Most of the rest comes from half a dozen nations such as India, the former U.S.S.R., China and Suriname.
- * Nearly all bauxite is strip-mined. This means that miners move thousands of tons of rock and soil just to get the ore they want. Since most deposits occur as a thin layer of mineral, bauxite mining probably lays waste more land than the mining of any other metal.
- * Alumina (aluminium oxide), the material which smelters convert into aluminium metal, makes up a quarter to a half of the content of bauxite ores mined today, depending upon the richness of the ore. Extracting alumina creates large quantities of waste. For every ton of alumina extracted, a ton or more of 'red mud', a caustic soup of metallic oxides and other contaminants, is produced. Red mud is usually left to settle in large ponds adjacent to alumina refineries. It is corrosive to the skin and can pollute both surface and ground water.
- * More energy is used in the smelting of aluminium than in the processing of any other major metal. While most metals can be obtained by simply heating their ores, aluminium can be economically extracted only through a process involving the direct application of electrical current. Alumina is dissolved in a bath of molten cryolite (aluminium fluoride), to which an extremely powerful electric current is applied. The current breaks the chemical bonds between aluminium and oxygen, allowing the pure metal to be drained off. The process releases large amounts of fluorides, which if allowed to escape into the atmosphere, can cause damage to, and accumulate in, plants and animals. This can harm humans and other animals who eat these plants and animals.
- * In 1990, the world aluminium industry used an estimated 280 billion kilowatt-hours (KWh) of electricity--*nearly as much as was used for all purposes in the entire African continent*. This amount was required simply to convert alumina into 18 million tons of metal. Additional energy, most of it in the form of fossil fuels, was used to mine and refine bauxite into alumina.
- * The demand for a large and constant supply of electricity to smelt the metal makes this the single most important factor in determining where the metal is produced. Electricity prices are more critical than the location of bauxite mines or alumina refineries, since both materials can be shipped at low cost. The United States, the leading producer of the metal, imports virtually all of its bauxite.
- * The prices that aluminium smelters pay for electricity vary widely around the world, but they generally pay less--often much less--for power than other users in their area, wherever they are located. Dams have consistently provided the aluminium industry with its cheapest source of power.

- * The great bulk of aluminium is consumed by industrial nations, mainly because of their use of aluminium for packaging--much of which, despite recycling efforts, is discarded. The U.S. used 4.8 million tons of aluminium in 1990. In per capita terms, U.S. use is the highest, followed fairly closely by that of Japan and Western Europe. The average American uses about 42 pounds of aluminium each year, while the average Chinese or Mexican uses less than two pounds.
- * In many applications, such as aeroplanes, trains and automobiles, aluminium can save more energy over a lifetime of use than is required for its manufacture. Using aluminium instead of iron and steel has played an important role in increasing the fuel efficiency of vehicles. A typical car now contains 140 pounds of aluminium, and the amount is expected to more than double by the year 2000.
- * Because it is the extraction of aluminium from bauxite that takes so much energy, recycling the metal would result in considerable energy savings. To make aluminium from scrap takes only about 6 per cent of the energy needed to produce aluminium from ore.
- * More than 5 million tons of aluminium--nearly a quarter of world output--was produced from recycled metal in 1990. Japan gets about 40 per cent of its aluminium from recycling. Recycled aluminium makes up about 20 per cent of U.S. consumption, and 20 to 30 per cent of the metal used in Western Europe. In most developing countries, though data is scarce, recycling probably accounts for an even larger share.
- * The country with the highest recycling rate is not necessarily the most efficient user of aluminium. The U.S.A. recycles half its aluminium beverage cans. Yet the amount of aluminium, in the form of beverage cans, that the country throws away is still greater than the total use of the metal by all but seven nations.
- * In the article, "Aluminum's Real Tab", author John E. Young claims that the best way to encourage recycling and discourage environmentally-inappropriate uses of aluminium would be to make industry pay its own way. If aluminium makers no longer had artificially low energy prices, there would be strong incentives to recycle aluminium and to limit the metal's use to energy-saving applications.

CLASS ACTIVITY

Not everything made from scratch is the best

SOURCE

Adapted from Groundwater Resources and Educational Activities for Teaching - GREAT produced by Iowa Department of Natural Resources (USA). It may be reproduced for non-profit, educational purposes in low-income countries provided credit is given to the original source. GREAT is a six-unit science-based curriculum (for 12 to 14 year-olds) dealing with groundwater protection in the state of Iowa, USA, including the impacts of hazardous wastes and substances on groundwater.

SUGGESTIONS FOR USE

Teachers: As the basis for a class discussion on production using virgin materials.

Study the chart and then answer the questions that follow.

Recipe for one ton of Aluminium

Ingredients

81,766 lbs. bauxite
 11,020 lbs. petroleum coke
 966 lbs. soda ash
 327 lbs. pitch
 238 lbs. lime

Pollutants Generated

3,290 lbs. red mud
 2,900 lbs. CO₂
 81 lbs. air pollutants
 789 lbs. solid waste

Process with 197 million BTU's of energy.

Note:

1 short ton is 2000 lb which equals 0.91 metric tonnes. A BTU is a measure of energy and is defined as the amount of energy needed to raise 1 pound of water 1 degree Fahrenheit.

1. How many pounds of material are required to make one ton of aluminium?
2. What is the ingredient that is used in the greatest quantity?
3. What is the pollutant that goes into the air in the greatest quantities? Is this pollutant harmful to our environment? If so, how?
4. Does the recipe include any other nonrenewable resources? If so what are they?
5. Besides the 197 million BTU's needed to actually make the aluminium, in what other ways do you think energy was used in the whole process of getting aluminium from the earth to the consumer?
6. Aluminium can be recycled for approximately 94% less energy than it takes to produce it from "scratch". Besides this saving in energy, what do you think might be five other benefits of recycling aluminium rather than manufacturing it from bauxite?

Answers:

1. 94,317 lbs
2. Bauxite
3. Carbon dioxide. It is necessary for plant growth, but it can become harmful if too much collects in the atmosphere and traps the heat, producing the Greenhouse Effect.
4. Petroleum coke and pitch.
5. Energy is also used in mining bauxite and other materials, transportation of raw materials to the processing plant, transportation of processed aluminium to the manufacturing plant, and transportation of the product to the consumer (sometimes through various distributors).
6. Recycling benefits include: conservation of land from mining practices; reduction in solid waste; reduction in litter; conservation of nonrenewable resources; reduction in air pollution; reduction in water pollution from mining practices and from less use of waste disposal (e.g. landfills).

CLASS/GROUP ACTIVITY

The Life Cycle of a Discarded Product

SOURCE

Adapted from: *Let's Reduce and Recycle: Curriculum for Solid Waste Awareness - lesson plans for Grades K-6 and 7-12* produced by the U.S. Environmental Protection Agency, (1980, revised 1990), 401 M Street, S.W. Washington, D.C. 20460, USA. If reproduced, please acknowledge original source.

SUGGESTIONS FOR USE

Teachers, Community workers: As an awareness exercise to help students and community groups review solid waste problems and ways that they can be reduced.

In this activity, students research the "life-cycle" of a particular type of waste. Divide the class into groups and assign one of the types of waste listed below to each group. Give each student a copy of the questionnaire below to help them tell about their particular resource. Then, have them present their findings to the class:

Plastic tube

Cardboard box

Tin can

Glass bottle

THE STORY OF THE _____

1. What does it look like?
2. Why does it have a label?
3. What are some of the things it is used for?
4. What is it made of?
5. Where does the manufacturer get the raw materials to make it?
6. Are large amounts of these raw materials available?

7. How many years will it be before these raw materials run out?
8. Does the process of extracting these raw materials from the earth pollute the land, the air, or the water? If so, how?
9. How do manufacturers change the raw materials to make the product?
10. Does the changing of the raw materials pollute the land, the air, or the water? If so, how?
11. Is the item thrown away after it is used?
12. What effect would this item have if it was littered on the ground or in a body of water?
13. What chemicals are released when it is burned? Are they harmful if released into the environment? Can they be filtered and disposed of properly?
14. Does the item break down into earth again if it is buried? If so, how?
15. Does it disintegrate if thrown into a river, lake, or ocean? If so, how?
16. What are some ways in which it could be reused?
17. Can it be recycled? Is it currently recycled? Where?
18. How is it recycled?
19. Can it be safely burned to produce energy from heat?
20. Who pays the real cost for manufacturing this item?
 The manufacturer who makes it?
 The company that uses it?
 The consumer who buys it?
21. Who is responsible for disposing of it? Who pays the cost for disposal?
22. Do you think this item makes a good container? Why or why not?
23. Could we have avoided using this container? How?

CLASS/GROUP ACTIVITIES

Don't throw away - Reuse

SOURCE OUTREACH	<p>SUGGESTIONS FOR USE Teachers, Youth/Community leaders: Use as activities to increase awareness of waste, and to encourage inventiveness.</p>
----------------------------	--

A lot of products can be reused instead of being thrown away. Containers such as paper and plastic bags, glass jars, plastic bottles, cans and boxes can be used to serve another purpose. Containers of all shapes and sizes have more than one life. Here are three activities that encourage students to reuse products:

1. Ask children how many uses they can think of for the following items:
 a large empty jam jar an empty tin can bicycle spokes
 Have them try out their suggestions.
2. Set up a "use-it-again" box in your classroom. Have the children paint, colour or paste pictures on it. Suggest that children place in it all materials that can be used again. Encourage children to contribute to the "use-it-again" box on a day-to-day basis. For example, paper that has been used on one side can be used again; materials such as thread spools, paper bags, grocery boxes,

- empty tin cans (washed) can also be brought from home for school arts and crafts and games.
3. Have the class/group draw up a list of household items that might need repairing, together with names of local people with expertise in doing these types of repair and who would be willing to 'barter' their services. Place this list in a local community noticeboard.

ACTIVITY

Tin Can Football

SOURCE

Reprinted from: *BOTHER* issue No. 136 (September - October 1985) "Do It Yourself: Recycling for a Fairer World" published by Oxfam's Youth and Education Dept., 274 Banbury Road, Oxford, OX2 7DZ, United Kingdom. The material may be reproduced for non-commercial, educational purposes in low-income countries provided credit is given to Oxfam.

SUGGESTIONS FOR USE

Teachers, Youth leaders: As part of a waste awareness project.

Children's magazine/newspaper supplement editors: To include in an issue on waste.

Why not collect enough small tins to play this game from Ghana?

The pitch is marked out on the ground with a stick. The players collect 24 empty small Ideal milk cans (small baked bean or other cans will do). Take the labels off 12 of the tins, leaving 12 with their labels on. This makes two teams of 10 players plus four goal posts. Two sardine cans on their sides act as goalkeepers. Each player arranges his or her team as they like at the start of the game and doesn't move them. The ball is a pebble or bean, placed in the centre. A coin is tossed to decide who kicks off, and player one flicks the pebble towards their opponent's goal. If it hits one of player one's own tins they can flick it again. If it hits one of the other team's

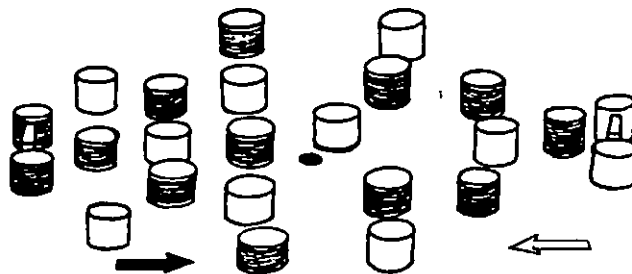

tins, then player two has a flick. Football rules apply for corners, goal kicks, throw ins, offsides etc. Tins that have been hit by the pebble and moved are left in that position. If they are knocked over or off the pitch they are then replaced.

ACTIVITY

Composting Waste

SOURCE

Adapted from *Composting: Wastes to Resources*, a Cornell Cooperative Extension Publication by Jean F. Bonhotal and Marianne E. Krasny. The activity may be reproduced for non-profit educational purposes in low-income countries if credit is given to the original source. For further information on this publication, contact Media Services Distribution Center, 7 Cornell Business and Technology Park, Cornell University, Ithaca, New York 14850 U.S.A. Tel: (607) 255 2080

SUGGESTIONS FOR USE

Teachers: As practical exercises in project work on waste and recycling.

Community workers, NGOs: For adaptation and use in leaflets and community projects encouraging composting.

Composting occurs naturally nearly everywhere. Animals die, leaves drop from trees. Over time these organic materials break down or decompose. The rich, dark, soil-like material that results is called compost.

Tiny living things (microorganisms) such as bacteria and fungi, break down organic matter to form compost. Worms and other soil creatures help, too. As microorganisms and soil animals turn organic materials into compost, they use the organic materials as food for their own growth and activity. Eventually, these nutrients are returned to the soil, to be used again by trees, crops and other plants. This is nature's way of composting -- and recycling.

Through composting, organic materials - such as kitchen or garden wastes - can be put back into the environment and used by other living things. In this way, wastes become valuable resources.

A COMPOST RECIPE

Composting is like baking. Simply add the ingredients, stir, "bake" and out comes--compost!

Ingredients

Add a mixture of some or all of the following ingredients:

Kitchen Compost

- * vegetable peels and seeds
 - * fruit peels and seeds
 - * coffee grounds
 - * egg shells
 - * nut shells
 - * any other vegetable or fruit scraps
- (Do not add meat scraps, bones, oils, fats, dairy products. They may attract animal pests.)

Garden Compost

- * hay or straw
- * cut grass
- * leaves
- * ashes
- * sawdust
- * wood chips
- * weeds and other garden waste
- * manure
- * shredded paper

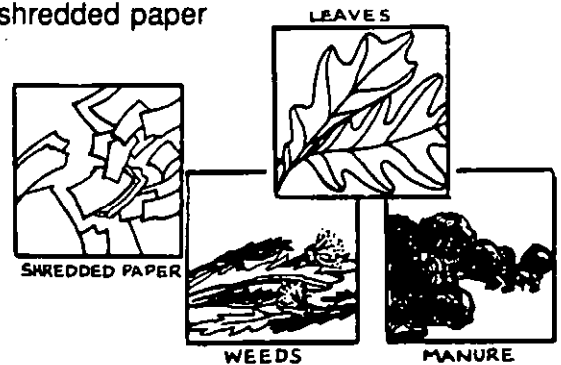
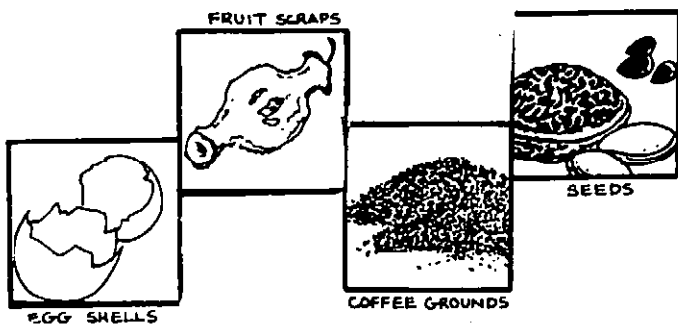

(Kitchen and garden wastes may be composted together, but the combination may attract rodents.)

Directions

1. Choose a container for "baking" your compost. Any type of bin will do. The picture below shows one type of bin. It is a wire mesh bin made from inexpensive galvanised chicken wire. To make the bin, 12½ feet (about 4 metres) of chicken wire is stood in a circle, and held together with heavy wire.
2. Chop and shred organic material if you want them to compost quickly. Place kitchen or garden wastes into the composting bin.
3. Spread soil or "already done" compost over the compost pile. This layer contains the microorganisms and soil animals that do the work. It also helps stop the surface from drying out.
4. Adjust the moisture in your compost pile so that the materials are damp to touch but not so wet that drops come out when you squeeze it.. Add dry straw or sawdust to soggy materials, or add water to a pile that is too dry.
5. Allow the pile to "bake". It should heat up quickly, and reach the desired temperature (90° to 140°F or 32° to 60°C) in four to five days.
6. Stir your compost as it bakes if you want to speed up the baking time. If you turn your compost

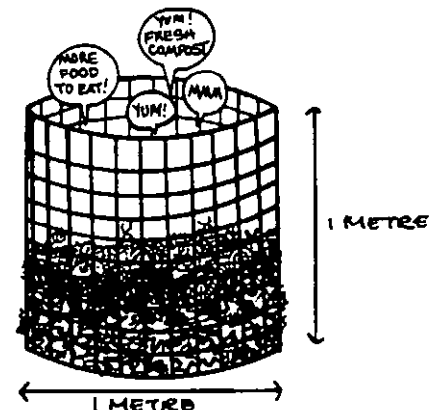

- pile every week, it should be "done" or ready to use, in one or two months.
7. The pile will settle down from its original height. This is a good sign that the compost is baking properly.
 8. Your compost should look like dark crumbly soil mixed with pieces of organic material. It should have a sweet, earthy smell.
 9. Feed compost to hungry plants by mixing it with the soil.

For more on composting, see OUTREACH Learning-By-Doing Leaflet no.9 "Brown Gold for your Garden".

ARTICLE

Worm Composting (or, save your back and let the worms do it) by Mary Appelhof, illustrations by Mary Frances Fenton

SOURCE

Adapted from *Worms Eat My Garbage* by Mary Appelhof and from flyers of Flowerfield Enterprises, 10332 Shaver Road, Kalamazoo, Michigan 49002 (USA) by permission of Mary Appelhof. The article may be reproduced for non-profit educational purposes in low-income countries provided credit is given to the original source.

SUGGESTIONS FOR USE

Teachers, Youth Leaders, Community workers: As an introduction to projects on worm composting.
NGOs, Journalists, Radio broadcasters: To use in pamphlets, articles and programmes to encourage people to start vermicomposting.

Organic kitchen waste can create unpleasant odours when allowed to accumulate. Disposal may be expensive, and can create environmental problems. For example, hazardous methane gas, produced by decomposition of organic waste buried years ago may leak from landfill sites. Why bury organic waste when such problems can result, and when our soils need the nutrients? Taking care of your own food scraps makes sense in many ways, and worm composting provides an effective way to do so.

Worm Composting basics

A worm composting system consists of:

- (1) a suitable container;
- (2) bedding;
- (3) worms;
- (4) a proper environment.

Organic waste is buried in the bin. The worms, along with millions of microorganisms, break down the waste and transform it to black, odourless, nutrient-rich worm castings. These worm castings can be used to fertilise plants in the garden and field. The process is simple, convenient and environmentally-sound.

The Technique

A worm bin can be made from a number of different types of containers, such as a wooden box or specially-designed aerated plastic bin such as a Worm-a-way®. What is important is that the container is shallow -- no more than 12 inches (30 cm) deep -- and has a large surface area, see right. This allows as much bedding as possible to be in contact with air. Oxygen is necessary for worms and microorganisms to break down the waste. The size of the bin depends upon how much organic waste you need to

Working out the surface area of a worm bin

The surface area of the wooden box below is:
2' x 4' = 8 square feet
(or 1.24 m x 0.62 m = 0.76 m²)

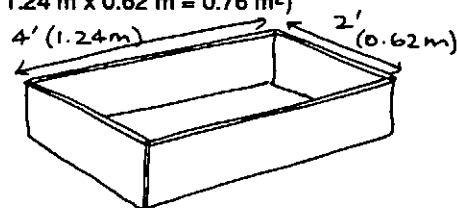

compost. A worm bin 1 foot by 2 feet by 3 feet (30 cm by 60 cm by 90 cm) can handle an average of 6 lb (2.7 kg.) of kitchen waste per week. If you use an existing container, make sure that it has not been used to store chemicals, such as pesticides, which may kill the worms. (For more information, see How to make a worm bin on page 22).

The worm bin is filled with moistened bedding. Suitable beddings hold moisture and provide an aerobic environment and some food for the worms. Shredded newspaper, leaf mould, manure or mixtures of these materials make satisfactory bedding. The bedding should be damp, not wringing wet (about 75% moisture).

To find worms that are suitable for composting, look in habitats such as damp leaf litter, under logs and stones, in piles of manure and in compost piles. Do not expect soil-dwelling worms that you might dig up in your garden to work as well in a worm bin as those which normally live in high concentrations of organic material. Redworms

(*Eisenia fetida*) are ideal worms for composting. (For other appropriate species, see right.)

In the worm bin, worms are placed on top of the bedding, and are allowed to work down into it. A rule of thumb is to set up a worm bin with about 1 lb (0.45 kg.) of worms for every 1/2 lb (0.23 kg.) of food waste produced per day. That does not mean that everything you bury today will be gone tomorrow, but over time, you won't recognise it because the worms will have turned it into rich, black humus.

Worms suitable for vermicomposting in tropical areas

The following species, in addition to *Eisenia fetida*, might be suitable for vermicomposting in tropical areas:

Eudrilus eugeniae; *Dichogaster bolau*;

Perionyx excavatus; *Lampito mauritii*;

Octochaetona surensis; *Drawida willsi*

Source: Dr. John W. Reynolds, Chair, Resource Technology Division, Sir Sandford Fleming College, Lindsay, Ontario, Canada K9V 5E6

What to bury

All kinds of organic waste can go into the worm bin, although you should not include bones and meat scraps. You can use shredded orange and lemon rinds, lettuce and cabbage leaves cut into tiny small pieces, potato peels, tea leaves and coffee grounds. Egg shells add calcium and other nutrients. The shells break down faster when pulverised with a stone.

People expect to find offensive odours when they start burying all their waste in a small worm bin. Yet users express surprise at how little odour there is. You can reduce odour problems by disturbing the bedding as little as possible when burying waste, by covering the food scraps with bedding and by depositing waste in different locations each time.

A loose plastic cover helps to retain moisture in a wooden worm bin. With a covered plastic bin, drying out of the bed is not usually a problem. Additional bedding is added every month or so, and worms are transferred to new bedding every four to six months.



Free fertiliser – healthy plants

The product from a worm bin is vermicompost, a mixture of worm castings, partially decomposed waste and uneaten bedding. Vermicomposting can be used as an immediate source of fertiliser for transplants, seed beds and garden plants.

Plants fertilised with worm castings thrive, providing beauty, pleasure and good food. Plant and food residues can again be fed to the worms to be recycled in a convenient, natural and environmentally-sound way.

Two tips for vermicomposting in tropical areas: (1) Place a damp cloth over the worm bin. The evaporation of water from the cloth will have a cooling effect on the worm bin if it is placed in a well-ventilated location. (2) Keep ants at bay, by standing your composting bin on legs, and have these legs stand in open cans that contain oil.

People knowledgeable on earthworm biology are:

- * Dr. M.C. Dash, Environmental Biology Section, School of Life Sciences, Sambalpur University, Jyoti Vihar - 708 019, Orissa, India
- * Dr. Adrian J. Reinecke, Departement Soologie, Fakulteit Natuurwetenskappe, Universiteit van Stellenbosch, Stellenbosch, C.P. South Africa.
- * Dr. A. O. Segun, Department of Zoology, Obafemi Awolowo University, Ife-Ife, Nigeria
- * Dr. Patrick Lavelle, Ecole Normale Superieure, 46 rue d'Ulm, Paris, France F-75230

Source: Dr. John W. Reynolds, Chair, Resource Technology Division, Sir Sandford Fleming College, Lindsay, Ontario, Canada K9V 5E6.

ACTIVITY

How to Make a Worm Composting Bin

SOURCE

Adapted from *Composting: Wastes to Resources*, a Cornell Cooperative Extension Publication by Jean F. Bonhotal and Marianne E. Krasny. The activity may be reproduced for non-profit educational purposes in low-income countries if credit is given to the original source. For further information on this publication, contact Media Services Distribution Center, 7 Cornell Business and Technology Park, Cornell University, Ithaca, New York 14850 U.S.A. Tel: (607) 255 2080

SUGGESTIONS FOR USE

Teachers: As a practical exercise in project work on waste and recycling.

Community workers, NGOs: For adaptation and use in non-profit leaflets and community projects encouraging composting.

With the help of worms, you can turn kitchen waste into compost! You can keep worms in a box and have them digest household scraps. The box gives off little odour. Worms can be kept in a worm composting bin in apartment buildings or other homes with no outdoor space.

What You Need

Please note metric conversions:

1 inch (1") = 2.54 centimetres; 1 foot (1') = 0.31 metres;

1 lb = 0.45 kg.

1 pint = 0.47 litres; 1 US gallon = 3.8 litres.

Materials:

- * 1 4-x-8 foot sheet of 1/2-inch exterior plywood (exterior grade plywood is used since the box will be damp most of the time, and you do not want the layers separating from each other)
- * 1 11-foot length of 2" x 4" (2-by-4) lumber
- * 1 13-foot length of 2" x 4" (2-by-4) lumber
- * 1/2 pound of 6d galvanised nails
- * 2 galvanised door hinges
- * optional: 1 pint of clear varnish or polyurethane
- * optional: plastic sheets for placing under and over the bin
- * 1 pound of worms for every 1/2 pound of food wastes produced per day
- * bedding for worms: moistened shredded newspaper or cardboard, peat moss or brown leaves.

Tools:

- | | | |
|----------------|-----------------------------|---------------------------|
| * tape measure | * long straight-edge ruler | * possible |
| * handsaw | * screwdriver | * work gloves if possible |
| * hammer | * drill with 1/2-inch bit | * optional: paint brush |
| * saw horses | * eye and ear protection if | |

1. Measure and cut the plywood as shown so you have one 24-x-36-inch top, one 23-x-36-inch base, two 16-x-24-inch ends, and two 16-x-36-inch sides.

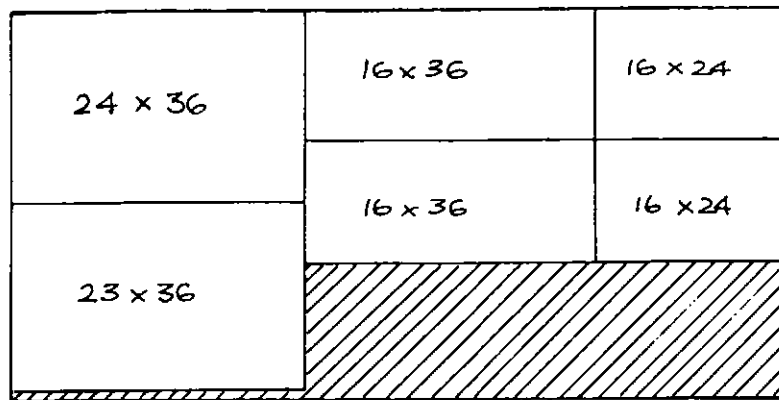

2. Cut the 11-foot length of 2-by-4 lumber into five pieces: two 32-inch pieces, two 23-inch pieces, and one 19-inch piece.

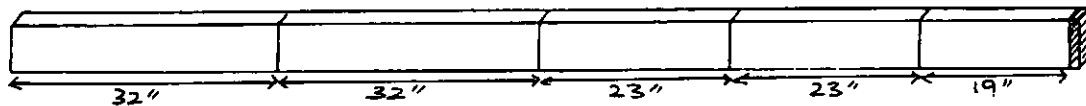

3. Lay the five pieces on edge on a flat surface to form a rectangle with the long pieces on the inside and the 19-inch length centred parallel to the ends. Nail the pieces together with two 6d nails at each joint.

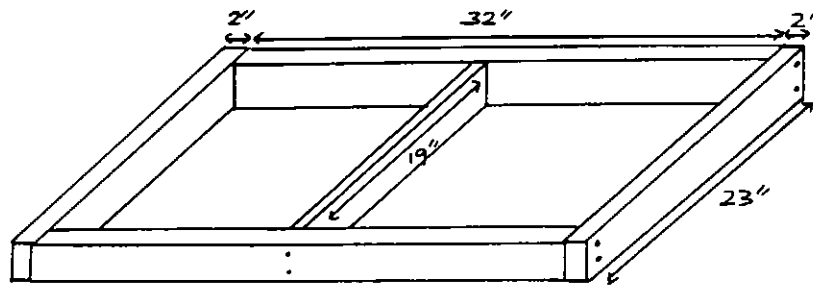

Legs, made of 2-by-4s, can be added to allow air to circulate underneath the box, see step 9.

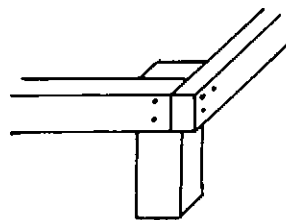

4. Nail the 23-x-36-inch piece of plywood onto the frame with 6d nails every 3 inches.

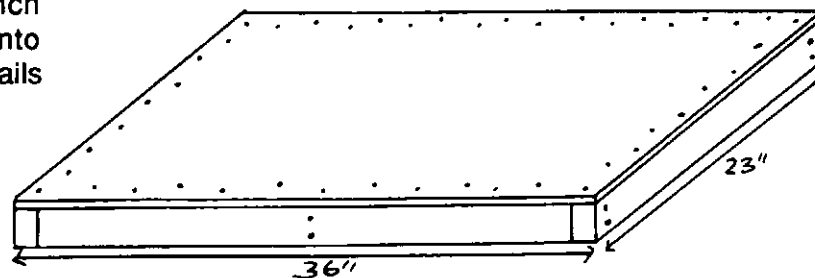

5. Cut four 1-foot lengths from the 13-foot length of 2-by-4 lumber. (Save the remaining 9-foot piece.) Take the two 16-x-36-inch pieces of plywood and place a 1-foot length flat against each short end, and flush with the top and side edges. Nail the 2-by-4s in place using 6d nails.

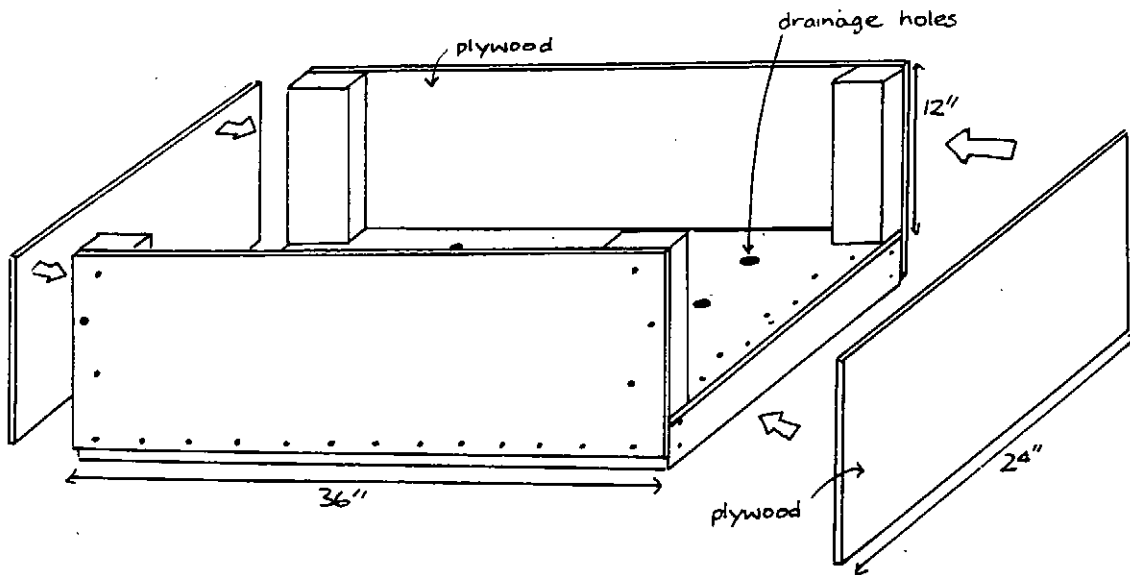

6. Set the plywood sides up against the base frame so the bottom edges of the 2-by-4s rest on top of the base frame and the bottom edges of the plywood sides overlap the base frame. Nail the plywood sides to the base frame using 6d nails, see picture above.
7. To complete the box, nail the 16-x-24-inch pieces of plywood onto the base and sides at each end, see picture above.
8. To reinforce the box, make sure a nail is staggered at least every 3 inches wherever plywood and 2-by-4s meet.
9. Drill 12 one-half-inch holes through the plywood bottom of the box for drainage and aeration, see picture above. These bottom holes make it necessary to place the bin on legs or casters to allow air to circulate underneath, see step 3.

10. To build the frame for the lid, cut the remaining 9-foot piece of the 13-foot length of 2-by-4 lumber into two 39-inch pieces and two 19-inch pieces. Lay the pieces flat to form a rectangle, with the short pieces on the inside.

11. Lay the 24-x-36 inch piece of plywood on top of the lid frame so the plywood is 1 1/2 inches inside all the edges of the frame. Nail the plywood onto the frame with 6d nails.

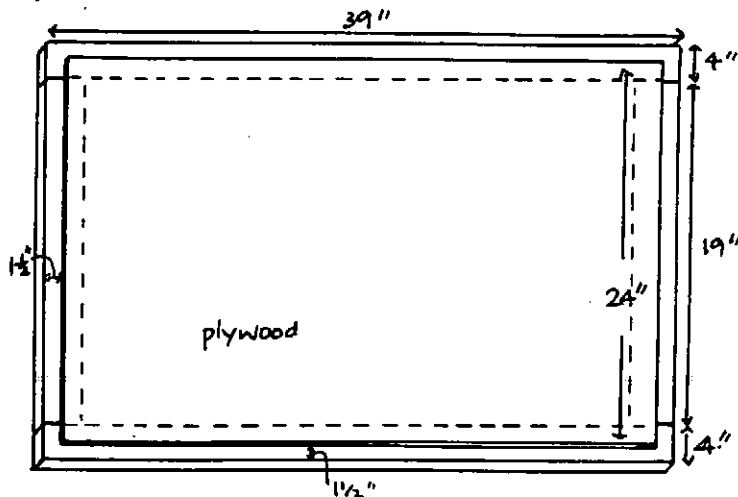

12. Attach the hinges to the inside of the back of the box at each end (on the 2-by-4) and the corresponding undersides of the back edge of the lid frame, so the lid stands upright when opened.
13. The unfinished box should last two or three years. Finishing the box with varnish or polyurethane, however, will protect the wood and prolong the life of the box. Two coats of

varnish with a light sanding between coats should be sufficient.

14. Find a good location for the box. It can be placed anywhere as long as the temperature is more than 50°F (10°C). The most productive temperature is 55° to 77°F (13° to 25°C), not in direct sunlight. Make sure to place the box where it is convenient for you to use, It is wise to place a plastic sheet under the box.

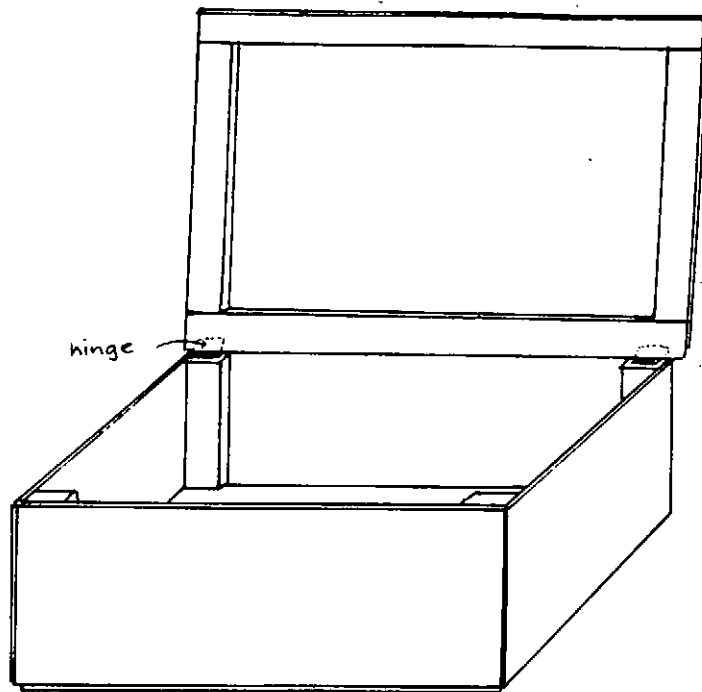

RESOURCES AND ACTIVITIES

Worm Composting

SOURCE

Flowerfield Enterprises, 10332 Shaver Road, Kalamazoo, MI 49002 USA.
The activities provided may be reproduced for non-profit, educational purposes in low-income countries provided credit is given to the original source. All materials, and further information, are available from Flowerfield Enterprises.

SUGGESTIONS FOR USE

Information for anyone embarking of a vermicomposting project.

WORMS EAT MY GARBAGE by Mary Appelhof published by Flower Press (1982, ISBN No. 0-942256-03-4) (100 pages, US\$10.50 post paid, surface rate)

Worms Eat My Garbage provides detailed instructions on how to set up and maintain a home vermicomposting system.

WORM-A-WAY® (only available in U.S.A. and Canada)

Worm-a-way® is a an indoor composter that can be used to break down kitchen scraps quickly, conveniently and with a minimum of odours. Designed by Mary Appelhof, each patented Worm-a-way® is a ruggedly constructed plastic composter with a snap-on lid. It is manufactured from recycled materials, and its assembly provides jobs for developmentally-disabled adults working in a sheltered workshop.

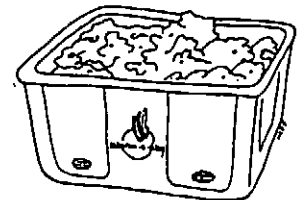

WORMS EAT OUR GARBAGE: Classroom Activities for a Better Environment by Mary Appelhof, Mary Frances Fenton and Barbara Loss Harris, published by Flower Press (1993, ISBN 0-942256-05-0) (232 pages, 400 illustrations, US\$22.00 post paid, surface rate)

Worms Eat Our Garbage is a curriculum guide and activity book, and while it is aimed at elementary and middle school grades, its potential use extends far beyond. Anyone wishing to learn more about earthworms as well as nature's recycling process, will be well served by this publication.

A wealth of biological information is presented in Wormformation boxes that precede activities. The activities encourage problem-solving. Self-discovery is stimulated. Many experiments are open-ended. Each activity stands alone or may be utilized with other activities to suit the teacher's goals. While activities are primarily for science education, the materials incorporate a multitude of disciplines including mathematics, geography, environmental history, and creative writing.

Two sample activities from *Worms Eat Our Garbage* are shown on the next page.

Name _____

Observing the Bin

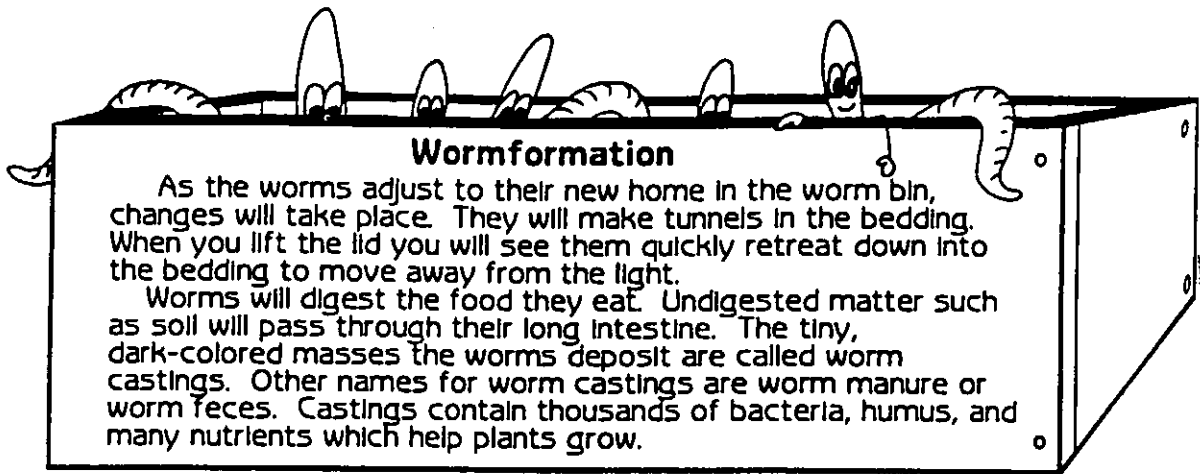

Directions

Observe changes in your worm bin. Write your observations in the spaces provided.

1. Find a worm casting. Where did you find it? Describe the worm casting.

2. Dig in the oldest garbage burying spot. What do you see? _____

3. Dig in the most recent burying spot. What do you see? _____

4. Compare your observations in #2 and #3. How are they alike and how are they different?

Bonus Activity Repeat the above observations in three weeks and compare the differences.

Directions

To find out how many worms are in a bin after several months, you will need to harvest them and change their bedding. Follow these steps. Before doing each step, predict what you think will happen. After completing the step, record your observations of what did happen.

Materials needed

- 6' x 6' sheet of heavy plastic
- container for worms
- heavy plastic bag for compost
- fresh bedding

What do I predict?

How will it feel?

Where are the worms?



How will it smell?

Did the worm population increase?

Were my predictions correct?

What will happen to the worms?

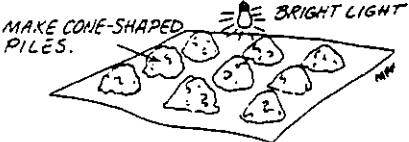
What will I see?

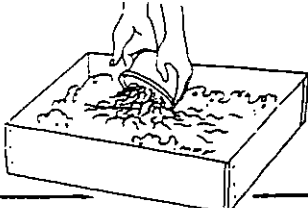
STEPS	PREDICTIONS	OBSERVATIONS
<p>Spread the plastic on the ground or table. Dump the contents of the worm bin onto the plastic.</p>		
<p>Make about nine cone shaped piles. Shine the light on the piles.</p> 		
<p>Scrape the vermicompost from the top of each pile. Place the compost in a container to use on garden and house plants.</p> 		
<p>Place the worms in a container. Count the worms. Weigh the worms.</p> 		
<p>Add the worms to bin with new bedding.</p> 		

Happy Harvest Ideas: Discuss the advantages and disadvantages of this method of harvesting worms. The advantages are that you can save a majority of the worms, keep good data (weigh and count worms), find cocoons to put back in the bin, harvest castings for the garden crops, and harvest worms for fishing or to start a new worm bin. The major disadvantage of this method is that it is time-consuming.

Make Compost in Small Pits in the Garden

SOURCE

Developing Countries Farm Radio Network Package 20 Item No.7
 If reproduced, please give credit to: Developing Countries Farm Radio Network
 DCFRN is a worldwide information network that gathers farming information from developing countries and provides information in the form of broadcast material for communicators in developing countries. The network aims to help small farmers increase their food supply for their families, or to sell. The Network is supported by the Canadian International Development Agency, and hundreds of individual, corporate and foundation donors. For further information, contact: Developing Countries Farm Radio Network, 40 Dundas Street West, Box 12, Suite 227B, Toronto, Ontario CANADA M5G 2C2

SUGGESTIONS FOR USE

Teachers: For village or classroom lessons, flip charts, plays, stories, songs, etc.

Radio broadcasters, Journalists, Community workers, NGOs: To be adapted for local radio broadcast or as a source of information for magazine and newspaper articles, leaflets, fact sheets, posters, extension visits.

Content: Make compost in small pits in your garden. Put fresh or decomposed kitchen and garden wastes, and manure, directly in these pits. The materials rot and add nutrients to the soil as your garden plants are growing. This is called basket composting in the Philippines.

Length: 726 words; 5 minutes, 15 seconds (approx.)

If you grow vegetables, flowers, fruits, or field crops, you probably know how valuable good compost can be. Compost really improves the soil so that crops will be strong and healthy. Usually when you make compost, you make it in a pile or in a container near the garden. Then when you need it, you bring the well rotted compost to the garden.

Let's think about another method of composting that is done right in the garden. This is a method that will save you time and effort. Instead of making all of your compost in one place, you can do it in a series of holes or small compost pits spread throughout the garden plot. Put your kitchen and garden wastes directly into these small pits before planting the garden. The materials decompose there while your garden plants are growing.

The Mindanao Baptist Rural Life Center in the Philippines uses this method of composting. They call it basket composting and people there say there are many advantages. First, you don't have to wait four or five months before using the waste. You just put the fresh kitchen and other waste directly in the garden. Second, the small pits hold the compost in place right in the garden where the nutrients are needed for the plants. They are like little reservoirs of nutrients and moisture.

Here are the steps to take if you want to try basket composting in your garden. This method of composting will have the best success if you use it in raised garden beds with lots of loose soil.

After the plot is prepared, collect the materials you need to construct the basket compost pits. For each pit you will need:

- 1) Seven bamboo stakes, each 30 centimetres (12 inches) long, and 2 or 3 centimetres (about 1 inch) wide.
- 2) A long strip of flexible bamboo, 12 metres (40 feet) long, and 2 or 3 centimetres (about 1 inch) wide. You could also use a long coconut stem, or strips cut from the trunk of a banana or plantain tree.
- 3) Kitchen and garden wastes, manure, leaves, and other organic materials.

Now start the first pit. It should be located in the centre of one of the raised beds. Drive the seven bamboo stakes into the ground to form a circle 30 centimetres (12 inches) in diameter. Drive each stake half way into the ground.

Weave the long flexible bamboo strip in and out of the stakes, as if you are making a basket. Start weaving at soil level and continue to circle around and up until you reach the top of the stakes. You are moving the strip around and up in a spiral pattern. It's like constructing a small circular fence. If you don't have long strips of bamboo or some similar material, you can use a lot more bamboo stakes and space them very close together to make the fence.

After you have constructed this little circular fence, dig out all the soil inside it to a depth of 12 centimetres (5 inches). You have now completed one basket compost pit. You must now make several more in the same way. They should be spaced in a row about 1/2 metre (1 1/2 feet) apart, from one end of the garden bed to the other. To make compost in each of these pits, (gradually) fill them with fresh kitchen waste and fresh manure if you have it. You can also use well rotted organic material, but it is best to put the most rotten material in the bottom of the hole. After the pit is filled with these things up to ground

level, fill the fenced-in area above the ground with grass, weeds, and leaves (especially leaves from legume plants or trees if you have them). Whenever you pull any weeds out of the garden, just put them in the nearest basket compost pit.

When you plant seeds or seedlings in your bed, plant them 6 to 8 centimetres (2 to 3 inches) away from the compost pits. At the beginning you should water the seeds or seedlings directly, but as the plants get established their roots will grow towards the closest compost pit. You can then just water the compost pit. It has now become a wonderful source of moisture and nutrients for your plants.

After you have harvested your vegetables, the material in the pits should be well decomposed so take it out of the pits and mix it well into the soil in the bed. Make new compost in the pits the next time you plant vegetables in the bed.

Again, here are the advantages of basket composting:

- 1) You can immediately use your kitchen and garden waste in the garden without waiting the usual 4 - 5 months as in other methods of composting.
- 2) The pit holds the compost in place so the nutrients are not lost.
- 3) The pits are like little reservoirs of nutrients and moisture.

- 30 -

NOTES

Basket composting is most successful with the raised bed or double digging method of gardening. This method is described in detail in:

More vegetables from your garden - Package 15, Item 10

Some other DCFRN items which refer to gardening and/or composting are:

Vegetable gardening (Part 1,2,3,4) - Package 7, Items 1,2,3,4

Making your own compost - Package 15, Item 9

Trench-bed gardening for dry lands - Package 9, Item 7

Copies of the above items may be obtained by return mail from DCFRN.

INFORMATION SOURCES

1. Interview with Roy Alimoane, Trainer/Farmer Supervisor, Mindanao Baptist Rural Life Center, Philippines, recorded by Jennifer Pittet.

2. Agroforestry Technology Information Kit, 1989, International Institute of Rural Reconstruction, Silang, Cavite, Philippines. The graphics in this DCFRN item are based on illustrations in the Agroforestry Technology Information Kit.

STEP 1

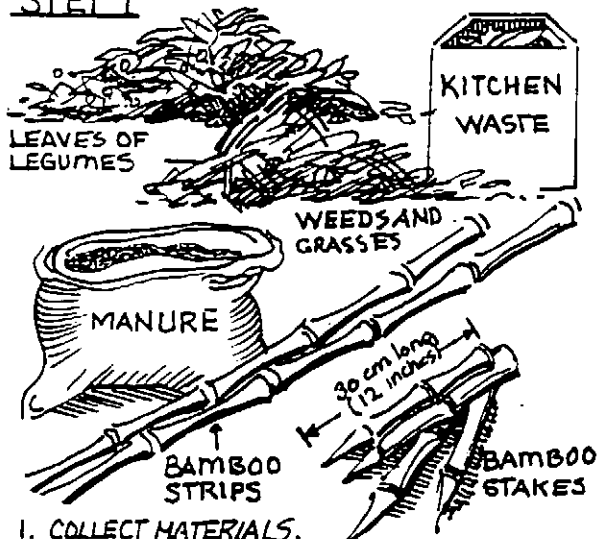

1. COLLECT MATERIALS.

- 7 BAMBOO STAKES 30cm (12 INCHES) LONG AND 2 OR 3 CENTIMETRES (ABOUT 1 INCH) WIDE.
- 1 LONG, FLEXIBLE STRIP OF BAMBOO (OR A COCONUT STEM) 12 METRES (40 FEET) LONG; OR SEVERAL STRIPS WHICH TOGETHER ARE 12 METRES LONG.
- KITCHEN WASTE, MANURE, LEAVES

STEP 2

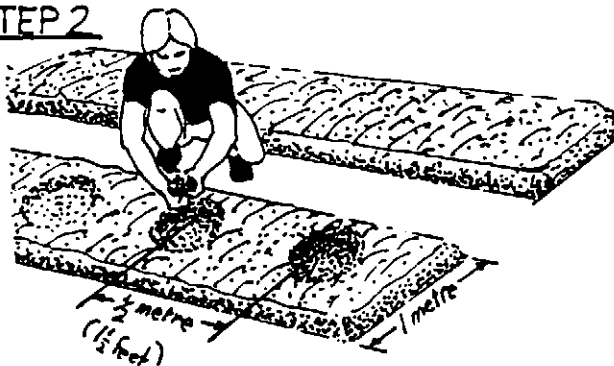

2. PREPARE RAISED GARDEN BEDS.

STEP 3

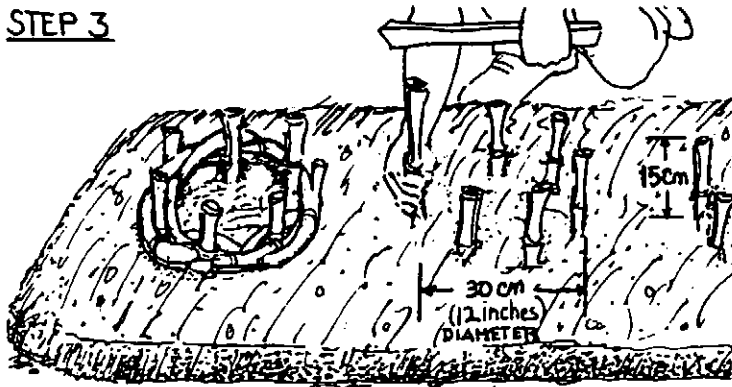

- 3. DRIVE STAKES HALF WAY INTO THE GROUND SO THAT 15 CENTIMETRES (6 INCHES) ARE STILL ABOVE GROUND. FORM A CIRCLE WITH A 30cm. (12 INCH) DIAMETER. WEAVE THE LONG BAMBOO STRIP BETWEEN THE STAKES, AS IF YOU ARE MAKING A BASKET.**

STEP 4

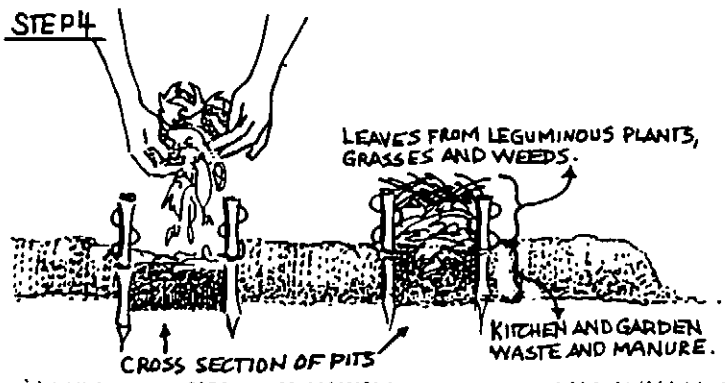

- 4. DIG PIT AND PUT WASTES IN THE PIT.**

STEP 5

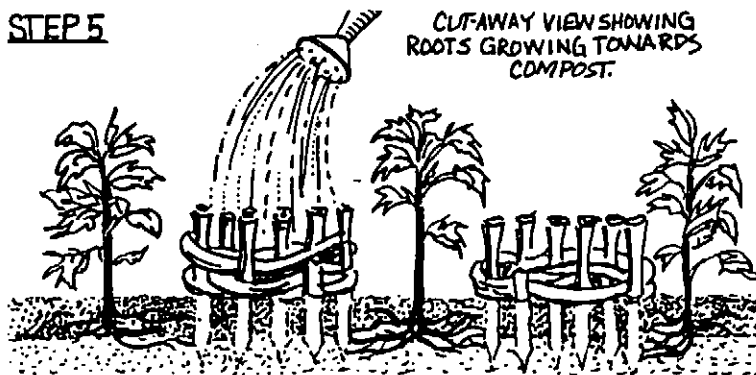

- 5. ONCE THE PLANTS ARE ESTABLISHED, JUST WATER THE COMPOST PIT.**

STEP 6

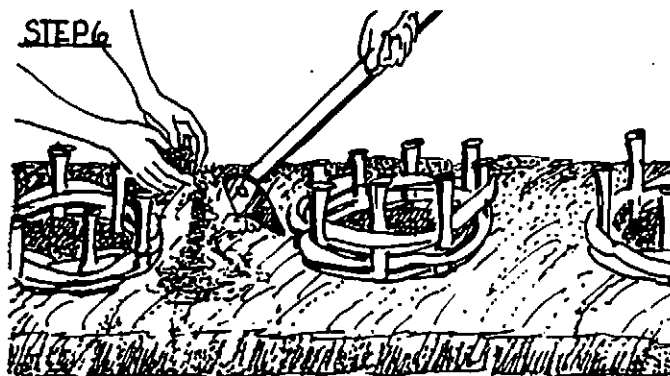

- 6. AFTER THE HARVEST, TAKE THE COMPOST OUT OF THE PITS AND MIX IT WITH THE SOIL.**

A Burning Issue

SOURCES

Adapted from *The No Waste Anthology: A Teacher's Guide to Environmental Activities K-12* produced by California Department of Toxic Substances Control, Public Education Unit. California Dept. of Toxic Substance Control, P.O.Box 806, Sacramento, CA 95812-0806, U.S.A. and Activity 8 (K-6) in *Let's Reduce and Recycle: Curriculum for Solid Waste Awareness, Lesson Plans for Grades K-6 and 7-12* produced by U.S. Environmental Protection Agency 1980, revised 1990. U.S. Environmental Protection Agency, 401 M Street, S.W. Washington, D.C. 20460, USA.

If reproduced for non-profit, educational purposes in low-income countries, please credit original sources.

SUGGESTIONS FOR USE

Teachers: To introduce students aged 6 years and older to the principles of waste combustion.

Background notes:

For background notes, read "Wasting Our Resources", page 1.

Introduction for class:

Have you ever sat in front of a fire and watched a log burn down to ashes? Those ashes take up less space than the log did. For this reason, people began burning waste and disposing of the ashes in landfills or dumps.

Experiment:

Which items burn and which don't? Which things melt? What enters the air when materials are burned? When do these burned particles become air pollution? Can the burned material be recycled?

Answers to these questions may be discovered by observing what happens to waste during incineration.

You will need:

- * a small cardboard box (for example, 6ins. x 6 ins. x 6 ins. or 6 cm. x 6 cm. x 6 cm.)
- * small pieces of waste food (e.g. apple core, egg shell), aluminium foil plastic wrap, glass and newspaper
- * a metal screen large enough to fit on top of the can
- * a one-gallon tin can with several nail holes in the side near the bottom.

1. Take the measurements of the cardboard box, and then fill it with the waste. Loosely place the waste from the box into the can.
2. in a safe place outside and under adult supervision, light a match to the contents, and then put the screen on top of the can immediately. Observe what happens. What burns, what melts? What comes out of the can while the materials burn? Where does it go? Is everything that comes out visible?
3. After the fire is out, and the ashes are cold, dump the ashes into the box. Compare the amount of space taken up by the ashes to the space taken up by the wastes in their former state.

(The paper burns easily; the food will char but not really burn; the plastic will catch on fire, and drip down into the can, giving off fumes as a result of its petroleum base, and leave a sticky residue. The metals will not burn at all.)

ANSWERS TO WASTE AWAY CROSSWORD (on page 34)

Across - 3. photodegradable; 4. toxic; 6. biodegradable; 8. recycle; 11. groundwater; 12. reduce; 15. nonrenewable; 16. hazardous.

Down - 1. sanitary landfill; 2. decomposition; 5. litter; 7. resources; 9. incinerator; 10. leachate; 13. trash; 14. compost.

Compare what happens to waste in a dump and in a landfill

SOURCE

Adapted from Activity 7 (K-6) and Activities 6 and 7 (7-12) in *Let's Reduce and Recycle: Curriculum for Solid Waste Awareness, Lesson Plans for Grades K-6 and 7-12* produced by U.S. Environmental Protection Agency 1980, revised 1990. The activity may be reproduced for non-profit, educational purposes in low-income countries provided credit is given to the original source. For further information, contact U.S. Environmental Protection Agency, 401 M Street, S.W. Washington, D.C. 20460, USA.

SUGGESTIONS FOR USE

Teachers: A practical activity for elementary and lower secondary school students. The activity may form part of project work on waste.

Background notes: See *Wasting Our Natural Resources*, page 1.

Have students work in small groups to construct a mini-dump and a mini-landfill.

To make the mini-dump, the students should cut off the top of a large plastic milk or water bottle and fill it with moist soil. On top of the soil place small pieces of the following objects: a paper clip, newspaper, a piece of plastic, a piece of foil paper, food scraps (apple core, potato peelings etc.). Sprinkle periodically with water and leave uncovered.

To make a mini-landfill, have students cut three-quarters of the way around the top of a large plastic milk or water bottle. Have them place a layer of soil on the bottom, then alternate layers of soil and garbage, leaving a layer of soil at the top. The garbage should include a variety of organic and inorganic items, as described above. Sprinkle with water to simulate rain. Seal openings with masking tape, and cover with the lid. Open the lid to air and water the landfill approximately every other day.

Have each group of students list all of the items they have placed in the mini-dump and mini-landfill, and keep separate charts monitoring the changes in both over a period of several weeks. At the end of the observation period, discuss with the students the differences between what happened in the dump and in the landfill.

In the dump, over a period of time, you can expect the food to rot and smell slightly. The newspaper will also begin to break down. Paper wrappers will decompose. The paper clip will gradually rust, but nothing will happen to the plastic or aluminium foil. Very little decomposition should take place in the landfill, and it should not smell. Tell students that the liquid waste that comes from a dump or landfill is called leachate, and it could seep through the ground and contaminate ground water. A sanitary landfill controls leachate that is produced.

Here are some questions to ask the students:

1. Can you think of any problems that might result from disposing of garbage in an open dump? *(Answers might include odours; attract rats or other pests; disease; ugly; run out of space to put more garbage; liquids and metals could leak to the ground-water supply; gases produced by decomposing materials pollute the air, and may even set off fires and explosions if not controlled; dumps built in fragile environments such as wetlands, earthquake zones or floodplains, may pose a threat to ecosystems.)*
2. What problems associated with open dumps have been solved by sanitary landfills? *(Answers might include landfills do not smell; do not attract rats or other pests; they collect most if not all leachate; they can collect gas buildup from decomposition.)*
3. What problems still remain with landfills? *(Answers might include little decomposition takes place in landfills because oxygen, which bacteria and most decomposers need, does not penetrate the compacted layers of the landfill; run out of space to put garbage.)*

Waste Away Crossword Puzzle

SOURCE

The crossword puzzle below is reprinted from *Waste Away: Information and Activities for Investigating Trash Problems and Solutions for Upper Elementary and Junior High Students*. *Waste Away*, a 120-page publication was produced and published in 1989 by Vermont Institute of Natural Science, Woodstock, Vermont 05091, U.S.A. It costs U.S.\$18.95 plus shipping and handling. The activity may be reproduced for non-profit, educational purposes in low-income countries provided credit is given to Waste Away/Vermont Institute of Natural Science.

SUGGESTIONS FOR USE

Teachers: Use as an individual student activity to reinforce understanding of waste concepts and terminology.

Children's newspaper supplement/magazine editors: Include in an issue on waste.

(Note: Younger students may use a word list - made up of the crossword answers - to help them complete the crossword.)

Answers: on page 32

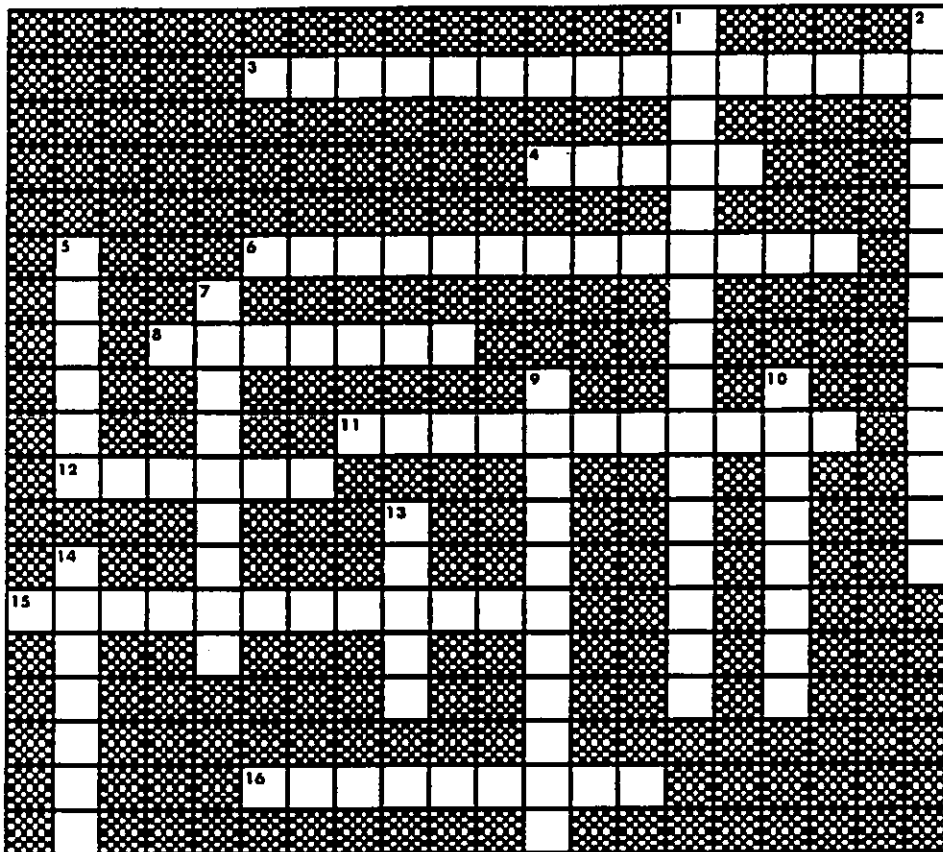

© 1989 Vermont Institute of Natural Science, Woodstock, VT, Waste Away Program

ACROSS

3. Capable of being broken down by ultraviolet light
4. Poisonous
6. Capable of being broken down into simple compounds by microorganisms
8. To collect and reprocess manufactured materials for reuse either in the same form or as part of a different product
11. Water found below the surface of the earth
12. To make less of something
15. Limited in amount, cannot be replenished
16. Dangerous, harmful

DOWN

1. A specially-engineered site for disposing of trash on land to protect public health
2. The breakdown of organic material by bacteria and fungus
5. Waste material discarded in an inappropriate place
7. Raw materials used to make products
9. An _____ reduces waste volume by burning
10. A liquid containing bacteria and other poisonous materials which often drains out of landfills
13. Another word for solid waste
14. Decomposed organic waste which is used to fertilize soil

Issue 93
Waste part 3: Recycling

CONTENTS

	Page(s)
Location map	ii
How to use this pack	iii
Tyres and tins -- recycling in the Third World	Article 1-3
What's in a cycle	Class activity 3-4
Trashing lives	Article 5
Recycling has many benefits	Information 6
Two toy cars	Activity 7
Urban waste: a valuable resource	Activity suggestions 8-12
How glass, tin cans, paper and plastic are recycled	Class activity 13
Recycled products quiz	Puzzle 14
How to recycle paper from waste	Class/group activity 15-17
A newspaper bundler	Activity 17
New uses for old tyres and inner tubes	Radio transcript 18-20
Work from waste: recycling wastes to create employment	Resources 21-22
Starting a vegetable waste recycling business	Fiction 23-26
Desert food from petroleum waste	Article 26-27
Recycled plastic sheets	Article 27
Make yourself a plastic raincoat	Activity 28
Two young Brazilians making a difference	Article 28-30
Muscle-saving can crusher	Activity 30

LOCATION MAP

The map below shows the location of countries mentioned in OUTREACH issue no. 93:

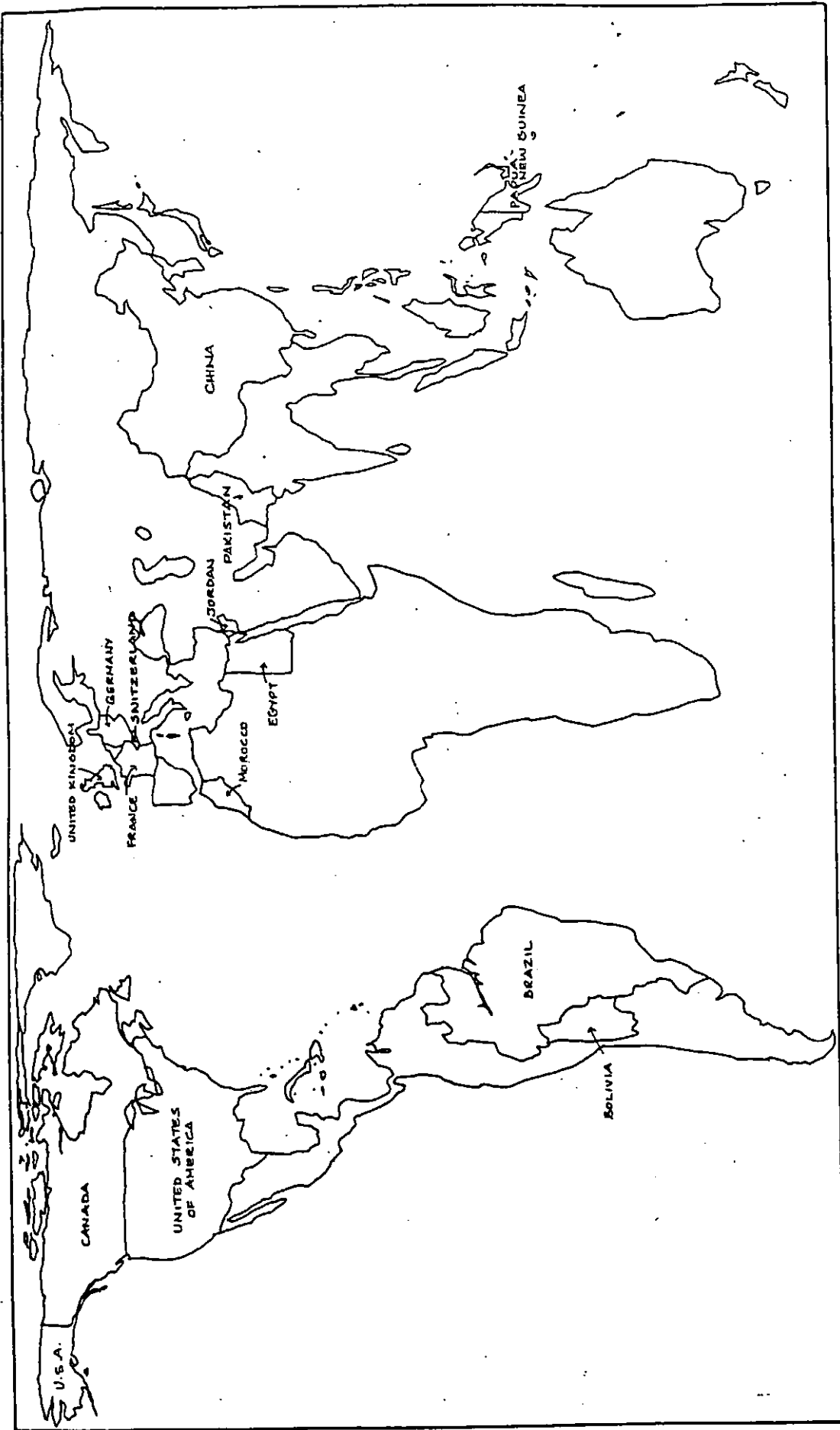

USEFUL CONVERSIONS FACTORS

linear measurements: 1 in. = 2.54 cm. 1 yd. (36 ins) = 0.91 m.

square measurements: 1 acre = 0.42 Ha. (1 km.² = 100 Ha.)

weights: 1 long ton (2,240 lb) = 1.02 metric tonnes

1 mile (1 760 yd) = 1.61 km.

1 sq. mile (640 acres) = 259 Ha.

1 short ton (2,000 lb) = 0.91 metric tonnes (1 metric tonne = 1,000 kg.)

How to use this OUTREACH pack

Issue 93: Waste part 3 - recycling

This pack is the third in a series of five OUTREACH packs that explore waste and recycling. It is devoted to one of the management practices in the waste management hierarchy mentioned above, and that is recycling which, to many people in the Third World, offers a means of earning a living. The issue looks at a variety of materials and products that are suitable for recycling, and offers guidance and suggestions for those interested in starting a waste recycling business.

Other packs in the waste and recycling series include three more general packs and one Learning-By-Doing leaflet pack:

91: Global problems, local solutions;

92: Conserving natural resources;

94: What to do with hazardous waste;

95: Learning-By-Doing leaflets on waste and recycling

At the beginning of each segment there are suggestions as to how the material might be used by multipliers. Here are some general suggestions:

- * **A newspaper editor** might adopt the articles on pages 26-27 as 'fillers' for the newspaper's science-in-the-news section.
- * **Youth leaders** might use the article on pages 28-30 in a group discussion aimed at encouraging students to get involved in local environmental action.
- * **Teachers** might use 'Trashing Lives' (page 5) as a comprehension exercise, or as part of a class discussion on health risks to children.
- * **Journalists** working on a children's environment and health magazine or newspaper supplement could adopt the "recycled products quiz" (page 14) and adapt the "two toy cars" activity (page 7).
- * **Radio journalists** might simply make use of the recycling transcript (pages 18-20) or adapt different parts of the pack to develop programmes on starting a recycling business (The fiction on pages 23-26 could be used to introduce the idea; local recycling entrepreneurs could be interviewed to show how they got started, and the programme could conclude with practical advice for the would-be recycler.) The latter idea might also be taken up by **journalists in the print media** as well.
- * **Community workers**, trying to start up recycling projects in the local community, might use the activity suggestions in 'Urban waste: a valuable resource' (pages 8-12) to form the basis of a workshop on recycling. Practical activities could be incorporated into the workshop, such as making a can crusher (page 30).

Tyres and Tins -- Recycling in the Third World by Jürgen Grothues*

SOURCE

Reprinted from *GATE* No.3/89 (October 1989) "Recycling". The article may be reproduced for non-profit, educational purposes in developing countries. If reproduced, please give credit to the publishers, Deutsches Zentrum für Entwicklungstechnologien. For further information, please contact Deutsches Zentrum für Entwicklungstechnologien, Dag-Hammarskjöld-Weg 1, D-6236 Eschborn 1, Germany.

SUGGESTIONS FOR USE

Teachers: As an introduction to project work on recycling.

Radio broadcasters, Journalists: To increase awareness on recycling issues.

In the industrialized countries, at least some "waste" or "throw-away" materials are re-used in industrial recycling processes; the material is recovered to make more of the original products; that is, new bottles are made from old glass, new paper is made from old. In the developing countries, however, waste materials are re-used in a completely different way. Without going through the process of recovering the original raw materials, these materials are re-used in completely new forms and functions. In particular, old tyres and tin cans are turned into all sorts of useful objects by artisans specializing in this work. This article, based on field research in Pakistan and Morocco, illustrates some aspects of this development.

The history of this kind of recycling can be traced back to the early days of contact between cultures. With the first expeditions and colonization, industrially produced European consumer goods found their way overseas in the form of supplies. Expedition reports and diaries of colonial officials document the fact that Europeans themselves often re-used empty bottles and other receptacles which were in short supply. They converted these containers into utility objects, or used them as barter currency for trade with the native population. Such objects were never regarded as "waste" or "throw-away" articles, as was the case in Europe. The earliest reports date back well into the last century.

Today, industrially produced consumer goods are found all over the world. The major industrial concerns have also "discovered" the developing countries as important markets. Canned beverages and foods, or modern means of transport can be found in even the most remote regions. And industrial production of consumer goods is now playing an increasingly important role in the developing countries themselves. As a result of this development there has also been a major increase in the amount of re-usable waste materials generated.

This situation, coupled with the poverty and shortages prevailing in many parts of the Third World, has led to the development of a very complex, independent sector of the economy which specializes in using this "waste".

Waste collectors

Thousands of waste collectors roam the residential areas of the towns and cities with hand or donkey carts, buying cans, bottles and other items, or they comb the rubbish dumps on the outskirts of the cities for re-usable articles.

The waste collectors in turn supply specialized artisans who convert these raw materials into utility objects. Some of the products that result from the processing of tin cans and car tyres are particularly impressive.

Recycling artisans

The fact that these new craft trades have come into being is an impressive example of the creativeness and self-help potential that exists in the developing countries. Without any government aid or other outside assistance, millions of people all over the world have created a livelihood for themselves in this sector of economy.

The recycling artisans have meanwhile integrated themselves perfect-

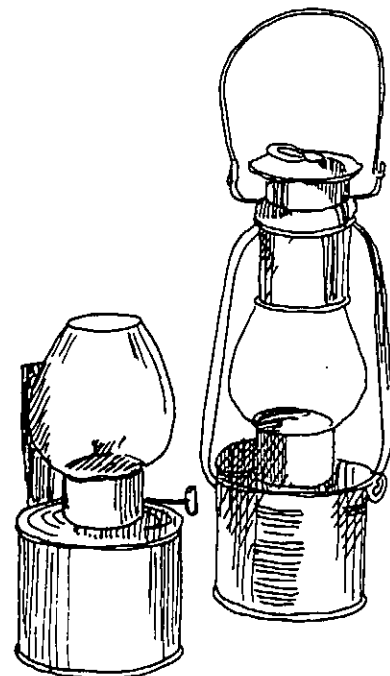

Lamps (from Pakistan) and a water bag (from Morocco) made out of waste material

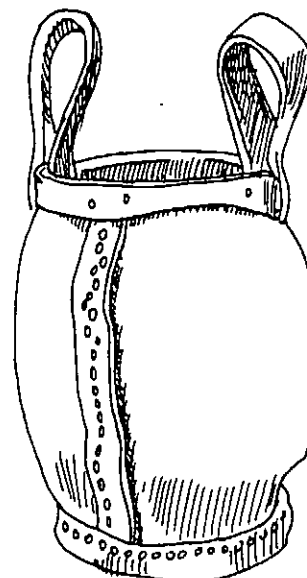

* Dr. Jürgen Grothues studied ethnology and sociology in Münster. He is now a freelance ethnologist specializing in economic ethnology and cultural change.

ly into the traditional market and bazaar structures. Like the traditional craft trades, the recycling specialists have their own areas in the bazaar, segregated according to materials. Whole streets are given over to recycling businesses. In addition, many small mobile workshops have been set up on the roadside. The workshops are not only production facilities, but also sales outlets where the artisans sell direct to consumers. Their potential clientele includes not only the poorest sectors of the population, but also blue- and white-collar workers with low but nevertheless regular incomes. For them, there is no alternative to these articles, which are by far the cheapest of their kind.

The best conditions for recycling artisans are still to be found in the big cities, where there is not only a large number of potential consumers, but also a constant and adequate supply of materials to process.

Meanwhile, however, the recycling industry has expanded far beyond the urban areas. Many and diverse forms of recycling can also be found in small towns and rural areas. Wherever there is only an inadequate supply of re-usable materials, finished recycling products from the towns have found their way in. Thus a lack of recycled objects can now be considered characteristic of the last strongholds of unspoiled, traditional material culture.

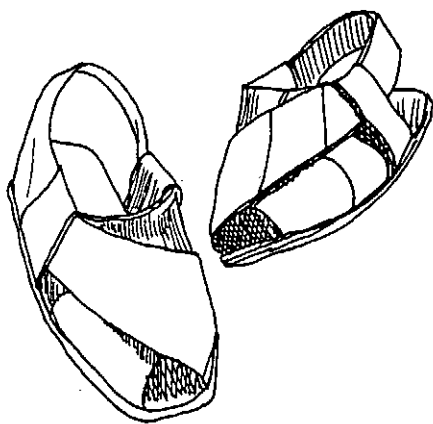

Sandals made from old tyres

Organization of work and technology

In the organization of their work, artisans, in these new craft trades have been able to make use of traditional forms. Like the old-established craftsmen they too usually work together, two or three to a workshop. Many of the businesses are family enterprises which have been in existence for two or three generations, and where the craft skills are handed down from father to son.

A key factor which encouraged the development of the new crafts was the nature of the material. Both the tinplate of tin cans and the rubber used in tyres are relatively easy to reprocess. Only a relatively small number of tools are needed to make the products. Tin and leather shears, hammers and tongs, the basic equipment of a recycling workshop, are cheap and, in addition, easy to come by in the developing countries themselves. This equipment is complemented by a large number of improved aids: a length of railway track is used as an anvil and workbench, pipes and T-irons are used for shaping curves or producing folded edges. Many artisans have developed their own solutions to technical problems.

Hence businesses can be set up with very little capital outlay, so that even members of low-income groups have managed to become established and earn a living in this sector. Recycling has thus developed into a major survival strategy for marginal groups, most of whom have no prospect of benefiting from government assistance or job-creation schemes. And so it is a model example of successful self-help in practice – without any “help towards self-help” from outside.

As regards the technology, too, the artisans have been able to draw on traditional methods. Tyre recyclers in particular can adopt methods similar to those used in leather processing, because of the nature of the material. The essential techniques in rubber processing are the same as for leather, i.e. sewing and nailing to join the material. Shoemakers have also integrated the new material into their trade, using tyre rubber to make soles.

The simple technologies of the recycling trade are applied with great skill and ingenuity. Articles are produced with carefully considered, optimum utilization of the material available. What kind of product will ensure optimum use of the material depends on the condition of the can or tyre. The handyman's attitude (“I can always find a use for that”), improvisation with the materials available, and a permanent dialogue with the material are characteristic of the recycling trade.

The products

The artisans' ingenuity and creativeness also find expression in the diversity of the products. One impressive and symbolic example of this creativeness is an oil lamp whose fuel reservoir is a burnt-out light bulb. Artisans from Sri Lanka, Tanzania, Ghana and Burma discovered this use for light bulbs – the symbol of human inventiveness – quite independently of one another.

In Pakistan alone, there are well over 100 different recycling products for sale on the markets. They satisfy basic needs of daily life and are to be found in all areas of material culture. They include everything from structural elements for buildings to children's toys, from musical instruments to household utensils of every conceivable kind. The range of household goods includes storage receptacles, sieves, cook-pots, lamps, suitcases and much more besides. Shoes, bags and water bags are made from old tyres. Theoretically it would be possible to put together a complete “recycling household” from all these products.

Where previously calabashes or animal skins were used to draw water, tin cans or water bags made from old tyres are now in use in many places. On many markets tin cans are used as measures for goods. They are accepted as an accurate unit of measurement with little scope for manipulation. In many places this has led to the introduction of new units for weights and measures – one of the numerous “side-effects” of recycling.

Effects of recycling

As with every kind of cultural change, the development of the re-

ycling trade has had a variety of effects.

The recycled products have supplanted many traditional objects and implements. Recycling artisans compete with traditional craft trades such as pottery and leatherworking. In the small town of Hala, for example, a traditional crafts centre in southern Pakistan, the new compe-

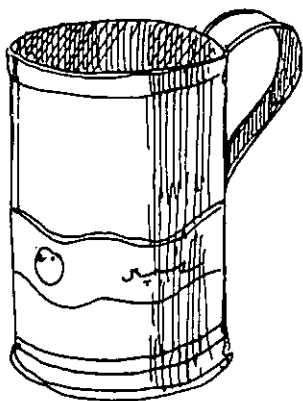

A measuring beaker made from an old tin can

tion has caused a drop of some 50 per cent in the number of potters. The recycled products have proved to be cheaper and to last longer than the potters' earthenware.

Other artisans with traditional occupations have integrated the new materials into their trades. Many smiths, for example, have switched to using scrap iron. As a result of this development the ability to mine and smelt iron ore is in many places now a forgotten skill.

Since the materials processed are the same all over the world, the end-products are often also very similar. So recycling products from different places are practically indistinguishable. Only in a few, exceptional cases are there any stylistic ele-

ments which are clearly typical of a particular culture. The development of these trades is thus also leading to greater uniformity of material cultures.

This form of recycling is also clearly having an ecologic impact. With their ingenuity and industriousness, the artisans and their suppliers, the waste collectors, are helping to incorporate valuable materials in new production processes while at the same time easing the burden of «official» waste disposal services.

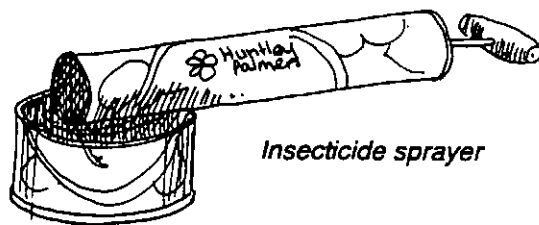

Insecticide sprayer

CLASS ACTIVITY

What's in a Cycle?

SOURCE

Adapted from: *A-Way with Waste* (1985), curriculum material produced by Washington State Department of Ecology, USA. The activity may be reprinted for non-profit, educational purposes in low-income countries. If reproduced, please credit *A-Way With Waste*, Washington State Department of Ecology, 300 Desmond Drive SE, P.O.Box 47600, Olympia, WA 98504-7600, U.S.A.

This curriculum is written and organised to present integrated waste management concepts affecting land, air and water in the ecosystem. The activities for students aged 5 to 18 years, are designed to promote awareness, attitudes and actions to solve waste management problems at home, in school and in the community.

SUGGESTIONS FOR USE

Teachers: As an introductory lesson on recycling, in a social studies or science class for 7 to 11 year olds. Through this activity, students will be able to identify, compare, and evaluate how cycles are important.

PROCEDURE

1. Explain to students that cycles are an important aspect of life on earth. A cycle may go through many phases, yet it always arrives back at the point of origin. Thus, cycles ensure that life can go through many changes, and yet maintain stability. Write on the board and examine the following cycle of life:

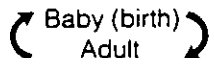

We could also include in this cycle the many stages from birth to death to new birth. However, in simplest terms, this cycle shows how life is able to change, through new birth, and yet remain stable. The new life is patterned after the old.

2. Explain to students that there are endless cycles around us. Ask: Can you think of any?

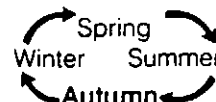

3. Cycles are also important to our everyday lives. Can you draw a cycle of your typical Tuesday at school? A cycle of your typical week? What would happen if every day or every week were completely different, that is without repeating pattern? (You couldn't build on the past, wouldn't be able to accomplish as much, wouldn't be able to cope with so much change.)

4. Once any step in a cycle is disrupted, the cycle stops or is changed. What is wrong with this process?



(This process cannot go on forever - oil is not a renewable resource.)

5. Cycles ensure survival. Compare these two cycles:

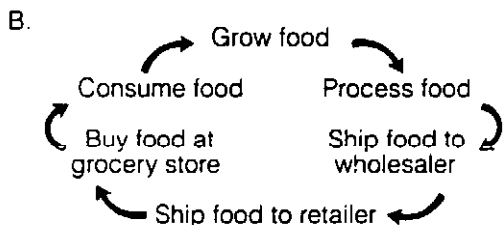

Which of these cycles of food consumption represents our lifestyle? Which cycle can be more easily disrupted? (B) Why? (Because it involves more steps and could be interrupted by unforeseen outside forces disrupting the continuum of the cycle.) Which cycle is more dependent on nonrenewable natural resources? (B)

Ask: What is a nonrenewable resource? Can anyone give an example of a nonrenewable resource? (A natural resource is nonrenewable because of the great length of time needed for its formation. Petroleum is a good example of a

nonrenewable natural resource.) What are some other nonrenewable natural resources you can think of? List on the board.

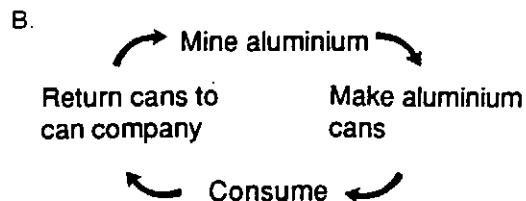
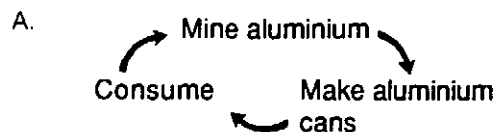

Which is a cycle? What part of "B" is a true cycle while "A" is not? Draw in the arrows. What is the last stage in "A"? (lost in the landfill.)

What is the true cycle in "B" called? (recycling) What is the advantage in recycling? (saves non-renewable resources, conserves energy)

6. Using another nonrenewable natural resource from the list on the board, draw another cycle that is made possible by recycling.

DISCUSSION/TEST QUESTIONS

- What is meant by the term "nonrenewable natural resource"?
- List three nonrenewable natural resources.
- How does recycling conserve natural resources?
- List 2 nonrenewable natural resources you conserve by recycling.

Trashing Lives

SOURCE

The following article is adapted from "Trashing Lives" by Susanna Rance in *The New Internationalist* (No.203 January 1990): Shopping for the Planet - the Green Consumer.

If reproduced, please credit original source. For further information, write to *The New Internationalist*, 55 Rectory Road, Oxford OX4 1BW United Kingdom

SUGGESTIONS FOR USE:

Teachers: As a reading and comprehension exercise for students while increasing their awareness of reliance on waste recycling for survival in Third World cities.

Radio broadcasters: As a descriptive piece to introduce a programme on urban recycling.

Children's newspaper supplement/magazine writers: As basis for a comic strip about waste scavengers.

Little Amaru looks down at the street, and kicks a can with his red gumboot.

"We're near home, aren't we?" he concludes.

"Yes love, how do you know?" his dad replies.

"Because there's rubbish. That's life isn't it, Papi?"

From the market street, the rubbish tip is invisible by day. Only a layer of dust remains on the stretch of pavement where vendors sit selling fruits, vegetables and spicy food. Passer-bys pause there to admire the spectacular view over shanty-town rooftops, across the crater-like basin of the city to the Andean ranges on the other side. Above them towers the snow-capped Mount Illimani, symbol and guardian of La Paz.

As night falls, the scene changes. The encroaching dark is a signal for people to emerge from nearby houses with boxes and bins to dump their trash. At first a discreet pile, the mound grows steadily until it covers the pavement almost knee-deep for 20 yards.

Then, the scavengers move in. Flames flicker as they set light to the rubbish -- not to reduce it to ashes, but to see what is worth collecting. Poking around with sticks, they hold up promising finds to examine them, while eerie shadows move between the fires on the black tip.

Among the regulars at the dump is a pack of stray dogs, rooting around for bones and scraps.

They compete with neighbours gleaning leftovers for their rabbits, sheep and pigs. Another group combs the refuse for tins, bottles and plastic containers to be sold on junk stalls.

Then, come the children for whom the nightly forage produces not only improvised toys, but anything which can conceivably be sold to raise a bit of cash. Some are street kids who rely on their ingenuity to keep alive. They take their night's work seriously and do the rounds of local houses, carting bundles of trash to the tip for a few pennies, and getting first pick of each load.

David, aged nine, empties the bin of one house, to pick out the salvageable items before he crams the rest into a sack to take to the dump.

"I can sell these in the Sunday market for 50 pence," he says, carefully setting aside a bundle of magazines. A bottomless garbage bin, a plastic oil container and a private selection of empty bottles have already been added to his private junk heap, waiting to be collected one day when he has time.

To some the rubbish tip is an eyesore. To others it means a chance to recycle whatever may still have a shred of use. Nothing is wasted, and only the dregs are left, charred and thoroughly sifted, by the time the municipal refuse truck comes through at dawn the next day.

Questions:

1. Who visited the dump at night? (dumpers, stray dogs, scavengers including children)
2. Why did people visit the dump? (to dump waste, to collect usable materials)
3. What kinds of things were salvaged from the dump? To what use could you have put these things? (food scraps for animals, bottles, containers for reselling, toys)
4. What are the dangers that face the night visitors? (fires, stray dog bites, hazardous waste)
5. What do you think Amaru is feeling when he says, "That's life isn't it?"
6. Describe a day and night in the life of David.
7. What do you think should be done to improve the lives of the children mentioned in the article?

Recycling has many benefits

SOURCE

Reprinted from *Help to Save the World: Programme Resource Material on Conservation* published by the World Scout Bureau in close cooperation with WWF - World Wide Fund for Nature (1990). Requests to reprint this material should be addressed to the World Scout Bureau, P.O. Box 241, 1211 Geneva 4, SWITZERLAND.

SUGGESTIONS FOR USE

Children's magazine/newspaper supplement editors: As material for illustrations.
NGOs, Journalists, Community workers: As source material for pamphlets and posters promoting recycling.

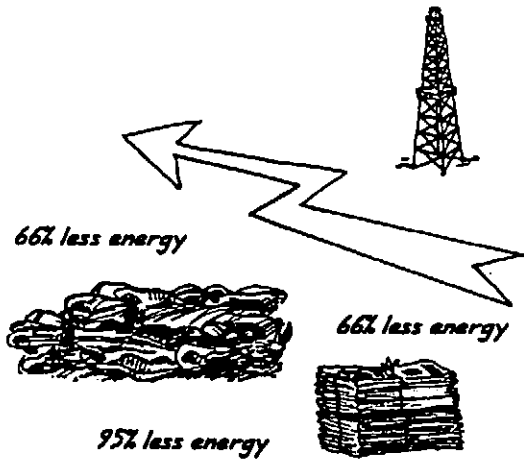

RECYCLING SAVES ENERGY

- It takes
- 66% less energy to recycle paper than to make it from pulp
 - 95% less energy to make aluminium from scrap than from ore
 - 66% less energy to make steel from scrap than from ore.

The amount of electricity it takes to manufacture one aluminium can would let a person shave daily with an electric razor for three years.

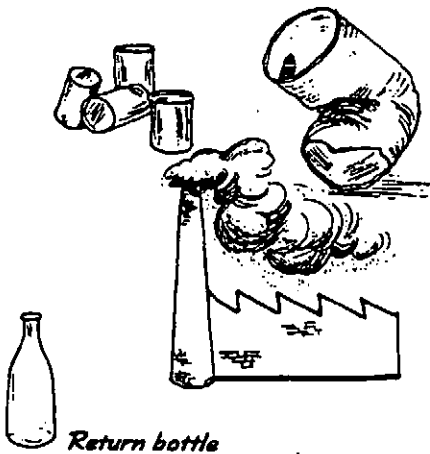

RECYCLING SAVES RESOURCES AND CAUSES LESS POLLUTION

A return bottle is used on an average 30 times.
 Recycled batteries mean that nature is saved from harmful substances like acid, cadmium, nickel and mercury.



RECYCLING SAVES VALUABLE FORESTS

One ton of recycled paper means 16 saved trees plus a lot of saved water and energy.

To print one Sunday issue of America's biggest newspaper takes 48 hectares of forest. This equals an area of 96 football grounds.

RECYCLING CAN BE A SOURCE OF INCOME

- Collect and sell aluminium cans.



Two Toy Cars

SOURCE

Reprinted from UNICEF Development Education Kit No.10: *Precious Junk: The Ingenious Use of Scrap in the Sahel* (1980). If reproduced, please credit UNICEF. For further information, contact UNICEF D.I.P.A., 3 United Nations Plaza, New York, NY 10017, U.S.A.

SUGGESTIONS FOR USE

Teachers: As an exercise on recycling.
Children's magazine/newspaper supplement editors: To adapt for inclusion in an issue on waste and recycling.

Here is a picture of two boys playing with toy cars. Colour the picture, and then answer the questions below.

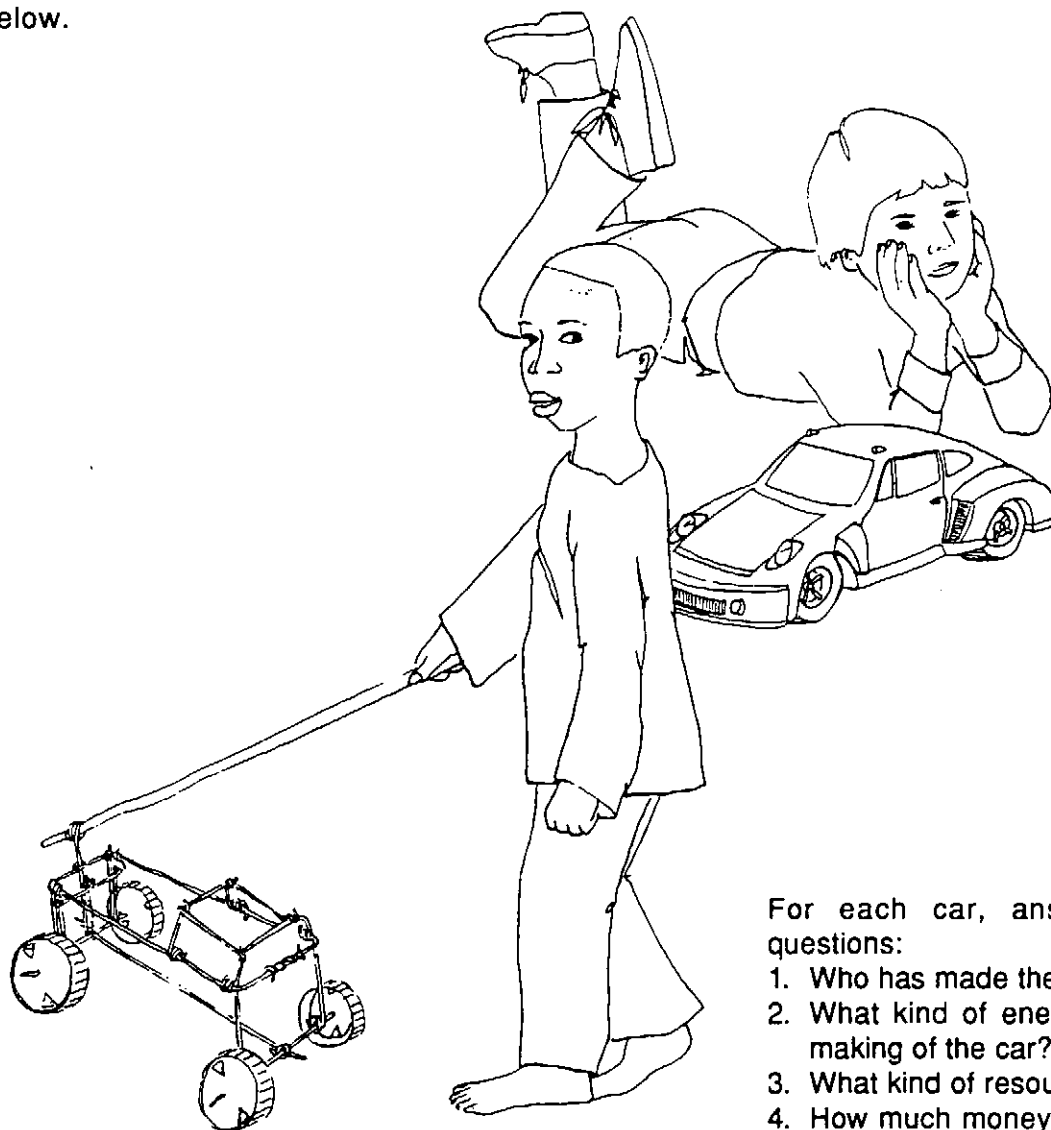

For each car, answer the following questions:

1. Who has made the car?
2. What kind of energy was used in the making of the car?
3. What kind of resources were used?
4. How much money do you think the car cost?
5. What happens if the toy car breaks down?
6. Which car do you think is more fun?

Discuss with your friends the good and bad things about both kinds of cars.

Urban Waste: A Valuable Resource

SOURCE

The following article is by Yona Friedman, Coordinator, Communication Centre of Scientific Knowledge for Self-Reliance, and is reprinted from a series on Immediate Education for Survival which appeared in *Invention Intelligence*, New Delhi in March 1985. The series was "an elementary course of practical science" to enable lay people, with little or no education, to come to terms with problems of survival through self-help, and to be able build up an autonomous capacity for change and innovation.

This article may be copied or adapted to meet local needs provided that the material is distributed free or at cost and not in any commercial context, and provided that, when printed, the original source is acknowledged. For further information, write to: Communication Centre of Scientific Knowledge for Self-Reliance, 33BD Garibaldi, 75015 Paris, FRANCE.

SUGGESTIONS FOR USE

Teachers, Community workers: As an introduction to practical projects on waste, and as a source of ideas for recycling activities.

Journalists, Radio broadcasters: As the basis of an article or script to increase awareness of recycling possibilities.

Urban waste could prove to be a valuable resource for extracting a variety of important materials useful for constructing houses, making household goods, producing compost, etc.

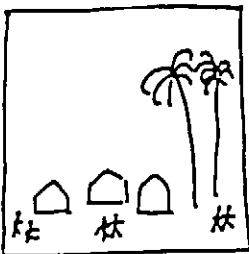

People living in the countryside can find many resources – space, materials, and so on -- to which they have access without spending extra money.

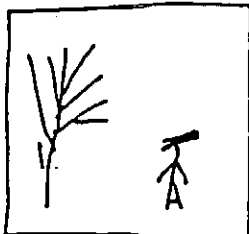

They have free access to trees,

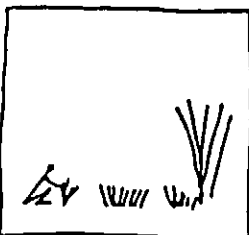

and other plants (for example, bamboo),

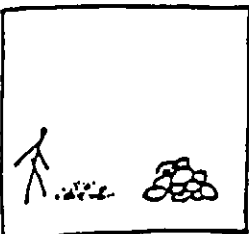

clay and stones,

which they can use as building materials, for instance.

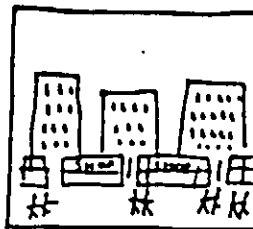

People living in the cities, however, can find such materials

only at a price.

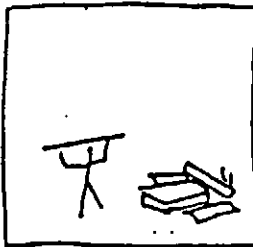

But in cities, too, there are materials which don't cost money:



these are the waste products and materials

thrown away by the rich and the various industries.

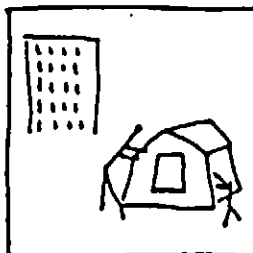

This waste does not need to be purchased,

and can be made use of in a variety of ways.

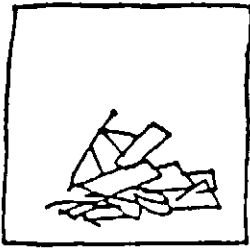

Materials which are easy to find in urban waste are

paper and cardboard,

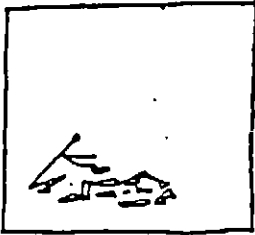

wood-chips,

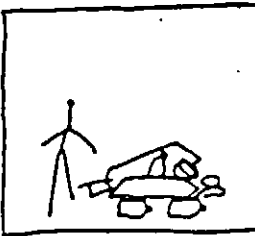

plastic products, metal sheets, glass bottles,

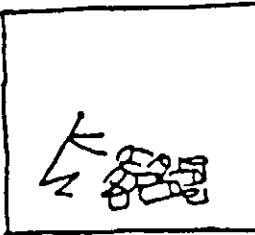

empty conserve tins,

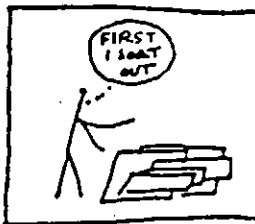

Many things can be made out of these materials.

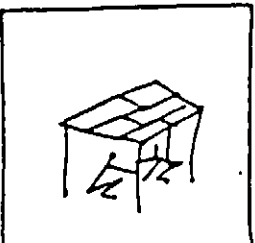

For example, paper and cardboard can be used directly to make various objects out of them.

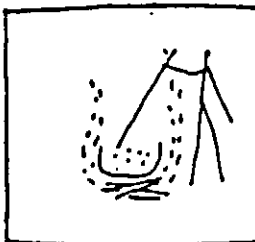

Paper can also be used as raw material for papier mache,

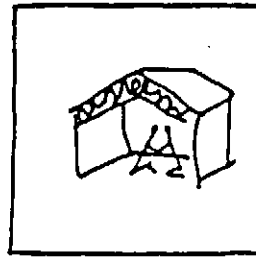

or it can be used as a filler (for insulation against heat, for example).

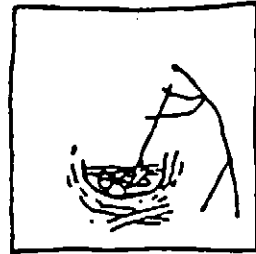

To make papier mache,

you have to boil scrap paper in water, with some glue,

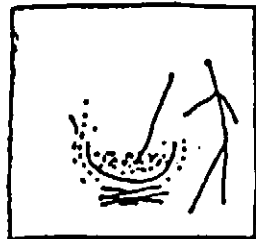

until it becomes a thick paste.

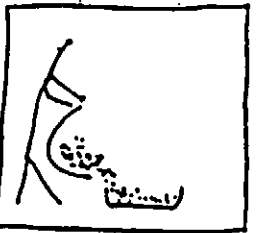

This paste can be shaped and moulded the way you want.

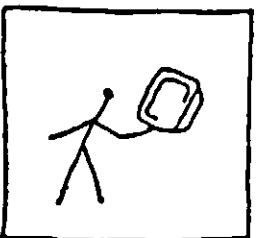

After cooling and drying, the paste becomes hard and the moulded object retains its shape.

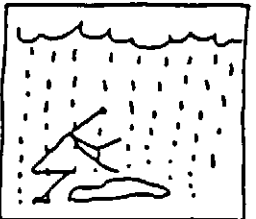

Papier mache is vulnerable to water:

on getting wet, it softens again.

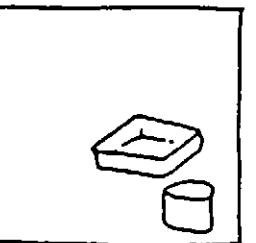

Therefore, it is suitable for applications where it does not get wet:

for example, as containers, cases or drawers.

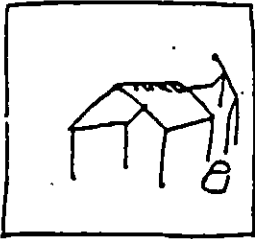

You can protect papier mache against humidity with water repelling materials --

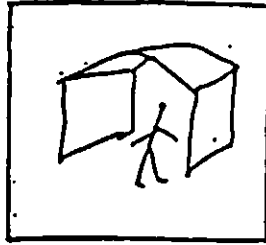

walls, partitions, roofs (but be sure to protect the material against humidity),

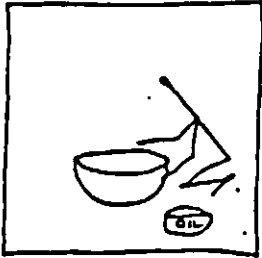

like grease, oil and paint.

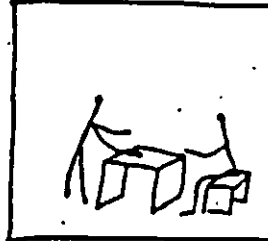

tables, chests, other furniture,

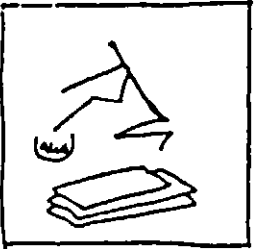

You can make stratified cardboard yourself

by gluing together layers of paper, papier mache or ordinary cardboard.

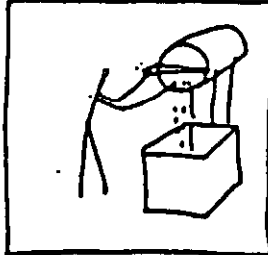

containers,

and many other things of daily use.

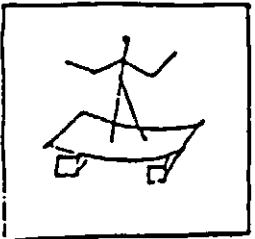

Stratified cardboard can be quite strong:

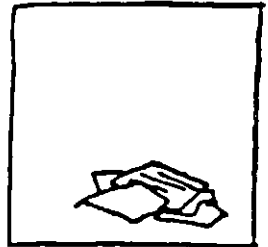

Plastic wrapping and casing is today a commonplace waste.

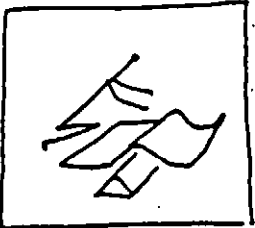

It can be easily cut or shaped before the glue gets dry.

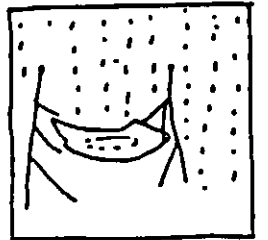

Plastic foil is an excellent waterproofing material

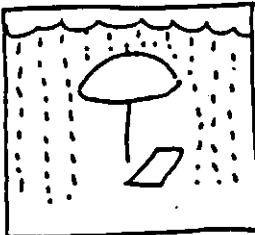

But, take care that it is not exposed to humidity,

otherwise it gets deformed.



which can protect a cardboard roof adequately.

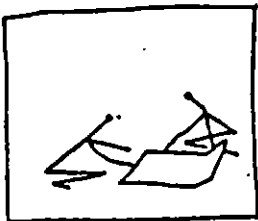

You can make many useful things out of cardboard:

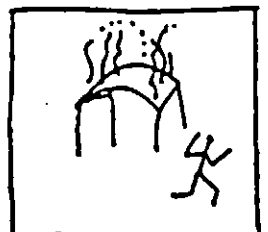

But, some plastics are highly inflammable

and need to be safely used.

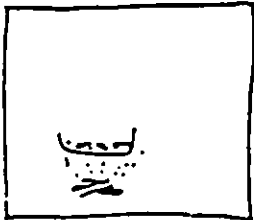

Many objects are made of plastics which become soft when heated carefully, (but most plastics burn with toxic fumes when excessively heated).

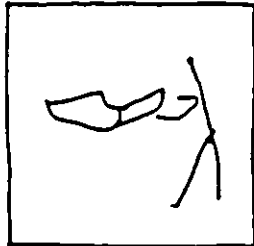

You can shape such soft plastics easily by hand

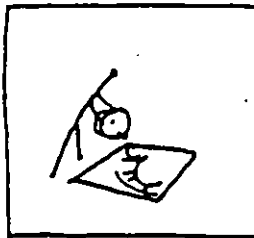

or by means of moulds.

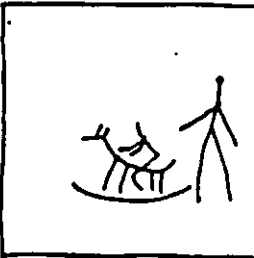

After cooling down, the soft plastic (reshaped) becomes hard again.

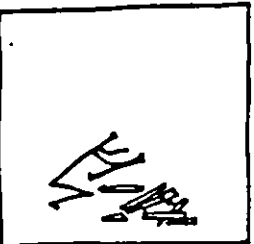

Pieces of wood, broken crates, etc. as well

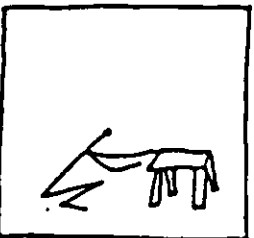

are excellent raw materials for many purposes,

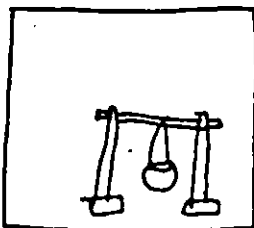

apart from being used for burning in a stove.

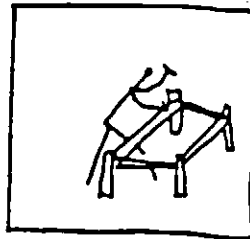

Most household objects can be made of wood.



Empty tin cans

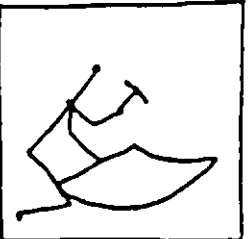

can be flattened

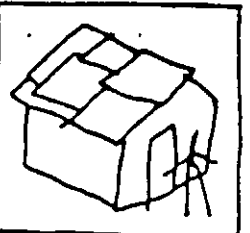

to be used as sheet metal

for the roof, for example.

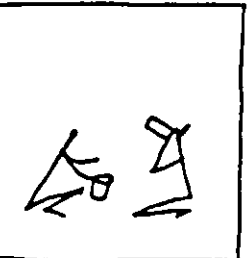

In their original form, they can serve

as plates, cups, etc.

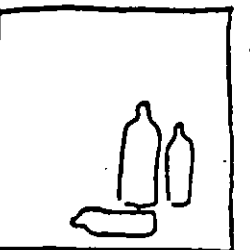

Glass bottles can have their own uses:

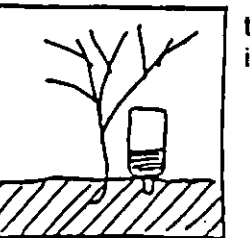

they can serve as drip irrigators,

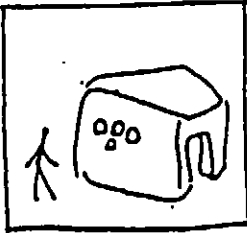

as light inlets in brick and mud walls,

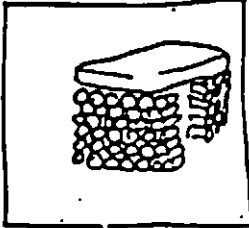

and, if you have a lot of them, as substitute bricks for making a fancy wall.

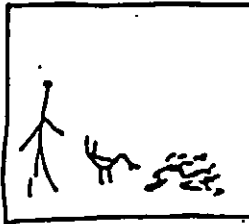

Besides these materials there is another important resource -- the organic waste originating from kitchens, etc.



After carefully removing non-organic materials from this waste,

it can be converted into compost.

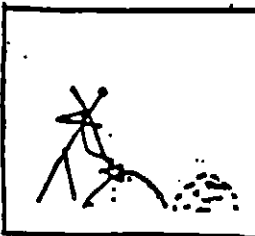

For this purpose, you can mix the rotting organic waste, with humid earth, sprinkled with water,

and remix it repeatedly over a period of time.

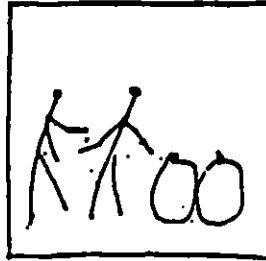

After a long while you shall get a good compost --

a fertiliser for the garden or for sale.

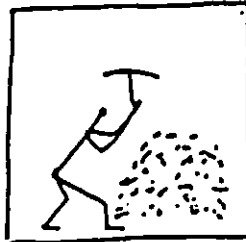

Urban waste is thus a sort of modest mine of materials

which can be used

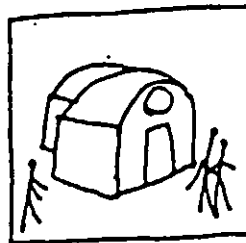

for making shelters,

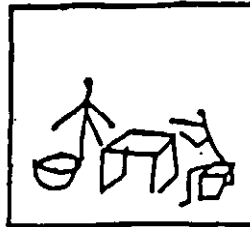

furniture and other household goods



or for small handicrafts

to make a living out of them.

How glass, tin cans, paper and plastic are recycled

SOURCE

Adapted from Activity 26 (7-12) in *Let's Reduce and Recycle: Curriculum for Solid Waste Awareness, Lesson Plans for Grades K-6 and 7-12* produced by U.S. Environmental Protection Agency 1980, revised 1990. The activity may be reproduced for non-profit, educational purposes in low-income countries provided credit is given to the original source. For further information, contact U.S. Environmental Protection Agency, 401 M Street, S.W. Washington, D.C. 20460, USA.

SUGGESTIONS FOR USE

Teachers: As reference material for increasing awareness on recycling.

NGOs, Community workers: As source material for pamphlets and posters encouraging local recycling efforts.

Discuss the sequence of steps in recycling the following materials:

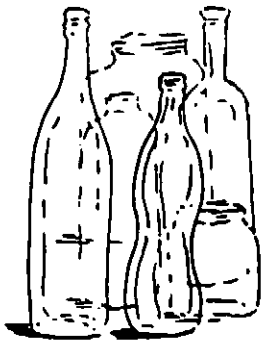

Glass is made from soda ash, sand and lime. It can remain in the environment indefinitely, where it does not break down into its organic components. To be recycled, it must first be sorted by colour and crushed into pieces called cullet. The cullet is melted down into liquid and then moulded into glass containers. Other products made from recycled glass bottles are insulation and road construction materials.



Tin-plated steel cans are made of iron ore and tin, both nonrenewable resources. The cans will eventually rust and break down, but throwing them away is a waste of valuable metals. In the recycling process, the cans are put into a huge container with holes in the bottom. This container is immersed in a caustic solution which dissolves the tin from off the cans. Then the steel cans are washed and sold as high grade steel. The dissolved tin is then removed from the caustic solution by electrolysis -- an expensive process -- and made into ingots which are then sold to companies requiring tin.



Paper is made from trees. Paper is recycled by first shredding it into small pieces and mixing it with water. This mixture is beaten into a mush-like pulp which flows onto a moving screen through which most of the water passes. The wood or paper fibres remain. The fibres are pressed through heavy rollers that remove more water and then sent through steam-heated dryers. The result is recycled paper.

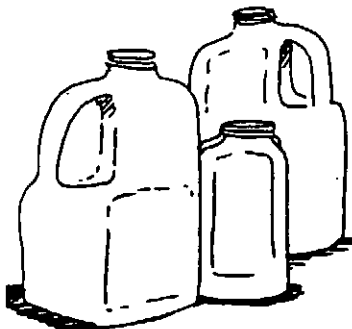

Plastic is made from petroleum. It can be recycled either as a mixture of different kinds of plastic or as a single type. Separating plastic by type enables manufacturers to produce higher quality recycled products, or those closer to what could be produced from virgin materials. Polyethylene terephthalene (PET) (e.g. soft drink containers) and high density polyethylene (HDPE) (e.g. some milk containers) are the plastics most commonly used in beverage containers and the types most easily separated. In the recycling process, plastics are melted down and reshaped into recycled products. Some of the common uses for recycled PET are fibre, structural mouldings and containers. HDPE can be recycled into bottles, toys, pipes, crates and a variety of other products. Products of mixed batch plastic recycling include trash cans, railway ties and park benches.

Recycled products Quiz

SOURCE
OUTREACH

SUGGESTIONS FOR USE

Teachers: As a classroom exercise.

Children's magazine/newspaper supplement editors: To adapt for use in an issue on recycling.

Which of the products pictured here can be made from the following four recycled materials:

- (1) glass
- (2) tin cans
- (3) paper
- (4) plastics

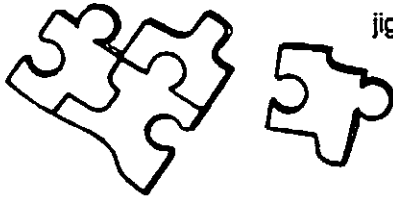

jigsaw puzzles



paint brushes

road construction materials

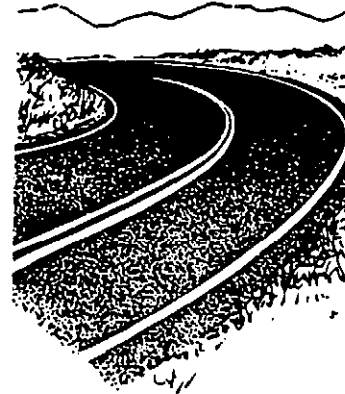

tickets



grocery store food boxes



new bottles

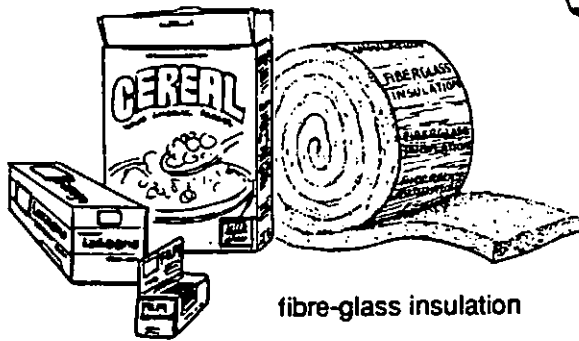

fibre-glass insulation

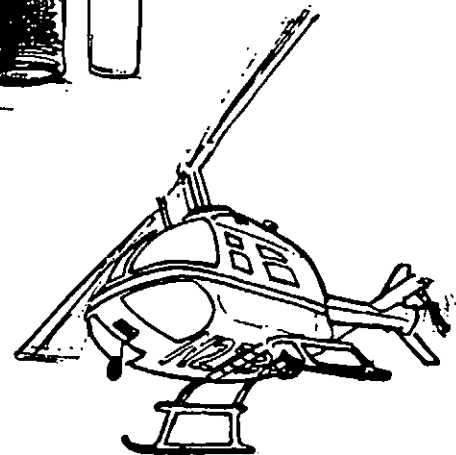

aeroplanes and helicopters



cooking pots

cans

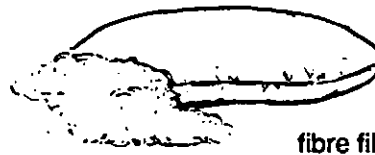

fibre filling for pillows

ANSWERS: 1. new bottles; fibre-glass insulation; road construction materials; 2. cooking pots; aeroplanes and helicopters; cans; 3. grocery store food boxes, jigsaw puzzles, tickets, magazines; 4. paint brushes, fibre filling for pillows.

How to Recycle Paper from Waste

SOURCES

Let's Reduce and Recycle: Curriculum for Solid Waste Awareness, Lesson Plans for Grades K-6 and 7-12 produced by U.S. Environmental Protection Agency 1980, (revised 1990);

Waste Away: Information and Activities for Investigating Trash Problems and Solutions for Upper Elementary and Junior High Students produced and published in 1989 by Vermont Institute of Natural Science, Woodstock, Vermont 05091, U.S.A.;

Junior Projects No. 42 "Paper", Published by Scholastic Publications Ltd. Marlborough House, Holly Walk, Leamington Spa, Warwickshire UK (1989); Impact Campaign administered for Greater Manchester Council (UK) by the Civic Trust for the North West.

SUGGESTIONS FOR USE

Teachers, Youth leaders: As a guide for practical lessons on recycling.

NGOs, Community workers, Journalists: As a resource for leaflets, community recycling projects

Recycling Paper

Only 15 per cent of the world's paper is made in developing countries, and most of that production is concentrated in a few major producers. But many developing countries want to cut down on the amount of paper they have to import, so they are trying to increase their own production of paper. As a result, the Third World has become about 85 per cent self-sufficient in paper.

Of the paper produced in developing countries, only a third is made from wood fibre. Another third comes from non-wood fibres, such as straw, bamboo and bagasse. The final third comes from recycling waste paper.

This emphasis on recycling and non-wood fibres has economic and environmental benefits: it helps conserve both material and financial resources.

Paper can be made from waste paper--and even from other waste materials such as old clothes, rags and crop leftovers such as stalks. Making paper from waste products is not a new idea. Nearly 1900 years ago, T'sai Lun, Minister of Agriculture in China discovered how to make paper from a variety of substances, ranging from the bark of mulberry trees to old fishing nets and waste hemp. These were soaked and beaten into a pulp. The pulp was then placed upon a special bamboo rack from which all the water was pressed out. The sheets were dried in the sun. For the next 500 years, the art of paper-making stayed in China, and the Chinese were the first people to use paper money. Now find out how to make paper from waste materials:

Making Pulp

Tear a piece of paper. What do you see? At the torn edge fine, thread-like wisps can be seen. (They are more clear if a magnifying glass is used.) These are fibres. Paper fibres consist of *cellulose*, the material of which many plants and especially trees and stalks, such as wheat, rice, sugar cane, are made. These materials can be used to make paper by breaking them down until the fibres are loose and free of the substances that bind them. The process of releasing the fibres is called 'pulping', and the mass of fibres, no longer held together but ready to be suspended in water for making paper, is known as 'pulp'.

1. Making pulp from old paper

You need:

- * old paper such as newspaper;
- * stirring spoon;
- * container;
- * water;
- * corn starch (optional).

1. Remove any staples in the paper, and then tear the paper into small pieces (about 2 square cm). Place the scrap paper into a container.

2. Cover with water (hot water if possible), and leave to soak for three or four days. Stir the mixture every day to help break the paper fibres down.
3. When the shredded paper suspended in the water as a slurry looks like thick soup, or oatmeal, then it is ready to use to make paper.
4. You could mix some corn starch into the mixture for smoothness and stability.

This activity lends itself to experimentation:

- * Make pulp from old newspapers and then from old exercise books. Would you have to alter the process to prepare the latter? (e.g. With tougher paper, you may have to beat with a small, smooth stone to help separate the fibres or soak paper for a longer period.) What colour is pulp made from newspaper? (newsprint makes it dark grey) From exercise book paper?
- * Make the pulp from large pieces of paper and then from tiny pieces.
- * Soak the paper for shorter and for a longer periods.
- * Add small amounts of shredded vegetable waste (e.g. orange peels, carrot tops) to the scrap paper in step 1.
- * Add different dyes to the pulp if you want coloured paper.

2. Making pulp from other waste

You need:

- * a source of cellulose - fine cotton rags, old paper, scrap wood, leftover crops, waste hemp;
 - * meat mincer or smooth pebble and large rock;
 - * water;
 - * diluted caustic soda;
 - * bowl;
 - * barrel.
1. Chop the material up very finely.
 2. To break down the fibres, boil the material in water.
 3. Put it through a meat mincer, or beat the material with a smooth stone on a large rock to separate the fibres.
 4. Leave for a day in a bowl of diluted caustic soda. Then, rinse thoroughly in cold water.
 5. Put 1 part fibre with 20 parts water into a big container (e.g. barrel), and mix thoroughly.

Making paper

To make paper, you will need:

- * a flat dish;
- * pulp;
- * an old net curtain stretched over an old picture frame, and secured with pins or tacks (or a fine wire mesh screen).

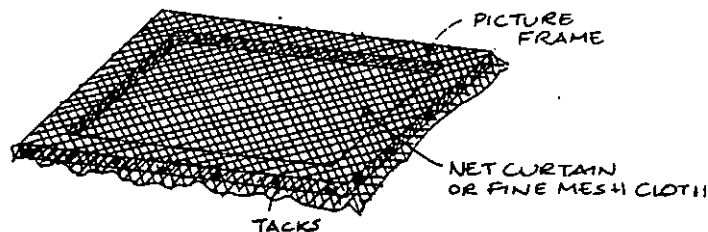

Here are two ways to make paper:

Method 1 *Follow this method if you want to make paper as an experiment, and do not want to produce large quantities of paper.*

1. Pour some pulp into the flat dish.
2. Slide the frame into the bottom of the dish, and scoop out some pulp. Spread evenly over the frame mould.
3. Lift the frame out carefully. Hold level, and let it drain for a minute.
4. Press the pulp with your hands to squeeze out excess water, and then leave the frame and pulp in a warm place for a day to allow the paper to dry. What does the paper look like?

(If the right amount of pulp has been trapped on the frame mould, the paper should have a smooth lower layer, and a slightly rough upper one. If the upper side is rough and crinkly, then too much pulp has been used. Tip it back and try again. Sometimes it helps to add more water to keep the suspension fairly thin. The finer the particles of pulp, and the thinner the layer, the better the quality of paper. When old newsprint is used to make

paper, the finished product is light grey. This is because the printer's ink is trapped in the fibres. If scrap white paper is used, the new paper will be almost white.)

Method 2 If you want to make larger quantities of paper, follow this hand-making process.

In addition to the materials listed on the previous page, you will need:

- * some sheets of felt;
- * a jar with pebbles and with a secure lid;
- * heavy weights (e.g. stones) and/or a mangle (wringer) and hardboard.

1. Follow steps 1 to 3 above.
2. Lay the frame mould, pulp side up, flat, and place a damp sheet of felt over it.
3. Gently turn the mould, pulp and felt sandwich over so the mould is on top. Carefully lift the mould off, and then cover the pulp mush with another piece of felt.
4. Roll a jar full of pebbles over the pulp sandwich to squeeze out more water.
5. Stack layers of felt and pulp alternatively. Then, put heavy weights on the pile to press out more water.
6. If you have a mangle (wringer), you can put each 'sandwich of felt, pulp and felt on a piece of hardboard, and squeeze it through the mangle. If you have no mangle, take each the 'sandwich' of felt/pulp/felt and hang up to dry. The felt will drip a lot.
7. Peel the papers from the felts and leave to dry.

Note: The leftover pulp can be strained and composted.

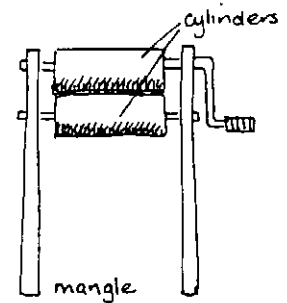

Discussion questions:

- Δ Use the recycled paper for painting or drawing with charcoal, pencil or ink. How is this paper different from other writing or drawing paper?
- Δ How are energy and natural resources conserved by making recycled paper instead of new paper?
- Δ Are there problems to recycling paper?

ACTIVITY

A Newspaper Bundler

SOURCE

Reprinted from *Help to Save the World: Programme Resource Material on Conservation* published by the World Scout Bureau in close cooperation with WWF - World Wide Fund for Nature (1990). Requests to reprint this material should be addressed to the World Scout Bureau, P.O. Box 241, 1211 Geneva 4, SWITZERLAND.

SUGGESTIONS FOR USE

Community workers: As one idea to encourage local people/businesses to recycle and earn money.
Children's magazine/newspaper supplement editors: To include in an issue on recycling.

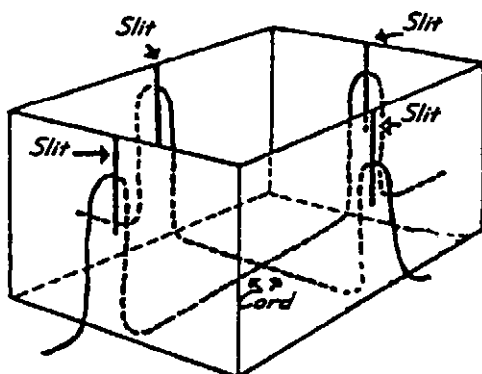

Use a wooden box or a cardboard carton.

Cut a slit (about half way down from top) in the centre of the two sides and ends. Lay two lengths of cord (or baling wire) shown in the illustration.

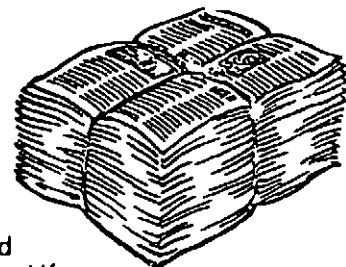

Store papers in the box. When it is filled tie the cord tightly or wire ends together. Lift out a neatly bundled stack of paper which then can be sold.

New Uses for Old Tyres and Inner Tubes

SOURCE

Developing Countries Farm Radio Network Package 4 item no.6
If reproduced, please give credit to Developing Countries Farm Radio Network

DCFRN is a worldwide information network that gathers farming information from developing countries and provides information in the form of broadcast material for communicators in developing countries. The network aims to help small farmers increase their food supply for their families, or to sell. The Network is supported by the Canadian International Development Agency, and hundreds of individual, corporate and foundation donors. For further information, contact: Developing Countries Farm Radio Network, 40 Dundas Street West, Box 12, Suite 227B, Toronto, Ontario CANADA M5G 2C2

SUGGESTIONS FOR USE

Teachers: As a source of information for lessons, flip charts, plays, stories, songs, etc.

Radio Broadcasters: The script may be adapted for local radio broadcasts.

Journalists, NGOs, Community workers: As a source of information for magazine and newspaper articles, leaflets, fact sheets, posters, extension visits.

Today, let's talk about some ideas for using things that many people throw away -- old tyres and inner tubes.

How many times have you seen an old car tyre or truck tyre that's been discarded along the roadside, -- or, perhaps, a pile of them that nobody wants? Maybe, you or someone in your family has even thrown away old tyres. Well, have you ever thought that you might be able to make good use of old tyres? Actually, there are a lot of good uses for them or for pieces of tyres, -- and for old inner tubes, too!

Maybe one or two of the uses mentioned today will be just the thing for you to try -- and it probably won't cost you any money because not many people want old tyres or inner tubes that are no longer any use for their original purpose.

Now, if you're a farmer and some of the land you grow your crops on is on a steep hillside, a bunch of old tyres may be just what you need. One way of stopping the rains from washing good soil down the slope is by placing one or two rows of old tyres across the slope, -- one row perhaps a third of the way down and another two-thirds down the slope (maybe even more rows of tyres, depending upon how much land you have). You should place them right next to each other and inside each tyre, drive a stake in the ground so that it can't possibly slip or wash down the hillside. You could even plant a shrub or tree inside each tyre. This, as well as the tyre, will help to hold the soil.

What you plant inside the tyres could be something that bears fruit or otherwise produces food of one sort or another. As you may know, legume trees are very good because other plants growing close to legumes receive an extra supply of nitrogen (a valuable plant food).

If you live where there aren't any steep slopes, maybe you're a farmer that has animals that work for you, -- animals that need a harness of some kind. -- Did you ever think that you could make a good strong harness or you could mend the harness you already have by using strips cut out of the sides of old tyres?

Tyres can be used to prevent soil from washing away down hillsides.

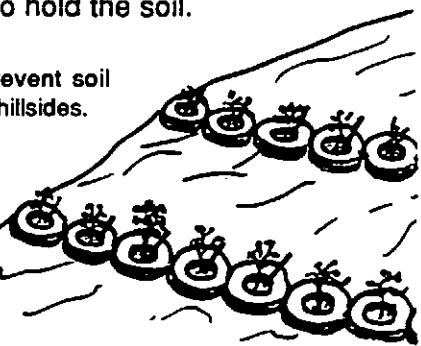

Pieces of tyre can be used for making and repairing harnesses.

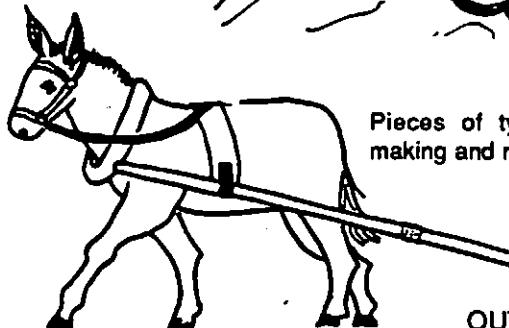

Tyres, of course, are made of a mixture of rubber and fabric. Because of this, they're really tough but with a little practice, you can cut out strips quite easily, (see box at right). First, you have to make a slit in the tyre wall using a sharp chisel or some other strong sharp tool. To cut right through, you'll probably have to hit the tool really hard with a hammer or mallet of some kind. After you've made the slit, though, you can cut it fairly easily with your good sharp machete or bush knife.

It's a good idea for someone to help you by holding the tyre still while you work on it. They can also use a stick to spread the rubber apart as you cut it. -- This will help keep the knife from sticking. Also, pouring a small trickle of water on the rubber just behind the knife will help to prevent the knife from sticking. Big, old, truck tyres are really tough, so to cut them, you may have to hammer on the back of the knife.

By the way, inside the thickened part of the tyre (the "bead") that goes next to the rim, there's some steel wire. Don't try to cut through that, -- it's so hard that it could spoil your knife

Let's go back, for a moment, to using those strips cut from the sides of tyres for making and repairing harnesses. Farmers in Papua New Guines use tyres for that. To join the strips together, they use rivets or they sew the pieces of tyre together with wire.

The easy way to make small holes for the rivets or the wire is to burn them through with a thin sharpened red hot iron that's been heated up in a fire.

Another good use for the rubber from the sides of old tyres is for making gate or door hinges. For this, if you cut out two pieces, say 10 centimetres by 15 centimetres (4 inches by 6 inches), they would make a fine pair of hinges. To attach the hinges, lay the door or gate flat on the ground and, with 2 or 3 good sharp nails, nail one half of each hinge onto it. One hinge should, of course, be near the top of one side of the door, the other hinge, near the bottom. Next pick up your door or gate off the ground and, while somebody else holds it in place, use 2 or 3 more nails to attach the other half of each hinge

Cutting old tyres

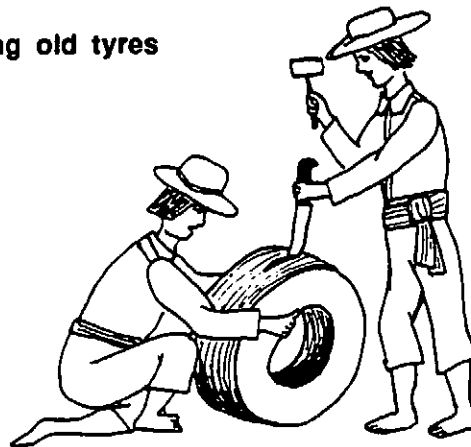

To make the first slit, it may be necessary to hit the cutting tool with a hammer. It is easier if someone holds the tyre while another person cuts it.

A little water helps keep the knife from sticking.

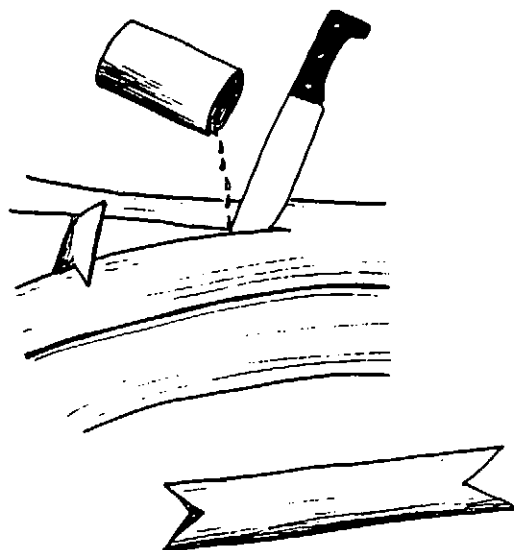

A short stick with notches in the ends helps to hold the rubber apart as it is cut.

Making holes for rivets

Heat a sharpened iron rod in a fire until it is red hot. Then, burn holes in old tyre strip for rivets or wire.

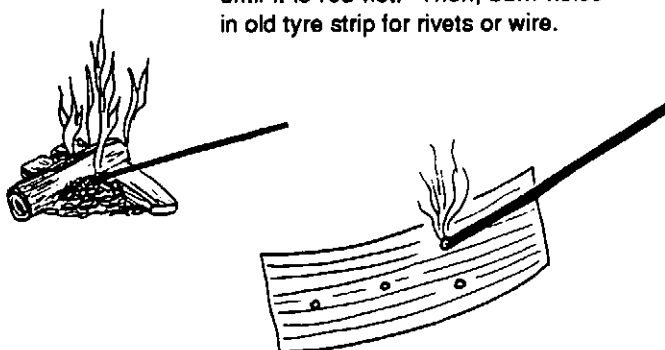

to the post that the door's going to swing from.

Hinges for small doors or gates (say a rabbit pen) could be made the same way, only out of pieces cut from an old inner tube.

Perhaps, you keep chickens and you need new feeding and watering troughs. You can make both of them from *one* old tyre, simply by cutting the tyre all the way round the outside right in the middle of the tread. Then, with the two half tyres lying flat on the ground, open side up, what could be better for your chickens to eat or drink out of?

Now, what about old inner tubes? Long, thin rubber strips cut with your bush knife or machette out of the thinner rubber of an inner tube are handy for lots of things: you can join bamboo water pipes together by wrapping the rubber strips around the joints like bandages; you can tie things down on a cart or bicycle with them; and if you need a spring for keeping a door closed, a rubber one made from a strip cut from an inner tube is often just as good as a steel spring.

So there are some suggestions. -- Next time you see an old tyre or tube that's no good for a car or truck, you might find that you could put it to good use.

NOTE: In the first suggested use for old tyres, the possibility of planting legume trees inside the tyres on steep hillsides is mentioned. There are, of course, many different kinds of legume trees. When interpreting this information in the local language for your listeners, you should refer to the kind of legume trees that grow locally and are known to your listeners.

The practical uses mentioned in this script for old tyres and inner tubes are described in *Liklik Buk: a sourcebook for development workers in Papua New Guinea* (1986) published by Liklik Buk Information Centre, Appropriate Technology Development Institute (ATDI), Unitech, PMB, Lae, Papua New Guinea.

Recycling tyres

Pieces of tyre can be used for gate hinges, door hinges, hinges for rabbit hutch

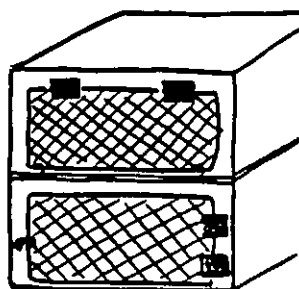
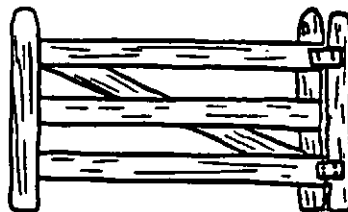
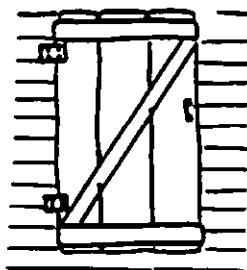

A tyre can be cut in half and used as a feeding trough

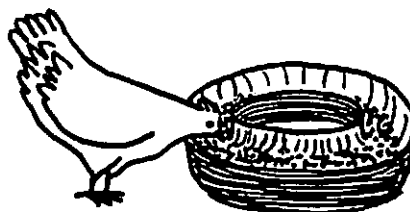

Recycling inner tubes

Inner tubes can be used as a "bandage" to join bamboo pipes together...



..as straps to tie things onto bicycles or carts..

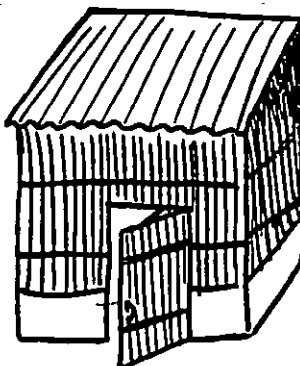
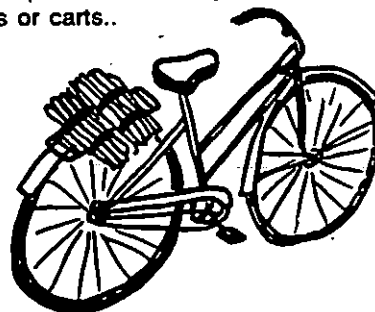

..as a door spring.

Work from Waste: Recycling Wastes to Create Employment

by Jon Vogler

SOURCE

Work from Waste: Recycling Wastes to Create Employment by Jon Vogler is published by Intermediate Technology Publications Ltd. and Oxfam, (1981, reprinted 1983), 396 pp. ISBN 0 903031 79 5 £12.95 (plus package and postage) from Intermediate Technology Publications Ltd., 103-105 Southampton Row, London WC1B 4HH, UK (tel: 071-436 9761. Fax: 071-436 2013)

SUGGESTIONS FOR USE

Community workers, NGOs, Journalists, Radio broadcasters: As a guide to help people set up recycling businesses.

Work from Waste brings together, in one book, details of appropriate technologies being employed all over the world to recycle paper, iron and steel, tin, non-ferrous metals, plastics, textiles, rubber, minerals, chemicals, oil and human and household wastes. All these materials are suitable for labour-intensive processing, often requiring little capital, and providing a cash income plus other environmental and community benefits.

The book also describes how to set up and run a small waste recycling business. Although *Work from Waste* is written primarily for use in developing countries, the technologies described will also be of interest to communities and groups practising local self-reliance in industrialised countries.

The book, *Work from Waste*, is divided into two main parts. Part I contains details of the wide range of materials that can be recycled and the processes involved. Part II explains how to go about creating work from waste materials. It is illustrated by two case studies and summarized in thirty-two short simple rules. These rules are listed below:

RULES FOR WASTE RECYCLING BUSINESSES

1. Find out which wastes occur in the district that are not being used.
2. Find out the quantities if possible.
3. Find out the uses of markets that exist before starting to collect waste material.
4. Find out the quantity and quality required, where the markets are and the price that might be obtained.
5. Decide on the type of technology needed to change the material from the form in which it occurs into the form in which it can be sold and whether further technology is desirable.
6. Remember that with simple, home-made technology you can often process material cheaply to increase its sale value and reduce transport costs.
7. Leave complicated technology until you are familiar with the product and the market and can find the money needed without endangering your business.
8. Transport is one of the highest costs in a waste business. It may decide which sources of supply or markets are economic.
9. Transport costs can be reduced by:
 - making door-to-door visits on foot with a back-up vehicles;
 - using carts drawn by people or animals instead of motor vehicle;
 - hiring vehicles for part-time work; and
 - compressing materials and organising material handling to reduce the time the vehicle is required.
10. Plan your workplace to minimise rent, transport costs, handling effort and outside interference. Decide which services and space you need now and which can be added later.
11. Although waste may be dirty, heavy, infested or low value, the people who handle it should be treated as valuable assistants and provided with reasonable pay, food and drink and washing places and treated with courtesy.
12. Management is the most important activity but is done best by people closely-involved in the

- running of the business. If all share in the management of a small business, there will be a greater sense of partnership but some do certain jobs better than others: only one person should be responsible for each activity and a procedure for taking big decisions is needed.
13. House-to-house collections should be planned to keep the distance covered low, the handling of materials easy and to get cooperation from householders by taking careful account of their social preferences.
 14. Compact materials during collection, using waste containers or other simple means.
 15. Plan your depot so that:
 - materials travel in one direction, a minimum distance;
 - there is sufficient storage space;
 - employees can work comfortably and safely; and
 - costs are kept low.
 16. By grading materials, their value is increased, often by much more than the cost of the job and additional employment can be created.
 17. Keep material clean and separate from dirty material to obtain the highest prices.
 18. When going for an interview, always wash thoroughly, be tidy and dress as smartly as you can manage. Men, wear a tie (which means a shirt as well!). Behave with quiet confidence and good manners.
 19. Find out as much as possible about the markets into which you are selling, using sources of written information such as libraries and talk to people, especially the managers of factories that use your products.
 20. Use the information you obtain to plan your marketing so you do not depend on a single outlet. Sell to final users, not middle men.
 21. As with rule number 16, be professional in your salesmanship -- in telephone calls, letters and especially visits. Plan ahead, be neat, clean and courteous.
 22. Never negotiate a price without first finding out what price you ought to get; what others get, your own costs and how much your customer needs your material. Work out the lowest price you can accept and start by asking for more.
 23. Transport is one of the highest costs in waste handling but can be reduced in many ways. Use of your own lorry is one of the most expensive forms of transport.
 24. All deliveries of material to a customer should be accompanied by suitable paperwork.
 25. The safety of your business and its people can be ensured by learning and acting on a few simple rules -- and in the long run these will increase your profits, too.
 26. By budgeting, you can spot the profitable activities and spend more money and time on them.
 27. Budgets and cost actuals take account of the depreciation of capital equipment and cash may be set aside in a savings fund so that equipment can be replaced when it is worn out.
 28. Only very simple book-keeping is needed for a small business with a book to record payments and receipts, a petty cash box, a current account at the bank and a deposit account for the saving fund.
 29. Sales and cost actuals can be compared with the budget to find out what is going wrong, how to put it right, improve the business and budget better in future.
 30. Avoid cash crises by budgeting cash movement, controlling debtors and getting support from your bank manager.
 31. The profit per tonne of each kind of material can be calculated to show which collections should be increased and which should be stopped.
 32. By learning how to improve your budgeting, accounting and costing you will improve your control of your business and your profits.

Starting a Vegetable Waste Recycling Business

SOURCE

The following story is based upon information in *Work from Waste: Recycling Wastes to Create Employment* by Jon Vogler (published by Intermediate Technology Publications Ltd. and Oxfam, (1981, reprinted 1983) If reproduced, please acknowledge original source.

The book, *Work from Waste*, is divided into two main parts. Part I contains details of the wide range of materials that can be recycled and the processes involved. Part II describes how to set up and run a small business recycling wastes. For further information, contact Intermediate Technology Publications Ltd., 103-105 Southampton Row, London WC1B 4HH, UK (tel: 071-436 9761. Fax: 071-436 2013)

SUGGESTIONS FOR USE

Radio Broadcasters: As an introduction to discussions on setting up a recycling business.

Teachers, community workers: As a case study for discussions on starting a community recycling project.

Children's magazine/newspaper supplement editors: As a basis for a comic strip on starting a recycling business.

Chapter 1: WASTE SUPPLIES

It was dusk. At the dump, Wanda emptied the box of trash. As she turned to leave, she noticed her friend, William. He was squatting amongst the rubbish, looking glum.

"What's matter, William?" asked Wanda.

"My dad lost his job, and now only my brother, George, has work."

Wanda was sympathetic. "I know how you feel. Since my dad left...well, things have been tough for us, too. My mother has a cleaning job, but it doesn't pay well. And there are eight of us to feed...."

"I thought I might find something here to sell," said William. "But there's not much left now they've searched through it." He pointed to a group of women and children nearby who were hunting through the rubbish.

The two stood in silence for a few moments. Suddenly, Wanda realised her feet were beginning to sink into the rubbish mound. She looked down, and saw that she was standing on a pile of vegetable peelings.

"Well, they don't seem to be collecting this waste," she said wryly. Then, an idea struck her.

"What about these peelings?" she wondered aloud. "Maybe we could do something with them."

William stared at Wanda. "Like what?"

"Well, vegetable waste makes good compost to fertilize the fields and vegetable gardens. We can make compost, and sell it to farmers and vegetable growers."

"We'd need to collect a lot of compost to make any money, wouldn't we?"

Wanda wasn't daunted. "Every household in

the district gets rid of vegetable waste. I've just dumped some here, too."

"Well..." said William cautiously. "Your idea may work. But we have to look into it more carefully. After all, why hasn't anyone already thought of it? I need money for our family, and I can't afford to go off on a wild goose chase."

Wanda understood. "First, let's work out how much vegetable waste we can collect. At home, I'll collect each day's peelings into separate bags, and after a week, I'll take the seven bags to the market. I'll borrow a scale from one of the stalls, and weigh the peelings. You do the same. That way we can work out how much vegetable waste an average family makes."

"But how can we find out how many families there are in the district?"

"I'll go to the mayor's office at the Town Hall to find out how many families live in the settlement."

"Okay," said William catching some of Wanda's enthusiasm. "We'll meet next week to see what we've both learned."

During the next week, Wanda went to the Town Hall. There, a clerk told her that there were about 20,000 people in the settlement, but the number of families was not known.

"Families keep splitting up and changing," said the clerk. "But there are probably about seven people in each family, which makes around 2,850 families."

William was busy, too. He made several trips to the dump to study the scavengers. He saw people collecting old bottles, cans, plastic

Weights of waste per household in grammes

	Wanda's family of eight people	William's family of ten people
Monday	420	510
Tuesday	640	620
Wednesday	200	250
Thursday	610	700
Friday	520	540
Saturday	400	360
Sunday	780	800
Total	3570	3780

containers, old tyres and rags, but no-one seemed interested in collecting vegetable waste.

At the end of the week, the two children met at William's home. They had both weighed their peelings. They calculated that the average was just over half-a-kilo per family per day. "Half-a-kilo per family per day from each of the 2,850 families makes 1,425 kilos a day, which is about 10,000 kilos (1,425 x 7) a week or 10 tonnes."

"That's a lot of vegetable waste," said William. "I wonder if we can find a market for it all."

ACTIVITY:

What wastes occur in your district that are not being used? Carry out a supply research project in your district. Find the answers to the following questions:

- What waste is available?
- Where does it come from?
- How much is there?
- What will it cost?
- Of what quality is it?

The Learning Leaflet no. 71: "What a Waste!" may provide some helpful hints for your research.

Chapter 2: FINDING A MARKET FOR WASTE

Wanda and William were discussing ways to sell vegetable waste.

"Everyone knows that vegetable wastes make good compost to fertilize the fields and vegetable gardens," said Wanda. "All we have to do is make the compost and sell it to farmers or vegetable growers."

"But if it's so obvious," said William, "Why haven't people tried making use of it before now. The farmers round here must be too poor to buy compost."

"I think people who grow vegetables to sell in the market would buy it," said Wanda. "They make plenty of money by charging high prices."

"Let's go and ask them," responded William.

So the two went to the local vegetable market to talk to the vegetable sellers.

"I can't afford to buy compost," said one.

"Neither can I," said another.

Then, Wanda asked a person who ran a large vegetable stand with several people working for him.

"Look at my vegetables," was his response. "See how healthy they look! I spend money on chemical fertilizers."

William turned to Wanda.

"Perhaps, we should visit the local farmers' store, and find out how many farmers buy fertilizer."

The manager of the local store was not helpful. He did not want to answer their questions.

"I'm not going to tell you who buys fertilizer. You're probably from the store across town, and you want to take my customers away from my business."

"That man was rude," whispered Wanda as they left the store. "Let's just stop people who are going in and out of the store, and ask them questions instead." William agreed. They tried speaking to several people, but when the store owner realised what was happening, he stormed out of the shop waving a broom in his hand, and yelled at the two children.

"Go away, and mind your own business," he yelled.

The two children dashed away.

"I'm beginning to think no-one will buy compost," said William, as they stopped to catch their breath.

"You may be right," said Wanda, "But I've an idea. Let's ask the local agricultural extension

worker. She should know if farmers would be interested in buying compost."

The local extension worker told the two children what they were beginning to discover for themselves.

"It's a shame, but very few people use compost these days. Those who can afford it buy chemical fertilizer; those who cannot do without, and, of course, could not afford to buy from you."

They thanked the extension worker for her advice, and walked away.

Wanda was disappointed, "So there's no market for compost made from waste vegetables."

"At least we found that out before we wasted many hours making and trying to sell compost to people who do not want to buy it," said William. "We'll just have to think of another waste material to collect."

Wanda did not want to give up her idea easily. "Maybe we could persuade the farmers of the value of compost so they *will* buy it."

"I don't think that'll work," replied William, "The farmers may already realise the benefit of compost. They just don't have any spare cash."

"Well, let's find another market for the vegetable waste," said Wanda.

They walked in silence for a while, both lost in thought.

"I've an idea," Wanda said suddenly. "Vegetable waste can be fed to pigs."

"Who keeps pigs?" asked William.

"We can find out," Wanda replied. "Let's go back to the farmers' store, and find out who buys pig feed!"

"Oh no," groaned William. "After what happened last time. "

Wanda smiled slyly. "We'll won't tell the shop-keeper we're trying to find a market for pig food. Come on."

The store owner's face grew stern when he saw Wanda and William enter his shop. "I thought I told you to keep away."

Wanda smiled, "We just want to ask you a question. We need to buy some pork, and we thought you'd be able to direct us to some local pig farmers."

The shop-keeper looked dubious, but after a moment's pause he gave them some names.

Afterwards they went to Wanda's home to discuss their scheme. Wanda's mother had just

returned from her cleaning job, and listened to the conversation.

"We've got some names of pig farmers, but we must find some more."

"We can try asking the local veterinary," suggested William.

Wanda's mother chipped in, "He lives on the outskirts of town on the road past the old mission hall."

An hour later Wanda and William were talking to the vet about their business idea.

"Here are some names of pig farmers," he said, jotting down some names and addresses. You might also try the council office. Ask for the inspector who checks on swine disease." He reached over his desk to pick up the local telephone directory.

"You might also try looking in the classified section that lists goods and services in alphabetical order."

William turned the pages, and ran his finger down one page.

"Physiotherapists, Piano Tuners, Picture-framers...Here it is..Pig Farmers."

The two children wrote down the names and addresses. Wanda thanked the vet.

"Tomorrow, we'll start visiting the pig farmers to ask if they would be interested in buying 10 tonnes of pig food per week."

The next day, Wanda and William eagerly set out, armed with a pen and paper, and their list of pig farmers. A few hours later, they collapsed in front of William's home. They had walked several weary miles from one pig farm to the next in search of answers to their questions.

"I understand now why nobody is selling vegetable waste to pig farmers!" said Wanda, rubbing her feet. "The pig farms are scattered all over the district."

After a few minutes, she began looking through the notes they had taken.

"Many farmers receive food wastes from their neighbours for their pigs, but most must also buy extra grain from the farmers' store. All the farmers told us that they would buy vegetable wastes if they were available and cheap. Some even said that if cheap food was available, they could keep more piglets for fattening instead of selling them to the market."

William propped himself up on his elbow.

"But the farmers did say that the waste would have to be fresh, and they would have to be

delivered in the mornings when the pigs are fed." He paused. "What do you think 'fresh' means? "Does it mean the same day? The next day? Less than two days old? We didn't think to ask. We'll have to find out." Wanda looked back at their notes.

"Anyway, we've got a list of ten pig breeders scattered around town who would like to buy vegetable waste providing it is cheap and fresh, and another five who get theirs from their neighbours. Of the ten, four have forty animals and the other six have only twenty. How many animals is that?"

"280," said William promptly.
"Right. Now each animal on average will eat

two kilos per day, so that makes 560 kilos - about four tonnes per week."

"That's much less than the supply available." said William.

"But it's enough to start a business," replied Wanda. "Besides, there are other pig breeders we have not visited, and some who currently buy from their neighbours but who might come to us if we persuade them. We can do this by selling our material at a cheaper price than that of grain."

She beamed at William. "We have a supply of waste and a market for it. We're in business!"

William returned the smile, but added, "It's a start, Wanda. But we've a long way to go..."

ACTIVITIES

1. Chapter 2 describes the *market research* that Wanda and William undertook. Market research is essential before putting time and money into the collection or production of a recycled product. But what if market research reveals a negative answer? This happened to Wanda and William when they discovered that no-one was likely to buy compost. What alternative actions did they consider? (1- giving up the idea of collecting vegetable waste and collecting something else; 2 - persuading people of the value of compost so they would buy it; 3 - finding another market for vegetable waste) Which alternative did they opt for? (3)
2. Identify a supply of waste that is available in your locality and then try to identify what uses or markets exist for the waste. The key to this research is to ask people.
3. In the story, "Starting a Waste Recycling Business", Chapter 1 illustrates the first two rules laid down in the book *Work from Waste* (see page 21):
Rule 1: Find out what wastes occur in the district that are not being used.
Rule 2: Find the quantity if possible.
Chapter 2 illustrates rules 3 and 4:
Rule 3: Find out what uses or markets exist before starting to collect waste material.
Rule 4: Find out the quantity and quality required, where the markets are and the price they might pay.
Discuss in class some of the other rules mentioned in the book (and on page 21). Apply these rules to the business that Wanda and William are setting up. Complete the story about Wanda and William's business. You can do this through class discussion, group activity, in story-telling or plays. Describe how William and Wanda might organise the collection, storage and transportation of the waste; what kind of premises they might need for their business; what health and safety hazards they have to consider; how to keep accounts, and how to develop the business.

ARTICLE

Desert Food with Petroleum Waste

SOURCE

Peter O'Neill *People* Vol. 18 No. 3 (1991) published by International Planned Parenthood Federation, PO Box 759, Regent's Park, London NW1 4LQ UK. If reproduced, please credit original source.

SUGGESTIONS FOR USE

Radio broadcasters, Journalists: As a news item.

A world breakthrough has been made to help grow wheat and rice in the desert, using an invention to recycle petroleum and nuclear waste.

An Egyptian scientist, Dr. Reda Aly Ibrahim Azzam, says the waste from petroleum

refineries, petrolchemical processes and nuclear power plants is turned into a gel, which helps render soils suitable for any staple food. The successful growth of rice and wheat in desert areas using the gel is proof that the invention sharply increases the productivity of sandy soils.

The 'reclaimer-ameliorator-polymeric gel (RAPG)' helps stabilise sand, retain moisture, prevents biodegradation and controls soil erosion.

Dr. Azzam works at the Inshas Nuclear Research Centre in Cairo, where he heads the project for Sandy Soil Reclamation and Arid Lands Plantation. He says the gel is affordable and within the means of rural communities.

For this breakthrough, Dr Azzam was awarded the African Environmental Invention Award. The environmental award, jointly sponsored by the United Nations Environment Programme (UNEP), the World Intellectual Property Organization (WIPO) and the Union of African Journalists (UAJ) is available only to African inventors working on the continent.

ARTICLE

Recycled Plastic Sheets

SOURCE

Taken from "New Life for Plastic Sheets" by André Lachance in *IDRC Reports* Vol. 21 No. 2, July 1993. *IDRC Reports* is published quarterly by the International Development Research Centre (IDRC) of Canada. For further information on IDRC, contact IDRC's Head Office, PO Box 8500, Ottawa, Ontario, Canada K1G 3H9. If this article is reproduced, please credit original source.

SUGGESTIONS FOR USE
Radio broadcasters,
Journalists: As a news
item.

In Jordan, market gardening is a growing business. Although it did not exist in 1967, greenhouses now cover 10,000 hectares.

Why has market gardening become so popular? Because the country suffers from a chronic water shortage. Hothouse cultivation produces higher yields than traditional farming methods, and it saves the maximum amount of water.

But there is a major drawback. The 4,500 metric tons of plastic sheeting used to cover the hothouses deteriorates in less than two years, mainly because of the sun's ultraviolet rays.

The used hothouse covers are often burnt, left in the fields, or even eaten by cattle which die as a result.

But now scientists from Jordan and Canada have developed a way to recycle the used plastic membranes. Researchers at the Royal Scientific Society in Amman, Jordan, with the help of researchers from Montreal's McGill University, have produced a multi-layered polyethylene membrane which incorporates a high proportion of the used hothouse covers.

The double-layered membrane is of the same quality as that of other widely used membranes. Recycled polyethylene makes up nearly 60% of the mixture. The outer layer is made of pure resin. Says one of the Jordanian scientists, Nadia Khraishi, "We are still studying the effects of accelerated aging on this new

membrane, but the results so far are very encouraging!"

The new product costs less than that of the single-layered membranes usually found on the Jordanian market. Its cost is around 15% to 25% lower as a result of using recycled plastic, which is available locally in large amounts. This is a very important factor for a country like Jordan, which has to import most of the pure plastic it needs.

The Jordanian project is apparently the first to recycle used plastic on a large scale. The process developed by the Jordanian and Canadian scientists probably will be patented and will be transferred to local industry, which will use it to produce a less expensive, but high quality multi-layered membrane that is better suited to local needs.

"As the problems created by the plastic waste are reduced, and use of the membranes becomes more widespread, agricultural productivity will increase," reckons Dr. Musa Kamal, head of the McGill University team of scientists.

One thing is certain. In addition to helping 40,000 farmers in Jordan, the process could also benefit other countries with semi-arid regions. The technology has already been transferred from Jordan to a project in Egypt, where it is being adapted to suit local conditions.

Make Yourself A Plastic Raincoat

SOURCE

Reprinted from: *BOTHER* issue No. 136 (September - Oct. 1985) "Do It Yourself: Recycling for a Fairer World" published by Oxfam's Youth and Education Dept., 274 Banbury Road, Oxford, OX2 7DZ, U.K. The material may be reproduced for non-commercial, educational purposes in low-income countries provided credit is given to Oxfam.

SUGGESTIONS FOR USE

Teachers, Youth Leaders, Community workers: As a practical recycling activity.

Plastics may be harder to recycle than paper or glass, but it is possible to make good use of them. Here's how to make a home-made plastic raincoat.

You will need:

- two very large clean plastic bags
- scissors/sharp knife
- needle, thread (could be twine, string, fishing gut or wool)

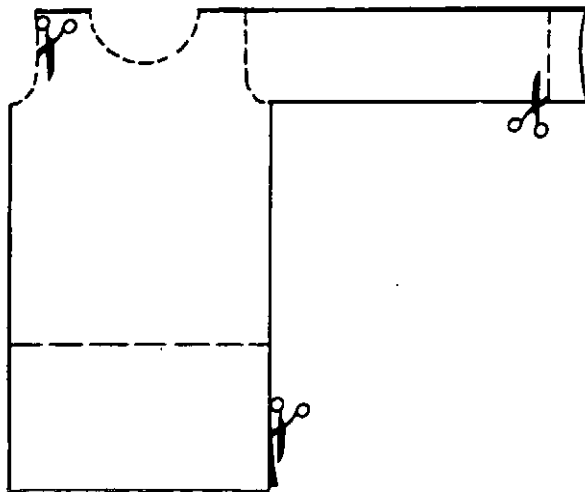
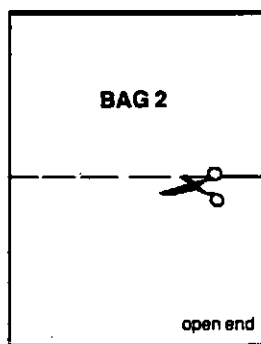
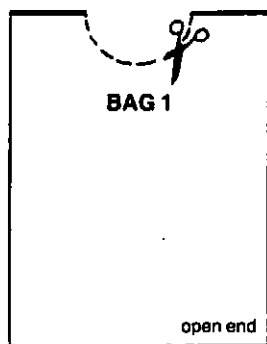

1. Take bag number 1. Cut a small circle in the top along the closed end big enough for your head to fit through. Take bag number 2. Cut it in half and cut open the sides of the bottom half – you now have two squares. Fold these two squares lengthwise – these are your sleeves.
2. Cut two thin strips off along the side of bag number 1. These openings must be the same size as the folded sleeves as this is where the sleeve fits.

Sew your sleeves into these openings.

3. Cut the sleeves to the right length.
4. If you are tall, you might get wet knees because the raincoat is too short. You can join the other half of bag number 2 to the bottom of your raincoat. Then cut two slits in the sides of the raincoat up to your knees. This will make walking easier.

Two Young Brazilians making a Difference by Brigitte Duchesne

SOURCE

Reprinted from "Brazilian Children Participate in Environmental projects" by Brigette Duchesne, Information Officer, UNICEF Geneva, in *EDev News*, September 1993 Vol.4 No.2. published by the Education for Development Section, UNICEF. If reproduced, please credit Brigette Duchesne/UNICEF *EDev News*. For further information, contact Education for Development, UNICEF, Palais des Nations, CH-1211 Geneva 10, SWITZERLAND.

SUGGESTIONS FOR USE

Teachers: As inspiring stories to motivate students to take some local recycling action.
Radio broadcasters, Journalists, NGOs: As inspiring stories to motivate local recycling initiatives.

In northeast Brazil, a boy and a girl are taking environmental matters into their own hands. Gustavo dips into a bucket full of water and shredded paper; the

raw material of his school's recycled paper project. Ana Alice hands a pamphlet to tourists — an anti-litter message she convinced local authorities to print for her

ecology group.

Gustavo, 16, goes to the *Presidente Arthur da Costa e Silva* school in Mustardinho, a small community at the edge of Recife.



A UNICEF-supported pilot project at his school teaches children how to recycle paper.

His school principal, Maria Rosa Assunção Soriano, says that the whole school participates in the project. "Although there are only a few students who are actually producing the recycled paper, all our pupils are involved by bringing old notebooks, newspaper and computer print-outs to the school. This scrap paper is placed in a large bin in the back of the room," she says.

Maria Rosa explains the process while Gustavo demonstrates by producing a few sheets of recycled paper. As Gustavo goes to work, the principal says: "They not only comprehend the recycling process itself but they can also explain the benefits of recycling."

First, the scrap paper is shredded and left to soak in water for 24 hours. A mixture of one part paper to two parts water is then poured into a blender, which further liquifies the solution. "We used to use an ordinary home blender but, thanks to UNICEF, we now have an industrial-sized blender," Gustavo says.

As he looks up from his task, the gleam in Gustavo's eyes shows his genuine interest in the project. Overcoming shyness, he talks about the process: "Sometimes we have to add glue in order to help the fibers stick together. The pulp solution is then put into another bin. Using a screen, you capture an even layer of pulp which, once the water is pressed

out and hung to dry, will become a future piece of paper."

The paper is a popular product. It is used throughout the school, and even tests are printed on it. The biggest demand has come from a government ministry. The ministry, which was very supportive of the project, purchased the recycled paper for use during an environmental seminar. Maria Rosa recalls: "We had to produce thousands of pieces of paper manually. The boys came after school and throughout the weekend. They are involved and very dedicated."

In a neighbouring Brazilian state, another child is participating in an environmental project. Ana Alice is a natural leader. This charis-

matic 12-year-old heads the local theatre group. And she recently created an ecology group. While children are attracted by her style, adults appreciate her common sense. She likes to confer with her teachers and the municipal authorities when she has an idea.

Without being asked, Ana Alice shares her story. "When tourists began coming to the Icapui and throwing garbage around, I knew I had to take action. I went to the town authorities and they produced a pamphlet which the group took turns handing out to motorists as they arrived in town," she says.

The town's former mayor, Dedé Teixeira, knows Ana Alice. He speaks of her like a proud father.



An entertaining and instructive cartoon booklet teaches students at Gustavo's school about the process of recycling.

"She is a very active resident of our community. If you go to the marketplace, you will find members of the ecology group policing, making sure that the vendors keep their areas clean. Our market has never been so clean! Ana Alice talks to the market janitor regularly to remind him about the importance of a clean and safe environment."

In addition to these actions, the ecology group has confiscated the bird cages and slings in town. They also asked the authorities to paint a billboard beside the lobster

fishing area to instruct fishermen not to take the female lobsters. They even persuaded the Ministry of Culture, Sports and Environment to fine a citizen who had decided to chop down a century-old tree. Now they want to start a tree nursery.

In Brazil, children's rights have been placed at the top of the political agenda. Accordingly, children feel like valued members of their communities and, therefore, become active partici-

pants. Competent and caring adults can bring even more confidence and enthusiasm to children. By encouraging children to participate, adults introduce them to the idea of having a voice — having an active role to play in creating the change that will shape a more positive future. Hand-in-hand with supportive adults. Gustavo of Mustardinho and Ana Alice of Icapui feel they can make a difference in their world.

ACTIVITY

Muscle-saving Can Crusher

Good for flattening tin cans for recycling or for easy disposal

SOURCE

Reprinted from *Help to Save the World: Programme Resource Material on Conservation* published by the World Scout Bureau in close cooperation with WWF - World Wide Fund for Nature (1990). Requests to reprint this material should be addressed to the World Scout Bureau, P.O. Box 241, 1211 Geneva 4, SWITZERLAND.

SUGGESTIONS FOR USE

Community workers: As an idea to help local recycling efforts.

Children's magazine/newspaper supplement editors: To include in an issue on recycling.

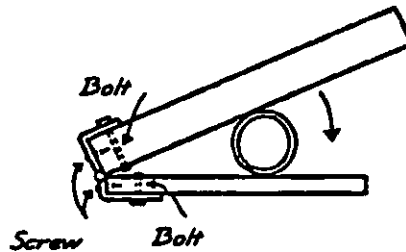
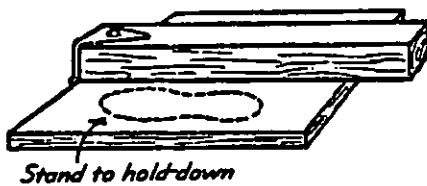

First cut out can ends (tin cans only)

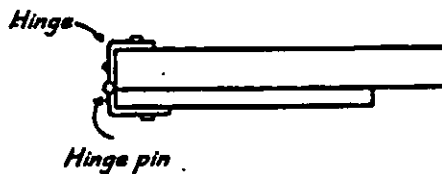

Store cans in cardboard box

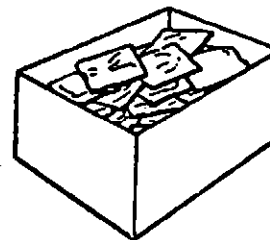

Issue 94

Waste part 4: What to do about Hazardous Waste

CONTENTS

	Page(s)
Location map	ii
How to use this pack	iii
Hazardous waste	Questions & answers 1-3
Bike and bike products	Class activity 4-5
European waste wraps Pakistani sweets	News brief 6
Indonesia's scavengers seek ban on waste imports	News brief 6-7
Hazardous waste on the Mexico-US border	Activity 7-8
Plastics: trashing the Third World	Article 8-9
A junk trap!	Puzzle 10
Deadly litter chokes livestock	Article 10-11
Adventures of Ranger Rick:	
Rick and the gang learn about a trashy problem	Fiction 11-13
The Basel Convention	Article and activities 14-16
Keeping tabs on toxics	Article 17-18
Household products: potential hazards	Chart 18-19
What to do with hazardous waste	Activities 20
Odd one out	Puzzle 21
Use safer alternatives to house and garden 'toxics'	Activities 21-23
Mobilising against toxic waste	Article 23
Oil spill	Article 24-26
Cleaning up oil spills	Class/group activity 26

LOCATION MAP

The map below shows the location of countries mentioned in OUTREACH issue no. 94:

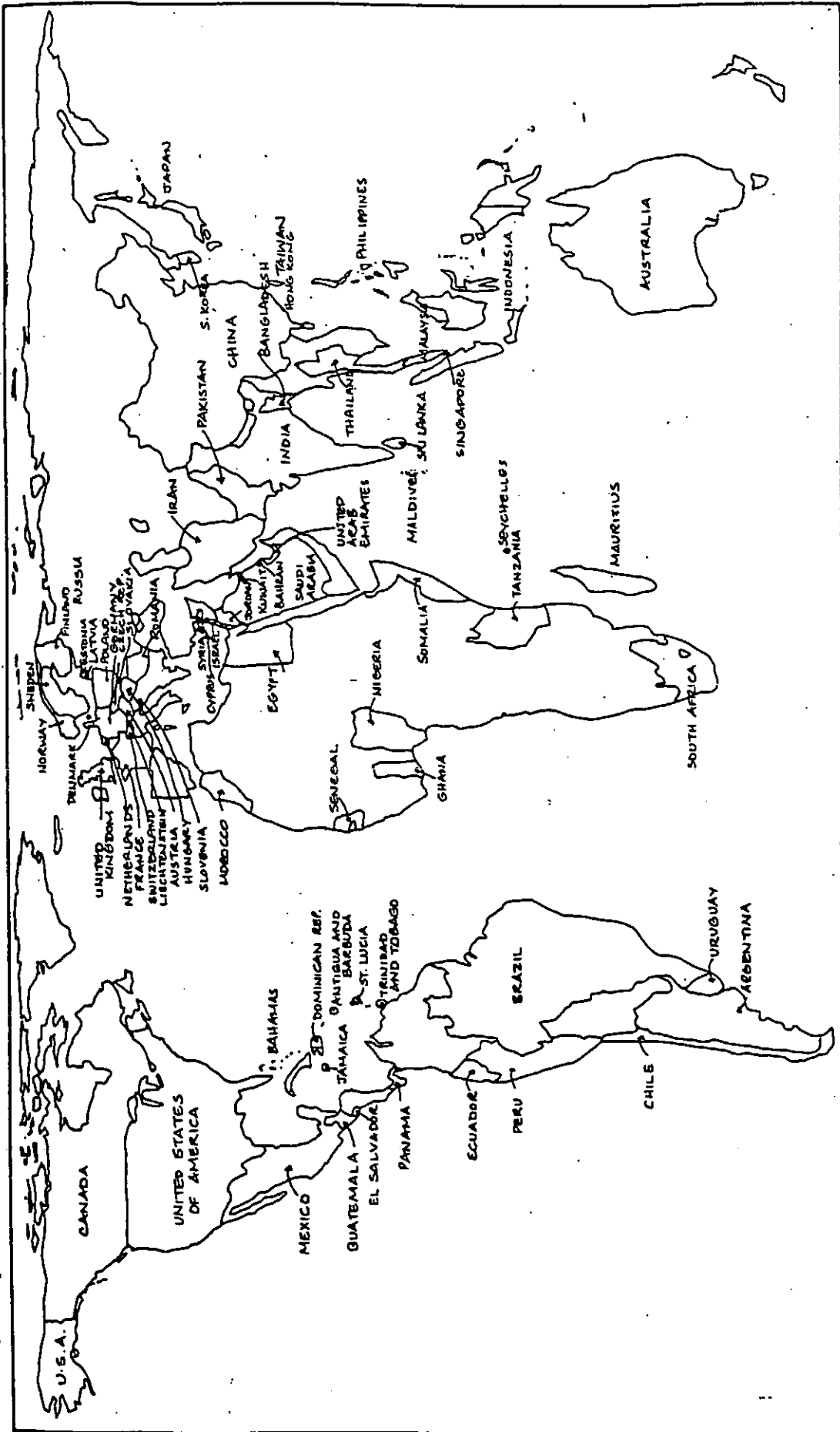

USEFUL CONVERSIONS FACTORS

linear measurements: 1 in. = 2.54 cm. 1 yd. (36 ins) = 0.91 m.
 square measurements: 1 acre = 0.42 Ha. (1 km.2 = 100 Ha.)
 weights: 1 long ton (2,240 lb) = 1.02 metric tonnes

1 mile (1 760 yd) = 1.61 km.
 1 sq. mile (640 acres) = 259 Ha.
 1 short ton (2,000 lb) = 0.91 metric tonnes (1 metric tonne = 1,000 kg.)

How to use this OUTREACH Pack

Issue 94: Waste part 4 - what to do about hazardous waste

This pack, the fourth in a series of five OUTREACH packs that covers waste and recycling, focuses on hazardous waste. Hazardous waste is defined, and there are materials aimed at increasing awareness of how people and other living things are exposed to hazardous waste. Part of the pack explores the issue of the hazardous waste dumping in Third World countries. Practical suggestions are included that encourage the use of safer alternatives to toxic materials in order to reduce hazardous wastes.

Other packs in the waste and recycling series include three more general packs and one Learning-By-Doing leaflet pack:

91: Global problems, local solutions;

92: Conserving natural resources;

93: Recycling;

95: Learning-By-Doing leaflets on waste and recycling.

At the beginning of each segment there are suggestions as to how the material might be used by multipliers. Here are some general suggestions:

- * **Community workers** running campaigns against hazardous waste might get inspiration (page 23) and a few practical tips from this pack (pages 8-9; pages 14-20 and pages 21-23).
- * **NGO Representatives** might use pages 18-19 and pages 21-23 to form the basis of a leaflet or meeting for household members warning them of the dangers of various household 'toxics', and ways to avoid their use.
- * **Newspaper editors** might insert "junk trap" and "odd one out" in a children's page on hazardous materials and the dangers of waste.
- * **Public health officials** might spread the messages contained in pages 17-18 and 21-23 to health workers in the field.
- * **Newspaper/radio reporters** covering local stories of toxic waste dumping, might use the pack for background information.

Hazardous Waste

SOURCE

Jorge E. Hardoy and David Satterthwaite, *Squatter Citizen: Life in the Urban Third World* (1989) (Earthscan Publications Limited, 120 Pentonville Road, London N1 9JN, UK)

World Commission on Environment and Development, *Our Common Future* (1987) (Oxford University Press, Walton St. Oxford OX2 2DP, UK)

Greenpeace leaflet: *International Waste Trade* (Greenpeace, 11436 U Street, NW, Washington, DC 20009, USA)

Please acknowledge original sources.

SUGGESTIONS FOR USE

Teachers, Community workers: To use to increase awareness of hazardous waste issues. The material may be used as background information for teachers/community workers, or as the basis for class/group discussions and activities.

Journalists, Radio broadcasters: As the basis of newspaper articles and radio scripts on hazardous waste to increase awareness on the subject.

Q. What is a hazardous waste?

A. A hazardous waste is a substance that is no longer useful but which has the potential to inflict damage on either human health or on the natural environment.

Q. Are there different kinds of hazardous wastes?

A. Yes. Some are highly inflammable, such as many solvents used in the chemical industry. Some are highly reactive, and can explode or generate toxic gases when coming into contact with water or some other chemical. Some wastes are corrosive, and others have disease-causing agents: for instance, sewage sludge or hospital wastes often contain bacteria, viruses and cysts from parasites. Some wastes are poisonous, such as cyanide, arsenic and many heavy-metal compounds, and many are carcinogenic (cancer-inducing), see box: Hazardous substance characteristics.

HAZARDOUS SUBSTANCE CHARACTERISTICS

TOXIC

A substance that is potentially harmful to human health, can cause cancer or birth defects, and can contaminate, harm or kill fish or wildlife.

Examples: Lead, mercury, pesticides.

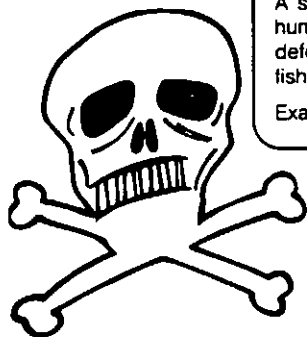

CORROSIVE

A highly acidic or base substance that corrodes storage containers or damages human tissue if touched.

Examples: Battery acid, bathroom cleaners, pool chemicals.



IGNITABLE

A substance that can explode, catch on fire, or emit toxic fumes or gases into the environment.

Examples: Fuels, some cleaning fluids, some furniture polishes.

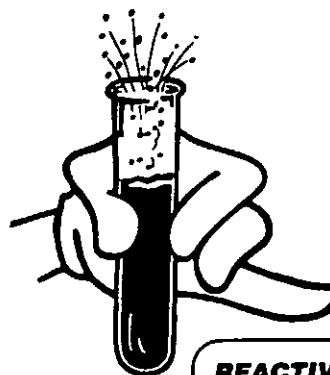

REACTIVE

An unstable substance that reacts strongly (including explode) if exposed to heat, shock, air, or water.

Examples: Bleach and ammonia when mixed together; munitions.

Source:
California Department of Toxic Substances Control,
Public Education Unit

Q. How much hazardous waste is generated?

A. As definitions of hazardous waste vary, global estimates have a wide margin of error. The United Nations Environment Programme estimates that worldwide, some 338 million tonnes of hazardous waste are produced every year -- 275 million in North America and 25 million in Western Europe.

Q. Who generates hazardous waste?

A. Industrialised countries generate about 90 percent of the world's hazardous waste. Most toxic waste comes from chemical industries. However, significant quantities of hazardous wastes come from primary and fabricated metal and petroleum industries, pulp and paper industries, transport and electrical equipment industries and leather and tanning industries.

Q. How is hazardous waste disposed of?

A. Disposing of acids, pesticides, dioxins, toxic ash, radioactive waste, sewage sludge and other types of hazardous waste is the most dangerous waste problem. If such waste is buried, great care must be taken so that it does not contaminate underground water sources. If stored in drums, care must be taken that the drums do not corrode. Most toxic waste remains toxic so simply storing them does not solve the long-term problem.

Several disposal methods, each with varying degrees of safety and expense, have been developed by the industrialised countries. But for many hazardous waste, such as radioactive waste, there are no completely safe disposal methods.

Much hazardous waste has been dumped in landfills or stored in surface impoundments where leaks have contaminated groundwater and soil. In some cases, such as Love Canal in the United States, public health is threatened. Of the 32,000 potentially dangerous sites in the United States, 1,200 need immediate remedial action -- clean-up costs are estimated at US\$ 100 billion. Thousands of unsatisfactory sites have also been found in The Netherlands, Denmark and Germany.

Q. Are there laws against hazardous waste dumping?

A. Yes, especially in industrialised countries. As these countries tightened their controls over the movement and disposal of hazardous wastes, illegal dumping and traffic has increased.

Q. Where are companies dumping their hazardous wastes?

A. Western companies, hampered by laws against toxic dumping in their own countries, have turned to the Third World and Eastern European countries to get rid of toxic and dangerous wastes. In Western Europe, disposing of hazardous waste can cost up to \$500 per tonne: in Africa it can be as cheap as \$3 per tonne.

Parts of the South Pacific and the Caribbean have long been dumping grounds for toxic wastes. When these sites began to fill up in the 1980's, Africa became the alternative dumping ground. What has complicated the problem is that a number of impoverished West African countries have been lured by the prospect of the payment of millions of dollars to agree to become the dumping ground for millions of tonnes of waste from the industrialised West.

Prior to 1989, the economic and political barriers between East and West created a *de facto* ban on waste trade between the regions. However, almost immediately following the collapse of the Berlin Wall, there were reports of Western hazardous waste heading for Russia, Poland, Romania, Hungary and other Eastern states.

Q. What stand does the World Health Organization, the United Nations Environment Programme and other International bodies take as regards hazardous waste dumping?

A. The World Health Organization (WHO) has sharply criticised the practice of dumping hazardous wastes. Although the wastes are considered too dangerous to bury in the countries of

origin, a very strange twist of logic makes the same waste not dangerous for the Third World and Eastern Europe.

In the late 1980's, the United Nations Environment Programme took action by drafting the Basel Convention on the Control of Transboundary Movement of Hazardous Wastes and their Disposal. The aim of this Convention was to impose strict controls on the international movement of hazardous wastes and eventually reduce their production. (For more information, see The Basel Convention on page 14.) The Basel Convention came into force in May 1992, but there was a growing recognition that the treaty did little to halt toxic trade. In late 1992, the then UNEP Director, Mostafa Tolba, called for a complete ban on waste shipments to developing countries and Eastern Europe.

Many developing nations have long supported a complete ban on the export of hazardous wastes. Some have taken active steps to prevent the dumping - either legal or illegal - of hazardous wastes in their countries. For example, members of the Organization for African Unity (OAU) have set up a 'Dumpwatch' body for this specific purpose.

Today, several industrialised nations support a complete ban on toxic waste trade although seven heavily industrialised countries -- Australia, Canada, Finland, Germany, Japan, the United Kingdom and the U.S.A. -- oppose such a restriction. Not surprisingly, these countries are the source of the majority of the world's waste exports.

Q. What is the best solution for dealing with hazardous waste?

A. There is no safe method yet invented for hazardous waste disposal. All waste disposal facilities release poison into our most precious resources: air, water and earth. No landfill or incinerator is completely safe -- despite the industrialised world's reliance on these technologies. The long-term solutions lie in reducing the amount of waste generated, and transforming an increasing amount of hazardous waste into resources for use and reuse.

Class/Group Activities

1. Have students find words in the text above that mean:
 - (a) can easily catch fire;
 - (b) can explode;
 - (c) can eat away metal containers, skin and other materials;
 - (d) can harm or kill when eaten or absorbed by a living thing.(answers: inflammable, reactive, corrosive, poisonous)
2. Have a class discussion on the dumping of hazardous wastes in Third World countries. Start the discussion by asking, "Is it right to dump hazardous wastes in countries with less strict dumping laws? Whose responsibility is it to protect the people and environment in these countries?" Discuss with the students what action should be taken by the various parties involved, and have them write letters that set out their suggestions.
3. For older students: Have students form groups to investigate in-depth some of the controversies concerning toxic waste. Some examples are the presence of dioxin in paper products or the proposed methods of disposing of nuclear wastes. Have each group prepare a chart listing the pros and cons of each side, and gather newspaper clippings related to both sides of the issue.

Bike and Bike Products

SOURCE

The following activity is adapted from: *A-Way With Waste*, curriculum material produced by Washington State Department of Ecology, USA. The activity may be reprinted for non-profit, educational purposes in Low Income Countries. If reproduced, please credit *A-Way With Waste*, Washington State Department of Ecology, 300 Desmond Drive SE, P.O.Box 47600, Olympia, WA 98504-7600, U.S.A.

This curriculum is written and organised to present integrated waste management concepts affecting land, air and water in the ecosystem. The activities for students aged 5 to 18 years, are designed to promote awareness, attitudes and actions to solve waste management problems at home, in school and in the community.

SUGGESTIONS FOR USE

Teachers: As an activity to increase awareness of hazardous waste and how it can be created even in the manufacture of innocuous products.

Sometimes making the things we want creates things we don't want, such as hazardous waste. In the following exercise, students will learn what the term, "hazardous waste" means, and will learn about some of the hazardous wastes created in the manufacturing of a bicycle.

School Subject: Science, Social Studies

Student age: 8-11 years old

Teaching time: 1 hour

Materials: * a bicycle

* Copy of sheet with diagram "Bicycle materials, wastes and by-products" (see next page)

Background

Hazardous means dangerous. Hazardous wastes are likely to cause harm to the environment or to humans because they are toxic (poisonous), inflammable (ignitable, highly burnable), reactive (explosive), or corrosive (substances that rapidly eat into and/or dissolve what they touch).

Procedure

1. **Ask the class:** How many of your families own a bicycle? What are the bikes made of? What are the frames made of? How about the tyres? The handle bar grips? Where are the metal, rubber and plastic that go into bicycles made? (In mills and factories that transform raw materials such as petroleum, bauxite and iron ore into bicycle components.)

Ask: What colour is the bike in each of your households? Whose bike is shiny? What is the shiny metal on bikes called? (chrome)

Ask: Which natural resources are used in the making of bikes? (iron; petroleum for plastics, synthetic fibres and synthetic rubber; petroleum distillates for paint and paint solvents; bauxite for aluminium; chrome; coal for coke to smelt the iron or into steel and

others.)

Ask: What had to happen to the natural resources before they could be used to build your family's bike? (They had to be processed in factories.) Direct the discussion from here with the aim of having students realise that when natural raw materials are processed, by-products and waste, some of which may be harmful, are produced.

Ask: What are by-products? For example, what by-products are produced when you burn wood and paper in your stove at home? Are some of these by-products harmful? What kinds of things would have been by-products when your family's bike was made?

2. Fix the sheet with the diagram, "Bicycle materials, wastes and by-products" onto the blackboard, and let the class gather round to view it. If possible, have a student whose family owns a bicycle bring it to the class. Guide students in identifying the bike's component materials (steel, synthetic rubber, plastic, chrome, synthetic fibres (if any), leather (if any), chrome, plastic, aluminium, paint, etc.) Then, by referring to the diagram, point out some of the by-products and wastes resulting from the manufacture of these components.

3. **Explain:** Some (not all!) of the by-products and wastes from making a bike are hazardous. What does hazardous mean? **Ask:** Does this mean that you will get sick from handling or riding the bike? Why not? What happens to the hazardous by-products and wastes produced when the bike was made? (Note: some are captured and recycled for industrial use. Some are captured and disposed of in hazardous waste disposal sites. Some escape into the air and water, some are sent to landfills, and some are dumped illegally.)

Ask: How should hazardous wastes and by-products be managed? Why is it important to use great care in disposing of these wastes and by-products?

Ask: Because hazardous wastes and by-products are made when bikes are built, should we stop making bikes? What should we do that makes more sense? What are some other things you use that might also have produced hazardous products when they were made?

4. **Discuss:** Has there been any news about hazardous waste lately?

Bicycle materials, wastes and by-products

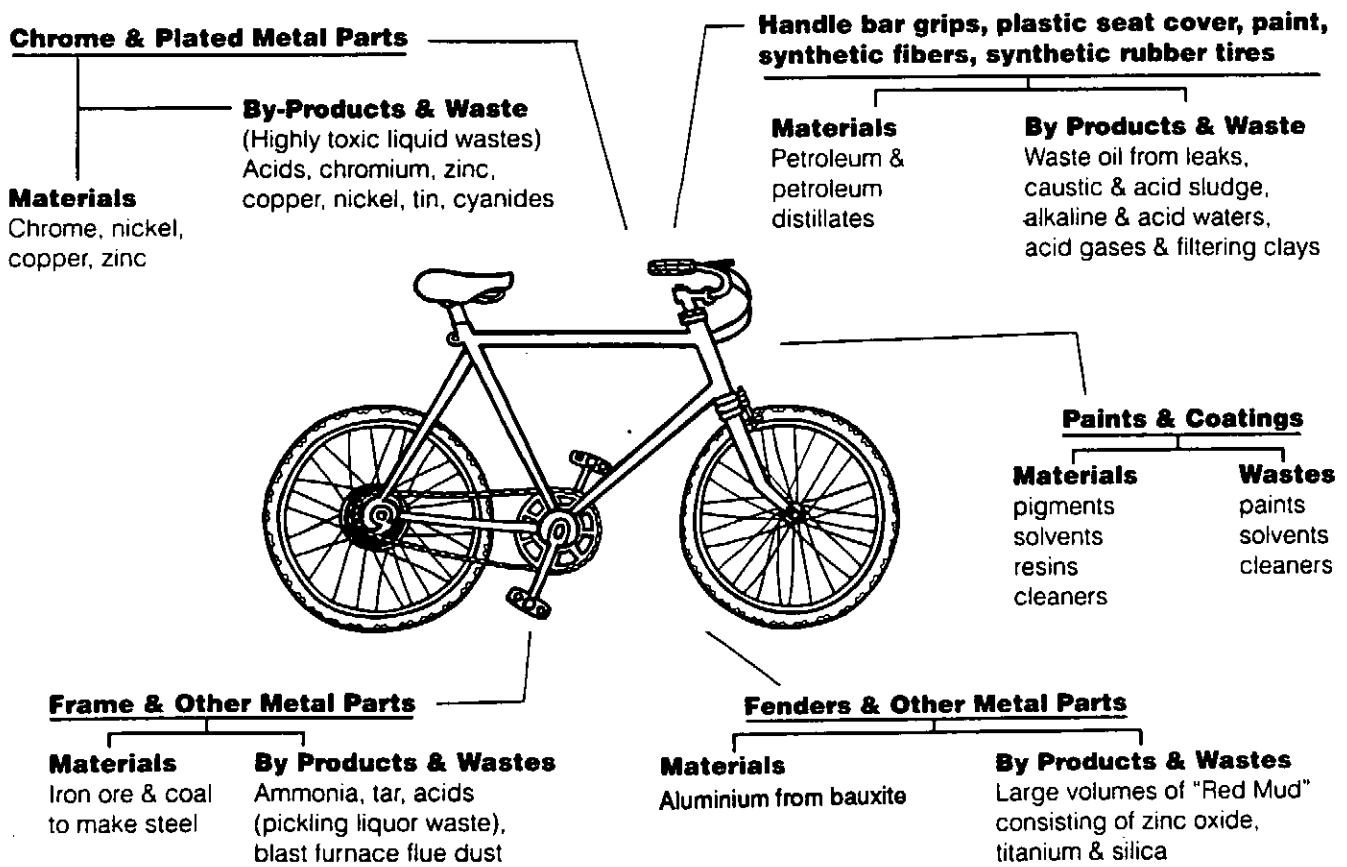

By-product and waste information from *Liquid Waste of Industry* by Nelson L. Nemerow, (Addison-Wesley Pub. Co., Menlo Park, California, CA, 1971)

SOURCE

Panos Features, produced and distributed by the Panos Institute, 9 White Lion Street, London N1 9PD, United Kingdom. If reproduced, please credit original source.

SUGGESTIONS FOR USE

Teachers, Community workers: As a source for class/group discussions.
Journalists, radio broadcasters: In articles and programmes that are reporting on hazardous waste issues. The text could also be used a starting point for a radio discussion (either between experts or between listeners and a radio host using interactive radio).

European waste wraps Pakistani sweets

by Beena Sarwar, Features Editor of the Frontier Post

LAHORE, PAKISTAN: When seven-year old Rizwan developed swollen lips and a painful rash in his throat, a chocolate bar was not identified as the cause. But the allergic reaction came not from the chocolate itself, but from ink on the wrapping paper which came off the chocolate. The sweet had been locally manufactured, but was wrapped in paper imported as scrap from Germany.

Plastic and metallised wrapping paper can be declared substandard and not permitted for use on food in Europe for many reasons. For example, the layers may not join properly or there may have been inadequate moisture or bacteria control. Most European countries ban the export of such scrap, and say it should be destroyed or recycled.

But a change in Pakistani regulations two years ago to encourage free trade allows such

substandard wrappers to be imported as scrap. And some European firms prefer to sell plastic waste at a profit rather than to pay to incinerate it at home. On October 1, 1992, German environment officials confiscated a 1,200 tonne shipment of plastic scrap being smuggled to India.

The profits are high. A Pakistani importer can buy a tonne of plastic scrap for as little as US\$ 100 and sell it to local manufacturers for 10 times as much. The scrap is used to package not only food but also medicines. Lahore businessman, Yasin Pehlwan, said he recently sold five tonnes of scrap metallised paper to a local medicine factory to pack oral rehydration salts.

Mian Yunis, a Pakistani printer, says that "plastic scrap from Sweden, Denmark, France and Austria is pooled in the Netherlands and exported to

developing countries. The European are happy to be rid of their problem, and we are happy to get cheaper materials as good as new." He claims the imported scrap material is better than new wrappings produced locally.

But Dr. Sadiq of the Council for Scientific and Industrial Research's Environmental Protection Agency warns that if tin, lead and aluminium in the metallised paper come off and contaminate food, they can affect the brain and cause pain in the joints. Colours used in printing plastic can be carcinogenic, he says.

The use of scrap wrappers was exposed by Khalid Hussain, a reporter with the Lahore-based *The Friday Times*. He names Britain, France, Germany, Switzerland, the Netherlands, Sweden, Denmark and the United States as the main illegal exporters of plastic scrap.

Source: Panos Features (March 1993).

Indonesia's scavengers seek ban on waste imports

by Dewi Sartika, Panos correspondent in Jakarta

JAKARTA, INDONESIA: Indonesia's scavengers, hailed by President Suharto as the country's 'independent troops' for their city cleaning and recycling work, are now asking him to ban waste imports which they say are threatening their livelihoods.

Five of the independent waste-collectors, representing more than 900 scavengers working on paper

and plastic collection points in Jakarta, recently took their complaint to the House of Representatives. They say that imported waste is undermining the prices paid for material they collect. "We now have piles of plastic nobody wants," one said.

The scavengers trace the problem back to 1988, the year Suharto paid tribute to them.

"When the president called us the 'independent troops', our status rose in society's eyes," they say in their appeal. "Many entrepreneurs came to help us with capital so that we could better organise our business.

"Unfortunately, they also learnt that there is money to be made from trash. So these 'tie-wearing scavengers' with large amounts of

capital began to embark on the waste business by importing waste whose chemical contents are not even known."

One Jakarta scavenger, Kusnadi, says that recycling plants now only want the imported waste. They reject locally gathered materials, claiming it is soiled, moist or not usable for other reasons. As a result, scavengers who were earning US\$ 3 a day are now lucky to make half that amount.

The Environmental Impact Control Agency (Bapedal) has also called for a ban on all waste

imports, adding that some of the imported plastic contains toxic residues.

In November 1992, the Trade Ministry issued a decree banning some plastic waste imports. But it stopped short of the total ban sought both by Bapedal and the Population and Environment Ministry, saying that not all waste is useless and that imports simply need to be properly regulated.

Some waste shipments were already on their way before the partial ban became widely known. For example, at least 18 containers

valued at US\$ 80,000 left the United States for Indonesia in the week of the decree. Though these have now arrived, many have not been collected, posing a further problem and expense for the government in arranging their disposal.

While this dilemma is being resolved, the scavengers are struggling to survive. "We do not want money and capital," says Kusnadi. "We want the president to stop the waste imports."

Source: Panos Features (April 1993).

ACTIVITY

Hazardous waste on the Mexico-US border

SOURCE

"Reconciling Trade and the Environment" by Hilary F. French, in *State of the World 1993: A Worldwatch Institute Report on the Progress Toward a Sustainable Society* (W.W. Norton & Co., Inc. New York/London), and "Trashing out Third World Neighbours" by Karen E. Klein and Stephen A. Scauzillo in *World Vision* (Dec.1991/Jan.1992). If reproduced, please credit original sources.

SUGGESTIONS FOR USE

Teachers, Community workers: As a class/group exercise to encourage awareness of problems associated with hazardous waste.

Radio broadcasters: The text could be used as a starting point for a radio discussion (either between experts or between listeners and a radio host using interactive radio).

Use the information below to prepare a news article on the hazardous waste situation on the Mexico-US border. Perhaps, you can do further research on the topic before writing the article. Think of an attention-seeking heading. Use the news briefs above, for ideas on how to set out the facts.

- * The border region between the United States and Mexico is home to nearly 2,000 manufacturing plants known as *maquiladoras* - branches of companies that are allowed to import duty-free components for processing in Mexico on the condition the final product is exported back. Almost all the plants are foreign-owned, drawn there by wages as low as 7 per cent of what is paid for comparable work in the United States, as well as by the preferential tariff treatment and proximity to markets.
- * Frequent toxic spills plague the modern factories that are built smack against *colonias*, densely-packed neighbourhoods where workers and their families live in shacks without running water or electricity.
- * Investigations by a number of groups have revealed alarming conditions in the border area. At three-quarters of the *maquiladoras* sampled in 1991, the U.S. National Toxic Campaign found toxic discharges, including chemicals that cause cancer, birth defects and brain damage, being emptied into open ditches running through settlements near the factories.
- * The American Medical Association describes the border area as "a virtual cesspool and breeding ground for infectious diseases," in no small measure due to the fact that the population there has swelled to twice its former size in the last two decades, while sewage treatment remains practically nonexistent.
- * Investigations by medical teams on both sides of the border have revealed alarming public health conditions, including elevated rates of hepatitis A and tuberculosis, in part because some of the pollution drifts or flows back and forth across the national boundary.

- * In theory, Mexico's environmental laws are roughly comparable, and in some cases stricter than those of the U.S., but enforcement has been lax.
- * An official with Mexico's environment ministry estimated that in 1991 only 35 per cent of the U.S.-owned factories along the border complied with Mexican toxic waste laws. Though maquiladoras are required to return to the United States any waste they generate, compliance with this mandate is believed to be the exception rather than the rule.
- * Mexico has announced its intention to tighten enforcement of its environmental laws.

Plastics: Trashing the Third World

by Anne Leonard

SOURCE

Multinational Monitor, June 1992.
If reproduced, please give credit to original source.

SUGGESTIONS FOR USE

Teachers: As background information for classroom discussion on international movement of waste.

NGOs: As background material for campaigns on waste dumping.

Journalists, Radio broadcasters: As a source of information for articles/programmes on international movement of waste.

JAKARTA, INDONESIA — In the 90 degree heat, women stand over huge piles of plastic garbage. It is too hot to wear a protective smock — not that one is available anyway. They use the same bare hands to wipe the sweat from their brows that they use to sort the thousands and thousands of old plastic bags.

Even though the women are working in a crowded slum outside Indonesia's largest city, much of the writing on the plastic garbage is in English. The women sort through liquid soap bottles, food wrappers, disposable diaper packages and huge bags with familiar logos — Dow, Du Pont, Monsanto, Solvay, BASF, Mobil. A white powder blows out of some of these bags as the women pull them from the pile. The women sorting the bags cannot read English, so they do not know that the white powder is titanium dioxide, which causes respiratory damage. They do know, however, that when the Indonesian plastics recycling companies they work for began importing plastic waste from the United States, they developed skin rashes they never had when they only processed locally produced plastic waste.

The health risks faced by the Indonesian women — and thousands like them throughout Asia and elsewhere in the Third World — are a direct result of the upsurge in plastic use in the United States — and of industry efforts to quell public concern in the United States about the environmental effects of increased plastics use.

Plastic's new image — biodegradable and recyclable

In 1989, U.S. corporations used more than 12 billion pounds of plastic for packaging designed to be thrown away as soon as the package is opened. In the 1990s, this figure is expected to double.

It was not until recently, when people began to

realize that landfilling plastic preserves it forever and burning it releases some of the most toxic substances known to science, that the U.S. public started to question the country's growing dependence on plastics. Rather than address these serious environmental problems, the plastics industry focused its attention on addressing its public image.

A confidential December 22, 1989 letter from Larry Thomas, president of The Society of the Plastics Industry, invited plastics manufacturers to help develop a \$150 million public relations campaign. "The image of plastics among consumers is deteriorating at an alarmingly fast pace. Opinion research experts tell us that it has plummeted so far and so fast, in fact, that we are approaching a 'point of no return,'" Thomas wrote. "Public opinion polls during the 1980s show that an increasing percentage of the general public believes plastics are harmful to health and the environment. That percentage rose sharply from 56 percent in 1988 to 72 percent in 1989. At this point we will soon reach a point from which it will be impossible to recover our credibility. (Witness what has happened to the nuclear energy industry.)"

The plastics industry developed a two-point plan to restore its image. First, by mixing small amounts of corn starch into plastic products, the industry claimed its plastic packaging, garbage bags and diapers were "biodegradable." It did not take long for the U.S. public to figure out that although corn biodegrades, plastic does not [see "The Biodegradable Myth," *Multinational Monitor*, March 1990].

Next, the industry jumped aboard the recycling bandwagon. Instead of "biodegradable," nearly every plastic package on the supermarket shelf is now stamped "recyclable."

"If we can get our act together and show the world just how recyclable these valuable polymers are and

Anne Leonard is a waste trade campaigner with Greenpeace.

Plastic Waste Exports from the U.S. to Asia

January Through May 1992

Country	Shipments	Tons
Bangladesh	1	54.45
China	15	930.74
Hong Kong	1,215	39,194.46
India	34	2,266.79
Indonesia	101	4,974.04
Japan	14	152.53
Korea	13	225.78
Malaysia	11	696.74
Pakistan	5	112.60
Philippines	140	6,419.86
Singapore	5	78.68
Sri Lanka	6	177.34
Taiwan	7	179.97
Thailand	10	254.80
Total	1,577	55,718.78

(Source: Port Import/Export Research Service Records, January-May 1992.)

Plastic waste is seldom if ever recycled into the same product, so recycling used plastic does not make a dent in the amount of plastic needed to make the original products. Additionally, each time plastic is heated, its chemical composition changes and its quality decreases, so the number of times it can be recycled is very limited. The most dishonest aspect of plastic recycling claims, however, may be that many of the plastic bags and bottles dropped off at local recycling centers in the United States are shipped to Indonesia and other Third World countries, where much of it is not recycled at all.

Plastic waste exports

The plastics industry is now adopting the tried-and-true practices of international waste traders worldwide. By exporting their wastes to less-industrialized countries, U.S. plastics corporations have learned, they can avoid domestic regulations and community opposition to waste-handling facilities, and pay their workers wages far below U.S. levels.

It is increasingly likely that the plastic bags and bottles dropped off at a local recycling center in the United States will end up in the countryside in China or in an illegal waste importer's shop in Manila.

Last year alone, over 200 million pounds of plastic waste were exported from the United States, according to data from Port Import/Export Research Service. This

that the industry stands behind the commitment to prove it, then the mathematics will change," explained Marty Forman, chair of the Institute of Scrap Recycling Industries' plastic committee last June. "It won't be a 60-billion-pound market shrinking to 45 because 15 billion pounds were recycled, it will be an 80 or 90 or 100 billion pound market which has expanded because those plastics are recycled."

Unfortunately, the plastics companies' claims that their plastic is "recyclable" are badly misleading.

waste was sent to Argentina, Brazil, Chile, China, the Dominican Republic, Ghana, Ecuador, Guatemala, Hong Kong, Hungary, India, Indonesia, Israel, Jamaica, South Korea, Malaysia, Morocco, Nigeria, Pakistan, the Philippines, Russia, Singapore, South Africa, Taiwan, Tanzania, Thailand, and Trinidad and Tobago.

The primary target of U.S. plastic waste exporters is Asia. In 1991, more than 15 million pounds of plastic waste were shipped to the Philippines, 35 million pounds to Indonesia and over 75 million pounds to Hong Kong (much of which was sent on to China).

Industry recycling coalitions tout exports for diverting waste from diminishing U.S. landfill capacity while providing much needed employment in less-industrialized countries. In a September 1991 issue of *Plastics News*, Gretchen Brewer, a consultant with Earth Circle in La Jolla, California, justified plastic waste exports to Asia because "they have an urgent need to employ a lot of people, and it also helps them get more raw materials."

The U.S. Chamber of Commerce also denies that there are any problems with plastic waste exports. Harvey Alter, manager of the Chamber's Resources Policy Department, testified last fall in a Congressional hearing on the subject. "There is no basis," he assured lawmakers, "for accusations that the United States is 'dumping' hazardous (or other waste) on unsuspecting developing countries. Materials for recycling, virtually by definition, are sold to enterprises in countries with sophisticated manufacturing facilities."

Since there are no federal oversight mechanisms or standards for plastic waste exports, no one really knows what happens to the millions of pounds exported annually. Harrie Cohen, chief executive officer of Ontario Plastics Recycling in California, admits that he sends all of the plastic collected by his firm to China. "I don't know exactly what they're doing with it," he told a *Plastics News* reporter last year. Apparently, the U.S. "cradle to grave" approach to waste management, which requires tracking and monitoring at all stages from waste production to transport to disposal, does not apply if the grave is in another country.

A Greenpeace investigation of "recycling" facilities in Asia reveals that plastic waste is being shipped to countries which ban waste imports, that recycling facilities are endangering workers and the surrounding environment and that much of the plastic sent to be recycled is simply dumped in landfills or in random locations.

Answer to Puzzle: A Junk Trap! (shown on the next page): A mouse. The animal probably crawled into the old bottle looking for food, or just out of curiosity. When an animal falls to the bottom of a glass bottle, it often can't climb up the slippery sides. So it is likely to end up starving to death.

Can you think of other trash that might harm wildlife?

A Junk Trap!

SOURCE
OUTREACH

SUGGESTIONS FOR USE

Children's newspaper supplement/magazine editors: To use/adapt the puzzle to complement other activities/articles on threats to wildlife or on waste issues.

Something has fallen into this old bottle and cannot get out.
Join the dots to find out what it is.

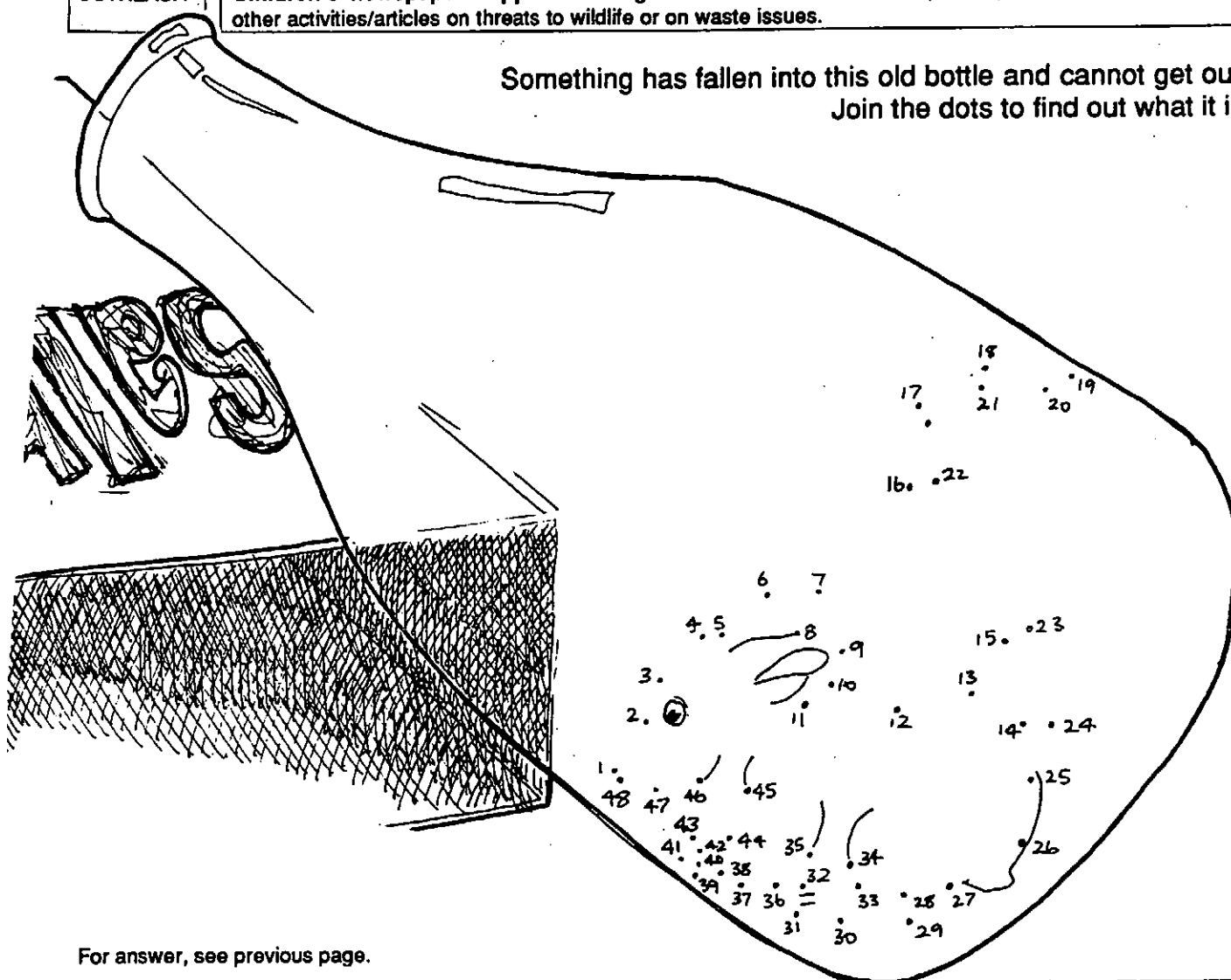

For answer, see previous page.

ARTICLE

Deadly Litter Chokes Livestock

SOURCE

Adapted from an article of the same name by A.Y.Artan in *Panoscope* No. 36 (July 1993), published by the Panos Institute, 9 White Lion Street, London N1 9PD, United Kingdom.

The material can be republished free of charge in developing countries with attribution to Panos.

SUGGESTIONS FOR USE

Teachers: As background information for discussions on hazardous waste.

Journalists, Radio broadcasters: Use in articles/programmes to increase awareness of the dangers of waste to living things

In recent years Somalia has devastated by war and famine. Now the country is facing a

new threat from a man-made pollutant that is killing livestock. Light-weight plastic bags are

strewn around many desert areas and pasture lands, to the dismay of nomads and farmers.

The cheap and handy bags, imported from Europe and Saudi Arabia, are used by millions of people to carry food, liquids and other items. They have largely replaced locally-produced baskets. However, the bags do not last long, and are often carelessly thrown away. The wind blows them around until they get caught in trees, bushes and dry grass.

Bits of torn plastic of all colours now litter Somali towns, and are also spreading deep into

the countryside, where they are a growing cause of death among animals. The animals eat the plastic along with the grass and leaves that have trapped the bags. Distraught nomads have examined their dead livestock, and found plastic blocking up the animals' intestines.

There is no sign of an end to this problem, as more and more bags are being imported. Few people realise the dangers of carelessly discarding the plastic--that it threatens to upset the precarious balance of nature in a country struggling to recover from other, bigger crises.

FICTION

Adventures of RANGER RICK

Rick and the gang learn about a trashy problem by Kathy Walsh; drawings by Alton Langford

SOURCE

Reprinted from the September 1990 issue of *Ranger Rick* magazine, with permission of the publisher, the National Wildlife Federation. Copyright 1990 by National Wildlife Federation. For further information, please contact: The Editor, *Ranger Rick*, National Wildlife Federation, 1400 Sixteenth Street, NW, Washington, D.C. 20036-2266, U.S.A.

SUGGESTIONS FOR USE

Teachers, Community workers: As a story to read to the class/youth group prior to discussion.
Radio broadcasters: As a story to read over the air.
Children's newspaper supplement/magazine editors: To adapt/reprint (Copyright permission would have to be sought from NWF.)

Scarlett Fox gazed out at the gleaming ocean. She, Ranger Rick Raccoon, and Boomer Badger were sailing along in a homemade boat.

"Now I know what they mean by 'sea to shining sea'," she said, watching the afternoon sun reflect off the water. "The ocean certainly is beautiful."

"Aye, that it is, matey," Boomer agreed in a growly voice. He had been talking pirate talk since they'd started their trip early that morning. He was dressed like a pirate, with an earring in one ear and a patch over one eye. And he'd hung a pirate flag with a skull and crossbones from the mast of the boat.

Rick was frowning. "Well, the ocean would be *more* beautiful if there weren't so much trash floating in it," he said. He watched as a plastic bottle went bobbing by. The friends had heard that trash in the ocean was a big problem. So they had decided to take this trip and check it out for themselves. They'd been amazed at the amount of trash they'd seen so far.

Right now, Boomer was peering across the water looking for ships to "attack." Suddenly he called out, "Well, blow me down! Sea turtle

ahead, mates."

The badger cupped his paws around his mouth. "Ahoy there, turtle!" he shouted.

The turtle answered with a frantic cry. "Help! Help me!"

Now the friends could see that the turtle was struggling. Tangled tightly around its neck and front flippers was a bunch of plastic netting.

"Oh, my gosh!" exclaimed Scarlett. She grabbed the life preserver and tossed it near the turtle. The turtle managed to grab onto it with its beak. Then, Rick, Scarlett and Boomer pulled the tangled turtle to the side of the boat. And with a big *heave, ho!* they hauled it aboard.

Rick rushed to the first-aid kit they'd brought along and got out some scissors. He carefully cut the turtle free from the netting. Then, Scarlett put some ointment on the turtle's flippers where the plastic had cut into them.

"Oh, thank you," gasped the exhausted animal. "That netting was so tight around me I couldn't get out of it. I've been struggling for days now, and I was just about worn out. If you hadn't come along, I would have drowned."

Then the turtle collapsed, panting heavily with its head lying on the bottom of the boat.

After the turtle had some time to rest and regain its strength, Rick introduced himself and his friends.

"I'm Simon Sea Turtle," the turtle said. "I sure am glad I ran into you folks."

"Simon," Scarlett said, "how did you get

tangled up in all that netting?"

"Well, it wasn't very hard," the turtle said bitterly. "There are tons of trash in the ocean. Lots of it has been dumped into the water from ships. Far out to sea, big ships do the dumping. And closer to shore, people in small boats toss junk out, too."

"If anybody on *my* ship ever did that," growled



Boomer the pirate, "I'd make them walk the plank!"

"Yeah, and let 'em get tangled up in their own trash," agreed Simon. He shook his head sadly. "The worst thing is that most of the trash in the ocean is made of plastic, like plastic packaging and bags. And plastic can take hundreds of years to break down and disappear!

"Also, there's the problem of plastic fishing nets. Each night, fishermen put so much plastic netting in the water that it could stretch across the United States more than 10 times! Sometimes nets break loose and get lost. All this plastic floating around is causing an awful lot of trouble for a lot of animals," Simon said sadly.

"But there is some good news," Rick said to Simon. "People have passed a law that makes it illegal for ships to dump trash overboard, at least in some areas."

"Aye, that is good news, mateys," said Boomer the Pirate. Suddenly Boomer saw something that made him forget to be a pirate. He let out a loud scream. "Aaaagghh!"

The animals all turned to where Boomer was pointing. They froze at what they saw. A huge ship was heading for them at top speed!

"They must not see us!" cried Scarlett frantically. Boomer began trying to dig a hole in the bottom of the boat. Simon wished he could pull his body inside his shell the way land turtles can.

The big ship rushed towards the small boat, pushing a huge wave ahead of it. Just as the ship's bow was about to hit, the wave lifted the little boat up, up and up. Then suddenly it shot down the other side of the wave like a surfboard. Rick, Scarlett, Boomer and Simon held onto anything they could to keep from falling overboard. Finally the little boat came to rest a short distance from the ship.

Boomer turned and shook his furry fist at the big ship, which was almost past them now. But just as he began to shout, "I'll have your captain clapped in irons!" a soda can landed right in his

mouth. Then all sorts of other trash--cardboard boxes, plastic bags, wooden crates, bottles and other things--rained down from the big ship. Most of it landed in the water, missing the animals' boat.

Boomer disgustedly spit the soda can out of his mouth. "Hey, Rick," he said with a splutter, "I thought you said there were laws against dumping trash."

"Well, there are, Boomer," Rick said. "Some people are following them. But not everyone. And it's hard to make sure that they do."

"Yeah, it's a big ocean," Simon agreed, looking over the water. Then he gasped. "Hey! That's one of my sea turtle friends out there. Oh, no! She's about to eat that floating plastic bag!"

Before the others realized what had happened, Simon had scrambled over the side of the boat and was heading towards the other turtle. Just as the turtle was about to gulp down the plastic bag, Simon swam up and swatted the bag away with his flipper. He and his startled friend talked excitedly for a minute. Then the turtle patted Simon on the shell with her flipper and swam off.

"What was that all about, Simon?" Rick asked when the turtle had swum back to the side of the boat.

"That was my friend, Selma," Simon explained. "She was about to make a mistake lots of sea turtles make. A floating plastic bag looks a lot like a jellyfish, one of our favourite foods. Many turtles eat the bags and die. Luckily, I haven't been fooled--at least not yet." Then he sighed. "Well, I guess I'd better be off. Thank you again for rescuing me."

"Goodbye, Simon," the animals called. They waved as he began swimming off.

"You know," Scarlett said to her friends, "we were here to help this time, but if there ever is a next time..."

They stood silently, watching the turtle paddle away.

"I hope he'll be okay," Rick said after a while.

Scarlett and Boomer nodded. "Aye, matey," Boomer said quietly.

Kids: Many kinds of wildlife--including sea birds, seals, sea lions, whales and sea turtles--mistake plastic waste for food or get tangled up in it. This can hurt or even kill them. Some trash that's been dumped into the ocean eventually washes up onto beaches. There it can be a danger to other animals and to people--or just make a big mess. That's where you can help. Many organizations hold beach clean-ups. Here are two organizations that can help you find out about a clean-up near your home (or how to organize a clean-up yourself): (1) Children's Alliance for Protection of the Environment (CAPE), P.O.Box 307, Austin, Texas 78767, U.S.A. (2) Clean Up The World, 123 Harris Street, Pyrmont, Sydney NSW 2009, AUSTRALIA

The Basel Convention

SOURCE

"Basel Convention Now In Force" in *Greenpeace Toxic Trade Update* No. 5.2 (second quarter, 1992); "Basel 'Dumping' Convention Still Legalizes Toxic Terrorism" by Jim Vallette in *Greenpeace Toxic Trade Update* No. 6.1 (first quarter, 1993); "Basel -- Another Dumping Convention?" a political analysis by Jim Puckett in *Greenpeace Toxic Trade Update* No. 6.4. If this article is reproduced, please credit original sources.

Greenpeace Toxic Trade Update is published quarterly (in English, French and Spanish) by the Greenpeace Toxic Trade Campaign. The Greenpeace Toxic Trade Campaign seeks an end to the international trade in toxic wastes, toxic products and toxic technologies. Each issue of *Greenpeace Toxic Trade Update* presents articles on international legislative developments relating to toxic trade, schemes and proposals to export toxics around the world, grassroots movements to prohibit toxic trade, and recent literature on the international trade in toxic wastes, products and technologies. For further information, contact Greenpeace Toxic Trade Campaign, 1436 U Street NW, Washington, DC 20009, USA.

SUGGESTIONS FOR USE

Teachers: Use in class discussions/ activities on problem-solving environmental issues, and on hazardous waste issues

Community workers, NGOs: As background information for activists involved in local or national toxic waste dumping campaigns.

Journalists, radio broadcasters: As background 'awareness' material for articles/programmes concerned with local waste dumping issues.

In the late 1980's, the Basel Convention on the Control of Transboundary Movement of Hazardous Wastes and their Disposal was drafted by the United Nations Environment Programme (UNEP).

The Convention entered into force on 5 May, 1992. Its target is to impose strict controls on the international movement of hazardous wastes and eventually to reduce their production. It regulates trade by a procedure called "Prior Informed Consent" (PIC). This requires exporters to notify the recipient nation of a shipment and to receive approval for it before proceeding. The exporter should also ensure that the importer has adequate technical capacities to dispose of waste without harming human health or the environment.

Fifty-five countries are contracting parties to the Basel Convention (February 1994). These countries are: Antigua and Barbuda, Argentina, Australia, Austria, Bahamas, Bahrain, Bangladesh, Belgium, Brazil, Canada, Chile, China, Cyprus, Czech Republic, Ecuador, Egypt, El Salvador, Estonia, Finland, France, Hungary, India, Indonesia, Iran, Japan, Jordan, Kuwait, Latvia, Liechtenstein, Malaysia, Maldives, Mauritius, Mexico, Monaco, Netherlands, Nigeria, Norway, Panama, Peru, Philippines, Poland, Romania, Saudi Arabia, Senegal, Seychelles, Slovakia, Slovenia, St. Lucia, Sri Lanka, Sweden, Switzerland, Syrian Arab Republic, Tanzania, United Arab Emirates and Uruguay.

The Convention disappointed many

environmentalists and people from less industrialised countries who wanted the treaty to totally ban any movement of hazardous wastes, see box 1: Greenpeace denounces ban.

The first meeting of the Basel Convention was held in November 1992 in Uruguay, Dr. Mostafa Tolba, in one of his final acts as executive director of the United Nations Environment Programme (he retired from UNEP at the end of 1992), stunned industrial delegates by proposing a complete ban on waste shipments to developing countries and Eastern Europe.

"The Basel treaty is not a panacea for this global problem that is sometimes described as 'toxic terrorism.' Hazardous wastes will always follow the path of lower costs and lower standards," said Dr. Tolba. "The worrying aspect is the rising number of projects by the industrial world to construct waste-to-energy plants or what are described as 'non-hazardous' waste landfills or incineration facilities in developing countries."

His initiative followed growing awareness that Basel's rules requiring prior notification of waste trade schemes have done little to halt the toxic trade.

At the Uruguay meeting, Dr. Tolba's proposal was supported by many developing countries, but industrialised nations, particularly major waste-exporting nations such as Germany, USA and the United Kingdom, forced a drastic weakening of the proposal. The final resolution simply requested industrialised

Box 1: Greenpeace denounces ban

Greenpeace has denounced the Basel Convention for the following reasons:

1. *It is not a ban.* There are no provisions to ban any kind of waste trade, except to Antarctica. "By providing a legal framework within which to trade waste, the Convention legitimises a practice which should be considered a criminal activity. The Basel Convention's will dangerously create an illusion that the international waste trade is now under control. (article 4)"
2. *It will not prevent waste generation.* When industrial interests can cheaply export their waste problems rather than take responsibility for them at home, there is little incentive for them to reduce the amount of waste produced or turn to the creation of non-polluting industries and environmental-benign products that do not create hazardous waste. (Article 6)
3. *It does not address the "double standards" inherent in waste trade.* This refers to the issue that although the waste is considered too dangerous to bury in the countries of origin, a very strange twist of logic makes the same waste not dangerous for developing countries or countries with less stringent environmental laws, and where environmental monitoring, enforcement, protective equipment, emergency response and health care are lacking.. (Article 6).
4. *Radioactive waste can be interpreted to be excluded from the scope of the Convention.* (Article 1)
5. *Exports to non-parties are allowed.* Agreements and treaties can be made with non-Parties to the Convention whereby waste can be traded so long as these agreements "are not less environmentally sound". The problem is that this condition is somewhat subjective. (Article 11)
6. *Liability provisions.* As yet there are no liability provisions in the agreement. (Article 12)
7. *It does not define waste management as including waste prevention measures.* The Convention defines waste management in a limiting way, excluding all actions that would prevent the generation of wastes (Article 2)

countries to stop disposing hazardous wastes in developing countries, but this "request" exempted exports for "recovery operations". The Basel Convention's definition of "recovery operations" includes such easily abused

methods as "use as a fuel," "land treatment resulting in the benefit to agriculture improvement" and "reuses of previously used oil." Over 90 percent of waste trade schemes targeting developing countries claim some sort

Box 2: Dumping by any other name....

The latest trend in the waste trade industry is to disguise waste trade deals as recycling or reuse proposals. Waste traders tailor their schemes to the particular needs of the place where they would like to dump their wastes.

For example, several Caribbean countries suffer from acute shortages of electricity and roads. Consequently, a host of waste traders are trying to persuade them to build toxic waste incinerators which they claim would produce electricity (along with toxic air emissions and ash) or use the resulting incinerator ash (contaminated by heavy metals and dioxin) to build roads.

Even if recycling schemes involved some form of legitimate recycling, this type of trade represents a dangerous loophole through which huge volumes of poisons can be move across

boundaries. Often, these recycling operations are marginal businesses which would not be allowed in the countries where the waste is produced. And often these "recyclers" leave vast amounts of toxic residues in the importing country.

Heavily industrialised countries ship millions of tonnes of waste to metal smelters in Asia and Latin America for "recycling". The smelters heat the toxic wastes to extract selected metals from imported wastes -- but the wastes commonly contain dangerous levels of toxic heavy metals and chlorinated chemicals which are either released into the air, or remain as incinerator residues which are dumped on land.

In Taiwan, for example, a company called Acme operated a lead smelter which, until 1990, burned used batteries from Japan

and the United States. A local doctor discovered that, of the sixty-four workers at the plant, thirty-one had lead poisoning. Lead emissions were so prevalent that children attending school downwind of Acme had to wear cloth masks over their mouths.

The Thor Chemical mercury smelter in South Africa, which processes mercury wastes from Europe and North America, has discharged extraordinarily high levels of mercury contamination in a nearby stream.

Claiming a recycling pretext is an easy way to disguise economically motivated waste export. Recycling usually implies an environmentally sound activity, but where hazardous wastes are concerned, it is often a very deadly and dirty business.

Source: GREENPEACE: leaflet, 'International Waste Trade' (1991)

of "recycling," "reuse" or "humanitarian" benefit, see box 2: Dumping by any other name..

Faced with inaction and indifference from industrialised waste-exporting countries, developing nations have erected national and regional barriers to toxic waste traders. At least 103 countries have enacted total bans on the import of toxic wastes. African and Central American countries have signed regional accords banning all waste imports, and Latin America, the Mediterranean, Southeast Asia and the Pacific regions are developing similar policies.

While the Basel Convention in its present form does little to stop either the generation of hazardous waste or its transboundary movement, there are signs of hope. There has been a major shift in policy of many rich, industrialised countries regarding waste exports. In the past, Basel Convention meetings have been drawn on lines between the North and South where a handful of industrialised nations have tried to forestall the efforts of developing countries to end waste trade. This polarization between rich and poor countries was finally broken by the Swiss delegation which said it could support a full ban on export of hazardous waste from industrialised OECD (Organization for Economic Cooperation and Development) countries to non-OECD countries (which include developing countries and countries from Eastern Europe).

Other industrialised countries followed the Swiss lead. Today, 13 of the 24 OECD countries support a full ban.

At the end of 1993, seven heavily industrialised countries stand in isolated opposition to a complete ban on the export of hazardous wastes from OECD countries to non-OECD countries. Not surprisingly, these countries -- Australia, Canada, Finland, Germany, Japan, the United Kingdom and the United States -- are the source of the majority of the world's waste exports.

In March 1994, the second full meeting of the Basel Convention will be held in Geneva, Switzerland. This meeting is likely to be a pivotal one. As Greenpeace Toxic Trade Coordinator, Jim Puckett, puts it:

"The question is whether these countries [Australia, Canada, Finland, Germany, Japan, the U.K. and the U.S.A.] will finally yield to overwhelming international opinion in favour of protecting their neighbours in developing and Eastern European countries from toxic waste traffic and dumping? Will they seek to become self-sufficient in waste management through the adoption of clean production methods of manufacture [non-polluting industries making environmentally-benign products that do not create waste], or will they remain lodged in out-moded, consumptive, waste-intensive, and "dump-and-run" policies?"

Basel Convention Class/Group Activities

1. Have the students select one of the following to complete:
"If I were in charge of a chemical factory that produces toxic wastes, I would...."
"If I were the president/prime minister of a country that exports hazardous wastes, I would...."
"If I were the president/prime minister of a country that imports hazardous wastes, I would..."
2. Debate the Basel Convention in class. Make sure divergent viewpoints are considered (e.g. people who create waste, environmentalists, waste exporters, people in whose community waste is being dumped etc.)
3. Have the students find out if toxic wastes have been/are being dumped in your region. What type of wastes are they? Where did the wastes come from? What risks do these wastes present to your community? Brainstorm in class about what the students as private citizens can - and should - do about the dumping of hazardous waste in your community. Have them act upon the suggestions.
4. Older students can research other international treaties concerned with the dumping of waste. (e.g. The Convention on the Prevention of Marine Pollution by Dumping of Wastes and Other Matter (London Dumping Convention), Lomé IV Convention, the Bamako Convention). Find out which nations were party to these treaties, the aims of the treaties, when the treaties were put into force, and how effective the treaties are.
5. Divide the class into small groups, and have each group draw up their own hazardous waste treaty. They must decide their overall goals, and work out how different parties can be encouraged to meet these goals. Have each group present their 'treaty' to the rest of the class, and either have a vote on which 'treaty' the students think is best, or combine the best from the 'treaties' to make a class 'treaty'. Send your 'treaty' to your government and/or the United Nations Environment Programme (via OUTREACH Coordinator, IPA, UNEP, P.O.Box 30552, Nairobi, Kenya).

Keeping Tabs on Toxics

by Daniel Nelson

SOURCE

The following article is reprinted from *Panoscope* No. 34 (January 1993). *Panoscope*, an Environment and Development magazine, is produced six times a year by Panos, an independent institute working to promote sustainable development.

This *Panoscope* material can be republished free of charge in developing countries with attribution to Panos. For further information, contact the Panos Institute, 9 White Lion Street, London N1 9PD, United Kingdom.

SUGGESTIONS FOR USE

Community workers, NGOs: As reference material for local and national toxic waste campaigns, for advising local farmers, factory workers etc.

Health and Environment officials: As reference material for planning decisions or in the event of an accident involving hazardous materials.

Radio broadcasters, journalists: As information for articles/programmes concerned with accidents and campaigns involving hazardous materials.

Mix the world's rapidly growing number of manufactured chemicals with a liberal dose of ignorance about safe handling and disposal and you get a potentially lethal formula. But an International registry in Geneva is providing vital information to countries anxious to know more about the hazards.

For the Pacific islands grouped in the Federated States of Micronesia it was a growing pile of rubbish in a tourist paradise: waste from photographic chemicals.

The government asked the World Health Organization's Regional Centre for the Promotion of Environment planning and Applied Studies in Malaysia how to dispose of the chemical safely. The Centre in turn realised that another cumbersome body, the International Register of Potentially Toxic Chemicals, could provide the answer.

But the Geneva-based Register could not find the information in its library. So staff contacted the US manufacturer by telex, who within two days sent data on the safe handling of the data.

That was one example of how the Register, set up by the United Nations Environment Programme (UNEP) in 1976, can help governments by providing reliable information. It is a useful, potentially life-saving service because, as the organisation points out, "the number of chemicals that any government may need to tackle has become

unmanageable."

There are more than 8 million known natural and manufactured chemicals, of which some 70,000 are in common use, with about 1,000 new ones appearing on the market every year. But director, Jan Huismans notes: "It is not just a question of numbers. In most cases the problem is information: how to get it, how to spread it, and how to make sure it is used properly. The greatest obstacle to our safe use and disposal of chemicals is ignorance."

To overcome ignorance, the Register operates a databank; has helped set up national registers in several countries, including China, India, Brazil; runs a query response service; is building up a network for exchange of information worldwide; and implements the "London Guidelines", which are intended to ensure that the principle of prior informed consent is applied in the international chemical trade. The principle is that chemicals banned and severely restricted for health and environmental reasons should be traded across borders only with the consent of the importing country.

The Register has only eight

professionals to deal with a multi-billion-dollar chemical industry. It looks like a case of a mouse taking on an elephant, but Huismans claims some credit: "I'm not satisfied with what we've been able to achieve, but with limited money we have been able to achieve something recognised in the UN and internationally.

The pressure group Greenpeace rejects an ameliorative "end of pipe clean-up, arguing that the best way forward is to eliminate the use of toxic and hazardous chemicals. But even it recognises the Register's value, particularly now that information is being made available through personal computers.

Jim Puckett, European toxic trade coordinator at Greenpeace headquarters in Amsterdam, says: "It's a starting point. It won't solve all the problems, but it's the kind of database people need. Especially in developing countries, people are crying out for information on what will harm their territories and their people."

One of the barriers to the free flow of information is chemical company secrecy, usually on commercial grounds. For years,

many companies and the U.S. government blocked UN efforts to draw up a list of chemical products that have been banned or restricted in their country of manufacture - information of particular value to developing countries. That list now exists and, according to Puckett, "industry has conceded that information exchange needs to take place, because they see the alternative as an increasing number of prohibitions."

Huisman agrees that there is increasing recognition that certain data, such as impacts on human health and the environment, should not be withheld:

"You can lay your hands on better information now. There are possibilities for making better judgments and for managing risks better than in the past." But he admits that "often data is still not there."

So pressing is the need for such a service that most former Soviet bloc countries are continuing with their efforts, in conjunction with the Register, to set up their own information exchange. Says the Register's Garislav Shkolenok: "Environment is one of those sectors where they don't have too many quarrels because the problems are transboundary and they need to work together."

Environmental inquiries

account for about one-third of the approximately 550 requests a year to the Register for information, legal queries around a quarter, and agricultural chemicals about one-third. A new category, hazardous waste, was added in 1989, reflecting a growing public concern, and about 15 per cent of requests are now in this category.

Problems vary enormously. A request from Somaliland (formerly northern Somalia) sought information on locust-control pesticides, crates of which had been opened and spilled by looters. The danger came not from direct contact with the exposed chemicals, but also from possible contamination of water supplies. In cooperation with the Food and Agriculture Organization, a team was sent to advise on identification, hazards and precautions.

Manufacturers' names and data on the human and environmental impact of diethylene glycol was sent to an Argentinean public health official tackling an outbreak of fatal poisoning from a wrong ingredient in a health tonic.

The Register was also able to tell UNEP executive-director Mostafa Tolba (now retired from UNEP) why the estimated 18 billion diapers thrown away every year in the US had become a

"green" battleground. A dossier was rapidly assembled, explaining corporate attempts to win public support, and profits, by reducing the volume of waste through the use of super-adsorbent materials and compression, by making nappies biodegradable, and producing ones without bleach.

The organisation does not campaign. It says both that "there are no safe chemicals" and that "chemicals have helped extend life expectancy, increase food production and improve our quality of life." A brochure says it was established "to be an essential tool in optimising use of chemicals for human well-being and at the same time to provide a global early warning system of undesirable environmental side-effects." This sounds perilously close to the fatal flaw of the International Atomic Energy Agency, set up to propagate nuclear power rather than to act as neutral monitor.

But Huisman says the Register's information does include evaluations provided by national and independent groups on hazards and impact of listed chemicals: "we draw attention to the existence of such information to those in charge of protecting health, and we also try to assist our users in making the best use of data, as well as to train them in risk assessment."

For further information on the Register, contact:

International Register of Potentially Toxic Chemicals

Palais des Nations, CH-1211 Geneva 10, Switzerland. Phone: 41 22 798 8400; Fax: 41 22 733 2673

CHART

Household Products: Potential Hazards

SOURCES

Adapted from several sources including: *Ranger Rick* magazine April, 1988 published by the National Wildlife Federation, 1400 Sixteenth Street, N.W., Washington, D.C. 20036-2266, USA; *Waste: a hidden resource* published by the Tennessee Valley Authority in cooperation with Western Kentucky University (1987). For more information on Safer Alternatives, see Learning-By-Doing leaflet on Hazardous materials.

SUGGESTIONS FOR USE

Teachers, health workers, radio broadcasters, journalists: Information source for increasing awareness of health hazards of household products; and to encourage the use of safer alternatives.

Chart is shown on next page →

Household Products: Potential Hazards

Here are some household products that are potentially hazardous. The chart describes their harmful effects, how to get rid of them and what to use instead:

PRODUCT	HARMFUL EFFECTS	HOW TO DISPOSE OF THEM	THINGS YOU CAN DO
pesticides including herbicides, fungicides, insecticides	<p>1 (see key below)</p> <ul style="list-style-type: none"> * can be absorbed through the skin and by breathing * cause headaches, nausea, fatigue, tension 	<p>Pesticides need to be disposed of by experts. So check with local health authority or waste utility. A local toxic waste collection day may be organised - or perhaps, your parents/teacher can help you organise one in cooperation with the local authority or a local pesticide distributor. This is the only way to dispose of pesticides. If no information is available, use product completely, or share leftovers with neighbours. Never dilute leftovers and pour onto the ground or in water courses.</p>	<ul style="list-style-type: none"> * Above all keep plants healthy: insects will attack sick, weak, injured or poorly-nourished plants * Handpick offending insects and destroy them. * Use soapy water to kill aphids, mites etc. * Make a garlic spray or use citronella to repel many insects. * Encourage creatures such as birds and toads into the field or garden to help to keep the insect population down. * Sprinkle wood ash on the ground around plants to trap and kill crawling insects.
Paint	<p>1,3, (see key below)</p> <ul style="list-style-type: none"> * can irritate your eyes, skin and lungs * fumes can cause headaches, nausea, respiratory problems 	<p>Check with local health authority or waste utility. A local toxic waste collection day may be organised - or perhaps, your parents/teacher can help you organise one in cooperation with the local authority. If no information is available, use it all up or share leftovers with neighbours. Wrap empty container in lots of newspaper, put it in plastic bag and put it out with trash.</p>	<ul style="list-style-type: none"> * Use latex paints as this eliminates the need to use paint thinners which contain additional toxic chemicals.
Paint removers and other solvents (substances that dissolve something else, e.g. turpentine, degreasers)	<p>1,3 (see key below)</p> <ul style="list-style-type: none"> * short-term: irritate and damage skin, eyes, lungs, cause nausea, poisoning * long-term: cause allergies, nervous system disorders, damage kidneys and lungs 	<p>Check with local health authority or waste utility. A local toxic waste collection day may be organised - or perhaps, your parents/teacher can help you organise one in cooperation with the local authority. If no information is available, use it all up or share leftovers with neighbours. Wrap empty container in lots of newspaper, put in plastic bag and put out with trash.</p>	<p>No substitutes for most solvents. Use solvents with great care. Never transfer solvents to unlabelled containers especially food/drink containers.</p> <p>Instead of paint remover:</p> <ul style="list-style-type: none"> * sand off old paint * never use gasoline as a solvent.
Bleach	<p>1 (see key below)</p>	<ul style="list-style-type: none"> * bleach and its fumes can irritate eyes, skin * chlorine bleach mixed with ammonia creates a deadly gas 	<ul style="list-style-type: none"> * use baking soda mixed in water to make good cleaning solution.
Used oil and car batteries	<p>Used oil - 1, 3; car battery - 1, 4 (see key)</p> <ul style="list-style-type: none"> * Some poisons in used oil may be absorbed through skin * battery acid can burn skin, eyes 	<p>Check with local health authority or waste utility to see if there is an organised local toxic waste collection day. If there is not, perhaps, your parents/teacher can help you organise one in cooperation with the local authority.</p> <p>Oil: Recycle at a car servicing station. Never pour oil onto ground or into water courses</p> <p>Battery: Return batteries to where purchased.</p>	<p>No alternatives available. Wear gloves and goggles when handling.</p> <p>Key: 1 - Toxic 2 - Reactive 3 - Ignitable 4 - Corrosive</p>

What to do with Hazardous Waste

SOURCE OUTREACH

SUGGESTIONS FOR USE

Community workers, NGOs: As information for publicity material or for campaigns to reduce hazardous waste.

Radio broadcasters and newspaper journalists: As material for short messages on hazardous waste reduction.

Here are some steps people can take to reduce the amount of hazardous waste they generate, and to ensure that those wastes are safely stored, handled and disposed of.

- * Use alternative products that are non-hazardous or less hazardous.
- * If you need to use products that contain hazardous material, use only the amount needed, and share leftover material with neighbours who need it, too.
- * Recycle. For example, car service stations may accept used car batteries to recycle.

- * Always *carefully* use, store, and get rid of products containing hazardous materials to prevent accidents. Never store hazardous products in food containers. Keep products containing hazardous materials in their original containers, and never remove labels. This will prevent people from accidentally touching or swallowing the material. Corroding containers, however, should be repackaged and clearly labelled.

NEVER REUSE CONTAINERS OF HAZARDOUS MATERIALS

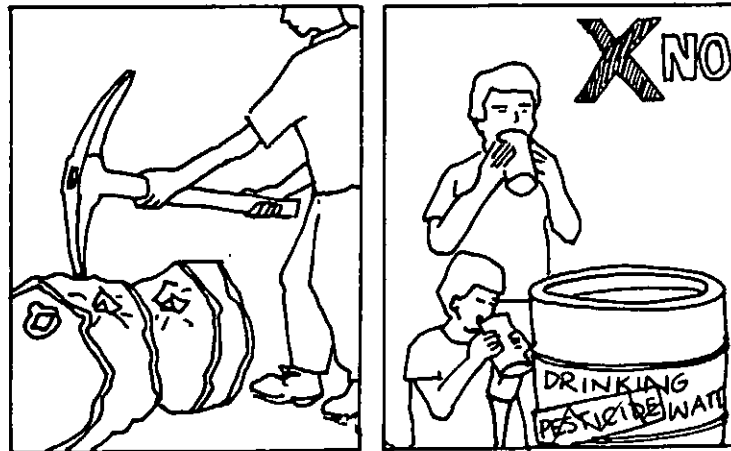

Discarded drums must be made unusable.....
to prevent dangerous misuse.

- * When leftovers remain, never mix household hazardous waste with other household waste. Incompatible substances may react, ignite or explode. Contaminated household waste may become unrecyclable.
- * Follow any instructions on labels for use and disposal of the product.
- * Do not pour hazardous wastes down latrines, drainage channels or onto the ground.
- * Take household hazardous waste to a local collection site, if available.

Odd One Out

**SOURCE
OUTREACH**
SUGGESTIONS FOR USE

Teachers: As an exercise to evaluate students' recognition of hazardous household products.
Children's environment and health magazine/newspaper supplement editors: Include on a puzzle page.

Here are some household products. All except one are hazardous materials. Which is the odd one out?

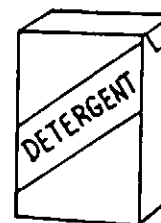
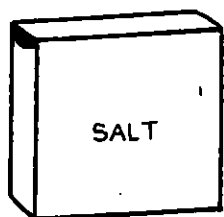

Answer: salt

Use Safer Alternatives to House and Garden "Toxics"

SOURCES

Stepping Lightly on the Earth: Everyone's Guide to Toxics in the Home, leaflet published by Greenpeace, 1436 U Street, NW, Washington, D.C. 20009, USA
A Healthy Environment Starts at Home: A Guide to Safely Dealing with Household Hazardous Waste produced by the Massachusetts Water Resources Authority, 100 First Ave., Charlestown Navy Yard, Boston, MA 02129, USA
The Consumer's Handbook for Reducing Solid Waste produced by United States Environmental Protection Agency (August 1992 - EPA530-K-92-003), 401 M Street, SW, Washington, D.C. 20460 USA
The Guide to Hazardous Products around the Home produced by Households Hazardous Waste Project, 901 S. National, Springfield, MO 65804 USA
School Garden Manual by Marny Smith and June Plecan produced by Save the Children (1989), 54 Wilton Road, Westport, Connecticut 06880, USA

SUGGESTIONS FOR USE

Teachers: As activities for students; as information for students to present in posters, leaflets for the community.
Community workers, radio broadcasters: As information to relay to mothers, farmers etc. through leaflets, meetings, radio messages.

Using non-toxic alternatives to household chemicals will result in a safer home and environment. The safer products are often cheaper, too. Here are some alternatives that you can try:

CLEANERS AND POLISHES
For laundry:

Use soap instead of detergents.

To treat soiled clothes, you can try the following remedies. (Test the remedy on a small piece of

the fabric first, and then wash the clothes after applying the treatment.)

Heavy soils: Rub with a solution of 2 tablespoons (30 ml) baking soda in 1 cup (250 ml) of warm water.

Fruit and wine: Immediately pour salt or hot

water on the stain and soak in milk before washing.

Grease: Pour boiling water on stains and follow with dry baking soda.

Blood: Soak in cold water. For a more stubborn stain, mix cornstarch, talcum powder, or cornmeal with water and apply the mixture. Allow to dry and brush away.

Rust: Saturate with sour milk (or lemon juice) and rub with salt. Place in direct sunlight until dry, then wash.

Mildew: Pour strong soap and salt on the spots and place in sunlight. Keep the spots moist, and repeat as often as necessary.

Scorches: Boil scorched article in 1 cup (250 ml) soap and 2 quarts (litres) milk.

All-purpose cleaners

Mix together vinegar and salt for a good surface cleaner. OR

Dissolve 4 tablespoons of baking soda in 1/4 gallon of warm water. OR

Use baking soda on a damp sponge.

Disinfectant

Soap. Regular cleaning with plain soap and hot water will kill some bacteria.

Keep dry. Mould, mildew and bacteria cannot live without dampness.

Borax has long been recognised for its disinfectant and deodorising properties. It is a safer alternative to some disinfectants but it is toxic. Keep out of reach of children and animals, and use caution while applying it. Mix 1/2 cup of borax into 1 gallon of hot water and clean with this solution.

For glass:

Use vinegar and water (1 part vinegar to 4 parts water), let dry and polish with newspaper.

For furniture polish:

Mix 3 parts olive oil to 1 part vinegar. Apply and polish with clean soft rag.

OR

Mix 2 parts olive oil and 1 part lemon juice. Apply and polish with a soft cloth.

(You could try other vegetable or mineral oils instead of olive oil. Experiment on a small piece of wood first.)

CONTROLLING HOUSEHOLD PESTS

Fleas

Mix 1 teaspoon of vinegar to 1/4 gallon of water (per 40 lbs of animal weight) in an animal's drinking water. This helps to keep the animal free of fleas and ticks.

Roaches

Place bay leaves around cracks in the room. OR Set out a dish of equal parts baking soda and powdered sugar;

OR equal parts of oatmeal flour and plaster of paris;

OR chopped bay leaves and cucumber skins;

OR crushed tobacco and water. (This last one is poisonous to humans--use caution when handling.)

Ants

Pour a line of cream of tartar, red chili powder, paprika or dried peppermint leaves at point of entry.

CONTROLLING GARDEN PESTS

Natural pesticides are safer and usually cheaper than chemical pesticides, and they usually control the specific pest without harming other living things. Here are some to try:

1. Crush strong-smelling or strong-tasting substances, such as garlic, onion, hot peppers, herbs or spices, and soak in water. After the water has picked up the aroma or taste, spray it onto affected plants. Use a variety of substances in the solution to increase the chance of finding the right combination.
2. Treat insect-infested plants with a very mild soap and water spray (no bleach or detergent). Add strong-smelling or strong-tasting plant material to the soapy water to make it more effective. This treatment needs to be repeated after each rainfall.
3. Place small amounts of beer in shallow containers around the garden to attract snails or slugs.
4. Trap crawling insects in wood ash sprinkled on the ground around plants. The ash clogs their pores and they die.

Other methods of controlling garden pests include:

1. Encourage creatures such as insect-eating birds and toads into the garden to help keep insect populations down. Bring toads into the garden, and keep them there by providing them with a cool, shady place to live, such as a small box or a shelter made of twigs and plants. Toad homes should be in a quiet area of the garden.
2. Hand-pick pests. This is time-consuming but unbeatable. Use gloves and remove all visible offending pests.
3. Make a barrier of heavy paper, metal cans with both ends removed, or stones and sink 5 cm. (2 inches) into the earth around the base of a seedling. This prevents cutworms from getting to the stem. (Cutworms are grubs that live just under the soil surface and kill seedlings by cutting through their stems.)

ARTICLE

Mobilising Against Toxic Waste

SOURCE

The Tribune newsletter 49: Women, Environment and Development part II (February 1993). *The Tribune* is a Women and Development Quarterly newsletter published by the International Women's Tribune Centre, 777 United Nations Plaza, New York, NY 10017, USA. If reproduced, please credit the International Women's Tribune Centre and artists, Laurel E. Douglas and Anne S. Walker, and send copies of reproduced material to the IWTC.

SUGGESTIONS FOR USE

Community workers: In "how-to-do-it" meetings as encouragement for people planning a toxic waste campaign.
Radio broadcasters, journalists: In reports on how to activate people on local toxic waste issues.



IN FEBRUARY, 1989, TWO REPORTS APPEARED ALMOST simultaneously in the Bangladeshi press. One described a proposed manufacturing plant which would use imported industrial waste; the other revealed that a U.S. ship was attempting to dump 15,000 tons of toxic incinerator ash into the Bay of Bengal. Dumping toxic waste off the coast of Bangladesh would destroy the fishing industry in that area, as well as threaten the health of humans, plants and animals living on the coast.

Reaction was swift. Starting in March of 1989, Naripokkho, a women's activist group in Bangladesh, mobilised women's organisations, human rights and legal aid groups, scientists, students and researchers to take action. They formed the "Foreign Waste Resistance Committee" to focus public attention and pressure on the government to stop toxic waste threats.

Hundreds of women participated in activities. They conducted a nationwide signature campaign, demonstrated, wrote newspaper articles and held seminars and press conferences to educate the public about the effects of industrial waste on public health. These activities cost about 20,000 Bangladeshi taka and many hours of volunteer time.

As a result of the campaign, the two toxic waste issues were addressed by October 1989. The proposed industrial waste-based plant was cancelled. The Government of Bangladesh sent its Navy to protect its territorial waters. Joined by the Indian Navy, the fleets searched the sea, but they could not confirm if waste had been dumped.

The most important outcome of these actions, however, was the increase in public awareness of toxic waste threats. The group, renamed the "Environment Protection Committee", continues to operate with a wider mandate on environmental matters.

From: "Success Stories", *Global Assembly of Women and the Environment*, 1991



Oil Spill!

SOURCES

"Gulf oil spill leaves massive environmental toll" in *World Resources 1992-93: a Guide to the Global Environment*, A report by the World Resources Institute in collaboration with The United Nations Environment Programme and The United Nations Development Programme (1992, Oxford University Press, New York/Oxford)

"Persian Gulf Update: War on the Environment" by David J. Fishman, *ScienceWorld* April 5, 1991 Vol. 47, No.14 published by Scholastic Inc., USA)
The map is from *ScienceWorld* April 5, 1991. Reprinted by permission of the publisher, Scholastic Inc.

SUGGESTIONS FOR USE

Teachers: As source for class discussion on oil spills and methods of clean-up.

Radio broadcasters. Journalists, NGOs: As a starting point for programmes/articles/projects that consider (a) the precautions necessary to avoid local oil spills or (b) the merits of making contingency plans for oil spills.

Among the casualties of the Persian Gulf war was the earth itself. On 19 January, 1991, oil was deliberately released from Kuwait's Sea Island terminal by Iraqi soldiers. Estimates of how much oil oozed into the Persian Gulf, primarily from this site, varied widely. By mid-1991, the estimate was 950,000 cubic metres. That was nearly twice the previous record spill at Ixtoc, a drilling rig blowout in the Gulf of Mexico. In June 1991, Saudi officials reported that the terminal and sunken tankers were still releasing about 400 cubic metres each day, but by August, the leaks were estimated at 75 metric tons daily.

From Kuwait, the massive spill moved steadily southwards along the coast of Saudi Arabia. The water was so thick with oil that one observer said it "heaved like mud." The slick forced the Saudis to shut down several giant desalination plants because they feared the plants would be polluted by the oil. (The desalination plants - which turn salt water into fresh, drinkable water - provide more than 90 per cent of Saudi Arabia's drinking water.)

As the oil moved southwards, it threatened important nesting sites for more than 1,000 green sea turtles. It washed over thick seagrass beds, where most of the Gulf's 7,000 endangered dugongs feed during the winter. With their main source of food coated with toxic oil, many of these vegetarians would die. The population of seagrass shrimp was also destroyed, thereby collapsing the local shrimp industry.

The oil affected about 350 miles of Saudi coastline. It inundated mangrove swamps where billions of young fish live among the twisted roots of these ocean-growing trees. Oil

suffocates fish because their gills become clogged. Ninety per cent of Saudi Arabia's salt marshes were affected. These wetlands support millions of resident and migratory birds. Oil damages birds' feathers and seeps into birds' eggs, killing the embryos.

The Gulf's coral reefs, created by the secretions of tiny marine animals called polyps and providing food and shelter for a myriad of fish and other marine creatures, could also face death. Oil that sinks from the surface can kill the reef's thin layer of living polyps. It could take hundreds of years for the corals to grow back.

The clean-up efforts had few successes. Booms, nets and skimmers were used to protect the water-intake pipes of the Saudi desalination plants and refineries. Booms are floating barriers that keep the oil from spreading, and skimmers are machines that scoop up oil. It was claimed that 300,000 cubic metres of crude oil was scooped up. This would be the most oil recovered from a major spill.

But the bays or inlets were not protected. 20,000 to 30,000 birds were killed and the salt marshes were matted with oil. In addition, Kuwait's burning wells emitted large quantities of soot, some of which fell into gulf waters.

Assessing the long-term damage is difficult. And the value of clean-up techniques remains uncertain. Some scientists, for example, question whether spraying hot water at high pressure to remove oil (as was done in the clean-up of the 1989 *Exxon Valdez* tanker spill, Alaska, USA) may delay the recovery of an ecosystem.

One clean-up technique which was considered in the Gulf was the introduction of naturally-occurring oil-eating bacteria. These

AT RISK IN THE GULF: WILDLIFE AND DRINKING WATER

Adapted from *ScienceWorld* April 5, 1991 by permission of the publishers, Scholastic Inc., 730 Broadway, New York NY 10003, USA

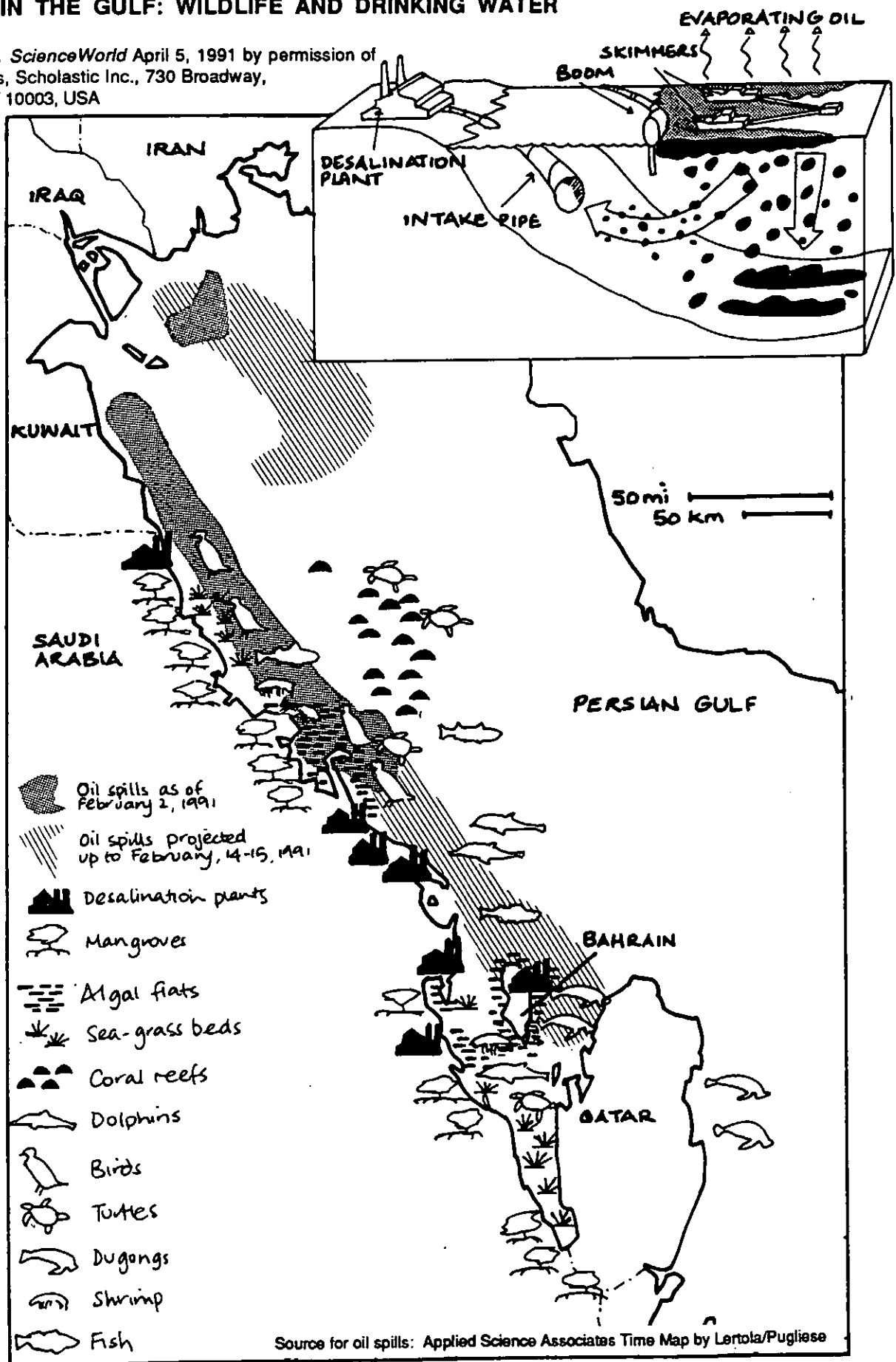

hungry microbes could feast on the oil compounds washed up on beaches, turning them into harmless by-products. This technique was used in the *Exxon Valdez* spill, but Saudi officials rejected its use because it is still a

relatively unproven technology. They also resisted sprinkling the shoreline with nitrogen-based fertilisers, which could help degrade the oil but which could also cause algal blooms in the Gulf.

CLASS/GROUP ACTIVITY

Cleaning Up Oil Spills

SOURCE

Adapted from "Oil Spill" in *Earthnotes for Educators Grades K-6*, (Fall, 1991) produced by the U.S. Environmental Protection Agency, 401 M Street, S.W. (A-107) Washington, D.C. 20460 USA. If reproduced, please credit original source.

SUGGESTIONS FOR USE

Teachers, Youth leaders: As a classroom/group activity for students to appreciate the difficulties of dealing with an oil spill.

In the Persian Gulf, containment and recovery were the two main methods used in the clean-up. Floating booms prevented the spilled oil from reaching desalination plants. Skimmers collected the spilled oil from the water's surface by suction and other means. Other oil spill clean-up methods include *bioremediation*, in which microbes help degrade the oil; *sorbents*, such as straw or vermiculite, which help absorb the oil; and chemical dispersants, which act like detergents, to break up the oil. A combination of methods are often used in clean-ups. Unfortunately, there is no method that can clean up a spill completely.

You can see for yourself which clean-up method works best. (This activity may be conducted by groups of students, or, to keep materials and equipment to a minimum, students can assist the class teacher or group leader.)

What you need:

- * corn or olive oil;
- * 6 bowls of water;
- * spoon;
- * twine;
- * an eyedropper;
- * handful of sand;
- * different types of papers (e.g. brown paper, newspaper)
- * liquid detergent.

What to do:

1. Drop a spoonful of oil onto the water in 6 bowls. Each bowl of water represents a "lake", and the oil represents an "oil spill".
2. In the first "lake", use a circle of twine to *contain* the oil.
3. In the second "lake", use the eye dropper to *recover* the oil.
4. In the third "lake", *remove the oil by sinking*, using the sand.
5. In the fourth "lake", see how effective the different papers are at *removal by adsorption*.
6. Use detergent in "lake" 5 to see how effective it is in *dispersing* the oil.
7. Once all the clean-up methods have been observed, discuss the advantages and disadvantages of each method.
8. Then, try cleaning up the oil spill in the sixth "lake" using a variety of the methods above, or by using other objects that you think might work (e.g. rubber bands, cotton, cloth, saw dust, pencil shavings). Do the methods eliminate the oil from the environment or do some only remove it from sight?

(Booms keep the oil in one place, but don't remove it from the water; skimmers scoop the oil, but it is difficult to recover all the oil; materials that sink oil, simply change its location in the water.)

ISSUE 95

Learning-By-Doing Leaflets on Waste and Recycling

CONTENTS

	Page(s)
OUTREACH Learning-By-Doing Leaflets	ii-iii
Learning-By-Leaflets in issue 95	iii
Leaflet no.	
81 What a waste!	1-2
82 Danger! Hazardous materials - spread the message not the waste	3-4
83 That's rot!	5-6
84 Sifting scrap	7-8
85 Making new things from old (1) A paper caper	9-10
86 Making new things from old (2) Yesterday's news, tomorrow's shoes!	11-12
87 Making new things from old (3) Turning grease and dirty ashes into clean soap	13-14
88 Making new things from old (4) Soap suds	15-16
89 Making new things from old (5) Making a living from paper bags	17-18
Teacher's notes on Waste and Recycling	19-40

ACKNOWLEDGEMENTS

These Learning-By-Doing Leaflets were written by Gillian Dorfman and edited by James Connor, M.S., Ed.D.

OUTREACH LEARNING-BY-DOING LEAFLETS

The OUTREACH Learning-By-Doing leaflets have been especially designed for middle and high school teachers in Low Income Countries. It has been recognised that good learning materials are scarce in many classrooms in the South. Textbooks are not always available. Those that are available are not always relevant to the most pressing problems in the Developing World, including health and environmental problems and sustainable development. The purpose of the Learning-By-Doing leaflets is to help fill the needs, at least in small part, of middle school and high school teachers in Low Income Countries by providing inexpensive, classroom-ready materials that will help to foster a scientific attitude in students. They are meant to supplement and enrich the science curriculum, not replace it, and they are meant to be used in any way that is most useful to the classroom teacher. In other words, they can be adapted, adopted or added to in order to meet local needs. They may be used, copyright-free, for any non-profit purpose in Low Income Countries. The Learning-By-Doing leaflets may be published in the North, with profits being used for the further development and publication of learning leaflets on other topics for use in the South.

Fostering a scientific attitude

The philosophy behind the science leaflets is that science teaching should not be telling students what to think and believe. Rather, science teaching should foster a scientific attitude - the attitude which appreciates the value of forming ideas based upon observations and reliably testing information, and being content to say, "I don't know" until the evidence is sufficient to answer the question. Science teaching should allow students to find out things for themselves through scientific inquiry. The Learning-By-Doing leaflets, as the name implies, include a variety of hands-on activities designed to foster a scientific attitude towards solving the most pressing health and environmental problems facing people all over the world. This scientific attitude can be useful in all areas and levels of inquiry in the classroom and for problem-solving in every day life as well.

Adaptable

Each leaflet is self-contained. Teachers can pick and choose the topics that they would like to cover to supplement their science programme and to help meet the curricular specifications of their local education ministries. In addition, each of the leaflets and accompanying teacher materials provide a number of suggestions for additional, more in-depth activities, so that the leaflets are adaptable to a wide range of classroom levels, from primary to high school.

The leaflets are adaptable in many different climatic and cultural situations, since their focus is on basic scientific principles and scientific inquiry. A particular technology may be appropriate in one area, but not in another. Therefore, the focus of the leaflets is not on providing information about specific technologies, such as how best to plant a specific crop. Rather, the leaflets provide some basic scientific information and tools of scientific inquiry which students can use to closely examine technologies being used in their own areas and to test and perhaps improve upon these technologies.

Inexpensive

The contents of each Learning-By-Doing leaflet cover two sides of a sheet of paper. When folded down the middle, it becomes a four-page leaflet. The materials required in the activities are readily available, even in the most rural areas, and are not costly.

Relevant

When engaged in the tasks outlined in the leaflets, the students are in contact with their surroundings directly, through the senses, because they deal with concrete things in the world around them. Moreover, the leaflets cover very practical problems in the students' own lives, especially those related to health, the environment and sustainable development. The students learn through their own investigations of real problems, which is as sound a basis for education as one could desire.

Motivational

Children demonstrate a natural curiosity about the natural world around them. In their every day lives, children like to watch things grow and develop. They like to manipulate things and observe what happens. The Learning-By-Doing leaflets take advantage of the natural curiosity of children by focusing it towards learning how to solve practical environmental and health problems. Students are allowed to take an active learning role by actively constructing their own meanings in the classroom. When allowed to make discoveries on their own, students become excited about the learning process and are self-motivated to learn more on their own.

Inter-curricular

Teachers the world over complain that there is no time to teach science, since basic literacy is their main concern. The health and environmental problems that are the focus of the leaflets can be a suitable "unifying" subject in the classroom, as it has many links with other subjects. In the course of their investigations, students have many chances to practise their reading, writing and speaking skills. They are also encouraged to tap into and build upon the knowledge of their elders, and to bring home and make practical use of what they have learned in the classroom.

LEARNING-BY-DOING LEAFLETS IN ISSUE 95

In this set of Learning-By-Doing Leaflets, students learn about waste in their community, particularly municipal solid and hazardous waste. The emphasis in the leaflets is finding solutions to the waste crisis: students are encouraged to consider ways to reduce waste; they discover safer alternatives to hazardous materials, thereby reducing hazardous wastes; they investigate decomposition of waste and how this process can be speeded up; and they make useful products from waste materials. Issues relating to the establishment of recycling businesses are explored, too.

PLEASE NOTE: The Learning-By-Doing leaflets in this pack are intended for secondary school students under the direct supervision of adults. OUTREACH cannot be held responsible for any injuries or accidents that may result from conducting the activities without proper supervision, from not specifically following directions or from ignoring cautions included in the text. Teachers and other adult supervisors should read instructions carefully before commencing activities.



LEARNING-BY-DOING HEALTH & ENVIRONMENTAL ACTIVITIES FOR YOUNG SCIENTISTS LEAFLET NO. 81

- If you can identify who the 'dumpers' are, you can run a campaign that is directed at these people to inform them of the hazards of dumping or to suggest more appropriate ways to get rid of rubbish. Your message to the dumpers may be presented in posters, leaflets, plays or through letter-writing campaigns.
- Organise your friends to clean up a waste site. You may need to recruit some grown-ups to help you. Perhaps, you can 'adopt' your survey area, and take responsibility for always keeping the area litter-free.

Activity 4: Are you a litter-bug?

How aware are you of the cleanliness and appearance of your environment? Test yourself, your family and friends. Answer the questions truthfully. Circle the relevant numbers:

	Never	Rarely	Don't know	Sometimes	Always
Do you drop wrappers in the street?	5	4	3	2	1
Do you leave litter around because you think it is not easy to find a receptacle to put it in?	5	4	3	2	1
If you see discarded litter, do you pick it up?	1	2	3	4	5
Does the sight of litter offend you?	1	2	3	4	5
Are you prepared to take part in a litter-clearing campaign?	1	2	3	4	5
Do you live by the principle: Leave a place cleaner than you found it?	1	2	3	4	5

Add up the points you have scored for each question:

- 30 - 28: You are highly litter-minded
 - 27 - 24: You are concerned about the cleanliness and appearance of the environment
 - 23 - 21: You could improve
 - 20 and below: You must do something to improve your litter mind!
- (Adapted from an idea of Community Service Volunteers, UK)

OUTREACH pack 95 pp 1-2. Other Learning-By-Doing Leaflets and Information packs are available from Dr. James Connor, OUTREACH Director, Environmental Education Center, 200 East Building, New York University, New York NY 10003, U.S.A. or Richard Lumbe, OUTREACH Coordinator, Information & Public Affairs, UNEP, P.O. Box 30552, Nairobi, KENYA

What a Waste!

When you eat a fruit, do you eat every part of it? Do you eat the skin of a banana or the pit of an orange? You probably throw these away. Can you think of other things that you discard?

When something is used up or no longer serves a purpose, it is generally thought of as *waste* and is thrown away. Throwing away rubbish - from homes, from mines and factories, from shops, hospitals and farms - can create eyesores and health hazards, and can waste valuable natural resources.

In this leaflet, you will identify the types of waste you and other people in your neighbourhood throw away, and the problems that this waste creates. Armed with this information, you may consider ways to reduce the amount of waste produced by your community, and think of ways to make use of local waste materials. You may also decide to help organise local clean-up projects.

Activity 1: A Survey of Household Waste

In this activity you are going to find out what type of waste you and your family throw out. Before you begin to collect and sort the household trash, make a guess as to which items you think your family throws out most. (Make your selection from the following items: food; paper; glass; wood; plastic; metal; cloth; other.) Record your guesses here:

The biggest pile of rubbish would be _____
 The second biggest pile of rubbish would be _____
 The third biggest pile of rubbish would be _____

To carry out this activity you will need:

- * some newspaper,
- * gloves (or plastic bags to put over your hands and elastic bands fixed at your wrists to hold the bags in place);
- * a plastic bag;
- * a large bag or cardboard box;
- * paper and pencil to record results.

(Warning: Do not touch any materials or containers such as corroded

batteries or pesticide containers, that you think are harmful to your health. If hazardous materials are seen, tell an adult who can arrange for its safe disposal.)

1. Have everyone in your household keep all items that would normally be thrown away. Place all food scraps in the plastic bag. (Keep the bag away from animals and young children.) Place all other rubbish in the large bag or cardboard box.
2. At the end of the week (or before if the food scraps are beginning to smell too much!), empty the contents of the rubbish container (not the food scraps) onto sheets of newspaper. (Remember to wear gloves.)
3. Sort the rubbish into piles of different types. For example, cardboard boxes would be paper products, tin cans would be metal, and so on. The categories you chose may be similar to the ones in the following chart.
4. Rank the piles of waste material (including the food scraps) from the biggest to the smallest in size. Record your results on a chart similar to the one below:

Waste piles ranked in order of size (by volume)

	A week's trash
food waste	
paper	
metal	
plastic	
glass	
wood	
rubber	
cloth	
other (e.g. things made of a combination of the above)	

Were your guesses accurate? Can you think of a way to work out the volume of each pile of waste. (Hint: You could use a cardboard box.)

Once you have completed your investigation of household waste, put the rubbish where your family normally disposes of it. Then, clean your hands with soap and water. (Why is this so important?)

Compare your results with those of your classmates. Discuss ways you and your classmates might reduce the amount of waste your households produce.

Activity 2: Studying waste in your neighbourhood

You can investigate the waste that is dumped in your community.

Draw a map to define the area where you live. Mark the following features on the map:

houses, shops, factories, farms, roads, railways, watercourses (canals, streams, rivers, drainage ditches etc.) and open spaces.

You may select all or part of the area to survey. Carry out the

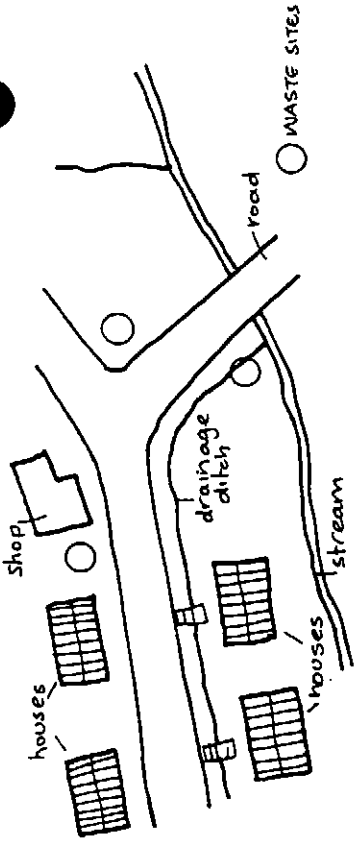

following tasks in your survey site. You will need paper and a pencil.

(a) Where waste occurs

Walk around the district, and note on your map where waste has been thrown away. Look on the streets, at the back of shops, in factory yards (a glance through the fence should tell enough), in drainage ditches and so on. Visit the official community dump.

(b) Types of waste

List the waste items that occur at the various places where waste is found. You can probably find out more information by talking to people at the sites such as factory workers and dumpsite collectors.

Are there any unusual items found amongst the rubbish? Can you think of new uses for some of the items you discover?

(c) Be a dump detective

At the dumps or in the streets, can you find information that tells you where a particular type of waste has come from? Labels on cans or drums, letters or boxes with a trade name printed on them are some clues you may discover. Perhaps, you can identify local businesses as the culprits of waste dumping. Find clues about the people who have dumped the trash. (For example, do they read? Are they heavy smokers?) Write stories about the people who have dumped rubbish at a particular location.

(d) Waste Hazards

Can you spot any waste problems? For example, is waste clogging up drainage channels and forming pools of still water that serve as breeding grounds for mosquitoes? Is there rotting food that is attracting flies? Mosquitoes and flies transmit a variety of diseases. Are children playing near the rubbish piles? Is there waste that is harmful to people and animals? Think about what can be done to reduce these hazards.

(e) Waste over time

Study the area over time to see if the waste is collected or if more waste is added.

After these surveys have been completed, groups should gather together all their findings about neighbourhood waste and present them to community leaders.

Activity 3: Tackling waste

1. If you have identified waste materials that could be recycled, collect these items and pass them along to people who could make use of them.

Activity 5: Testing safer household cleansers

You will need:

- * a large surface area, such as
 - * baking soda and water.
 - * some cleaning solution using the recipe shown in Activity 4;
 - * various containers;
 - * cloths for applying cleansers;
 - * tape;
 - * paper and pencil.

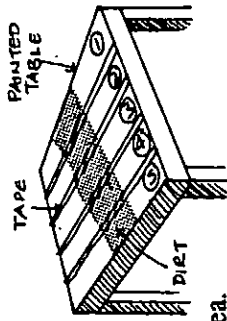

1. Prepare the surface by dividing it into five areas. Use the tape to label each area (1) water only; (2) soap and water; (3) vinegar and salt; (4) baking soda and water (5) cleaning solution.
2. Rub equal amounts of dirt into each area.
3. Guess which cleanser you think would work best. Record your guess here: _____
4. Use the appropriate cleanser on each area of the surface.
5. On a chart similar to the one shown below rank the cleansers according to which works best (1 = best cleanser; 5 = worst cleanser)
6. Repeat steps 2 to 5 but apply grease to the surface, not dirt.
7. Repeat steps 2 to 5 but apply a combination of dirt and grease.

Now answer the following questions:

1. Which is the best cleaner for removing dirt? For removing grease? For removing grease and dirt?
2. What substance (dirt, grease or dirt/grease combined) does soap and water clean best? What does vinegar and salt clean best? What does the cleaning solution clean best? Were your guesses (step 3) accurate?

The cleanser that removes:	dirt best	grease best	grease/dirt best
water only			
soap and water			
vinegar and salt			
baking soda and water			
cleaning solution			

Extension Activity: Try this experiment using other cleaning surfaces.

Activity 6: Spreading the message, not the waste

You can encourage others who are using hazardous commercial products to switch to the natural methods and materials that are safer for health and the environment. For example, you can design a poster that advertises the cleansers described above.

Source of reference: *Stepping lightly on the Earth*, a leaflet produced by Greenpeace, 1436 U Street, NW Washington, D.C. 20009, USA
 OUTREACH pack 95 pp 3-4. Other Learning-By-Doing Leaflets and Information packs are available from Dr. James Connor, OUTREACH Director, Environmental Education Center, 200 East Building, New York University, New York NY 10003, U.S.A. or Richard Lumbe, OUTREACH Coordinator, Information & Public Affairs, UNEP, P.O. Box 30552, Nairobi, KENYA



LEARNING-BY-DOING HEALTH & ENVIRONMENTAL ACTIVITIES FOR YOUNG SCIENTISTS LEAFLET NO. 82

Danger! Hazardous Materials - Spread the message not the waste

There may be dangers lurking in the home, in the garden and on the farm and you may not even be aware of them! The dangers are household and garden chemical products that can make you sick if you eat or drink them. And some can harm you if you breathe in their fumes or touch them. The aim of this learning leaflet is to make you and others aware of the hazards of using and throwing away these toxics, and to introduce alternatives that are safer for people and the environment.

Activity 1: What are hazardous materials?

(a) Here are some pictures of household products. Could any of these harm you if you ate or drank them, breathed in their fumes or touched them? (*Do not experiment with these products if they are in your home.*)

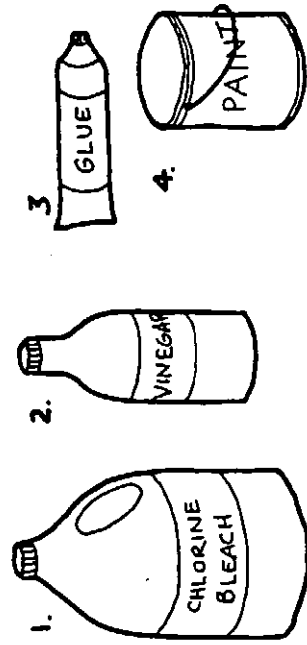

Items that produce harmful effects in people and other living things are called hazardous materials.

How can you discover which products are dangerous without harming yourself? The easiest clue is the warning labels that should be printed on the product. What words or pictures on product labels indicate to you that the contents are poisonous or may cause injury?

Activity 2: Warning labels

(a) Words such as DANGER, CAUTION or WARNING, and pictures such as a skull and crossbones may be on labels. There may be other warning labels, too. See which household products have the following words on their containers: TOXIC or POISONOUS, CORROSIVE, INFLAMMABLE, and REACTIVE. These words help describe the type of hazardous material in the container. To find out the meanings of these words, follow the lines below that link the words to their meanings:

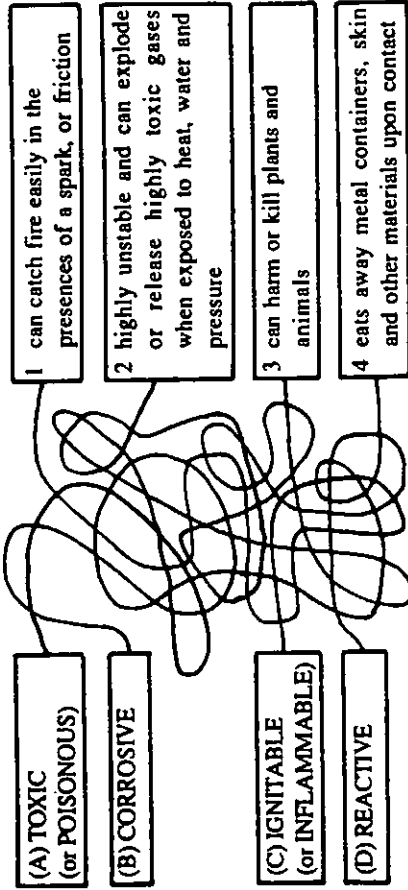

- (b) Make a list of products in your house that show any of the above warnings. Draw pictures of the containers, and include in your drawings any symbols you find that might also indicate a hazardous material. Do you think the instructions and warnings on the labels can be improved? Are the hazardous products kept out of reach of young children? Why is this important? What are these hazardous substances used for? Repeat this exercise in a neighbourhood shop for food, garden/farm supplies, drugs, paint etc.
- (c) Design a container label for a hazardous product found in your home. The label can include the product name, purpose of the product, application instructions and safety and disposal information. How will your label warn someone who cannot read? Can you think of a symbol that will warn young children to stay away from the product? What colour is your label? Put your label on the hazardous product that is kept in your house. (*Make sure your label does not hide any safety or other instructions on the containers.*)

Activity 3: When do hazardous materials become hazardous waste?

Hazardous materials become hazardous waste when they are no longer wanted and are thrown away or when materials are spilled or released into the environment. For example, a partially-used can of paint is a hazardous material when it is stored on a shelf, but it becomes a hazardous waste

when it is discarded. A leak from an oil storage tank contaminates the ground with hazardous waste, even though the oil is a usable product.

Ask your parents how they get rid of (a) pesticides (b) used batteries (c) old paint. Can these disposal methods cause problems? Find out from your local authorities how hazardous materials are - or should be - disposed of in your locality. Think of ways to publicise these methods.

Using safer alternatives

Many of us like to think that widespread pollution of groundwater, soil and air is entirely due to the irresponsibility of large industry. But we may also be contributing to the poisoning of the planet. Substances used in homes, at school and on the land, such as paint thinners, batteries, pesticides, cleaners and solvents can become hazardous waste.

There is no completely safe way to dispose of toxic waste. What we can do is to reduce our usage of hazardous materials by using safer alternatives instead. Alternatives to "household toxics" are usually more time-consuming to prepare, but they are cheaper than commercial products, and they are better for our health and for the environment.

Activity 4: Making a household cleanser

Most household cleaning needs can be met with six simple ingredients:

Vinegar
Soap

Cuts grease.
Biodegrades safely without polluting water. Sold as liquid, flakes, powder or in bars. (Check ingredients on label to avoid synthetic scents and other additives.)

Baking soda

Cleans and deodorises. Good scouring powder. Softens water, increasing the cleaning power of soap.

Washing soda

Disinfects. Cuts grease and removes stains.

Borax

Cleans, deodorises and disinfects. Softens water.

Ammonia

Cuts heavy grease and grime, but it can be hazardous. Use only as a last resort, when other cleaners are not strong enough to remove dirt. Fumes irritate eyes and lungs. *Never mix ammonia with chlorine bleach or commercial cleansers -- deadly fumes may form.*

Various combinations of these simple substances can do most household cleaning jobs. *Use caution with all cleansers. Even some non-toxic cleansers are unsafe to swallow.*

To make an all-purpose cleanser, you will need:

- * 1 litre (approximately 1 quart) water;
- * 5 ml (1 teaspoon) soap;
- * 10 ml. (2 teaspoons) borax;
- * washing soda or vinegar;
- * spray bottle.

Mix borax and soap with water, and store in a spray bottle. Add vinegar or washing soda to cut grease. This solution is effective for many cleaning jobs.



LEARNING-BY-DOING HEALTH & ENVIRONMENTAL ACTIVITIES FOR YOUNG SCIENTISTS

LEAFLET NO. 83

7. Was the hole lined before dumping began? (If so, what material was used as a lining?)
8. How much rubbish is being dumped every day? Every week?
9. How much rubbish can the dump hold, and when is it likely to be full?
10. What types of materials are dumped on the site?
11. Is any hazardous material dumped on the site?
12. Has material that can be re-used, recycled or composted been removed before rubbish is dumped on the site, or do people sort out the rubbish after it has been dumped?
13. How long is the rubbish on the dump left exposed to air before any material is placed on top of it?
14. Is the dumped material compacted (squashed down), and what effect does this have?
15. Are layers of dirt put in between layers of rubbish?
16. Is the rubbish dump covered each night with covering material such as soil?
17. Is leachate collected? (Leachate is liquid that has soaked through solid waste and/or been created by rotting garbage, and has dissolved or suspended materials such as bacteria and toxic substances in it.)
18. Is groundwater tested for leachate pollution?
19. Is methane gas (given off by rotting garbage) recovered? If so, what is the gas used for? To heat homes, to cook food?
20. Have measures been taken to avoid fires from breaking out?
21. Are rats and other disease-carrying animals present?
22. Is the dump closed at night?
23. Are there are washing facilities available for people working on the dump?
24. Have plans of the site been drawn up to show what will happen to the dump when it is full?
What do you think about the dump? Will the rubbish be able to break down easily? Is as much waste as possible re-used, recycled and composted before it ends up in the dump? Do you think the dump is a safe place to live near and work at? What improvements would you make to the dump?

Prepare a report on your survey findings. Use drawings and charts to illustrate the text. Present your findings to the owners of the dump, to the local authorities and to the local community so that these groups can determine if improvements ought to be made.

Sources of reference: Jean F.Bonhotal & Marianne E.Knasy, *Composting: Waste to Resources*, A Cornell Cooperative Extension Publication, Cornell University, New York USA (1990); *SuperScience Blue Edition* Vol.2, No.1 September, 1990: "Rot That!" published by Scholastic Inc. 730 Broadway, New York, NY 10003 USA.

OUTREACH pack 95 pp 5-6. Other Learning-By-Doing Leaflets and Information packs are available from Dr. James Connor, OUTREACH Director, Environmental Education Center, 200 East Building, New York University, New York NY 10003, U.S.A. or Richard Lumbe, OUTREACH Coordinator, Information & Public Affairs, UNEP, P.O. Box 30552, Nairobi, KENYA

That's Rot!

Rubbish may be left in the street or taken to dumps to rot. Rotting rubbish piles become smelly, and unpleasant to look at. Worse still, they attract flies and other germ carriers. So the faster the material rots, the better. This leaflet explores ways that the decaying process can be speeded up. Use what you learn to make a critical assessment of your local dump, and come up with ideas for improving it.

Activity 1: What rots?

You will need:

- * one piece of trash from the following categories:
 - food waste (such as an orange rind, apple core)
 - farm waste (weeds, leaves)
 - paper (e.g. newspaper, a piece of cardboard)
 - metal (e.g. a key, a piece of wire, a soda can tab, paper clip)
 - glass (e.g. a small glass bottle);
 - cloth (e.g. an old sock, a scrap from a torn shirt)
 - wood (e.g. some pencil shavings, sticks)
 - plastic (e.g. a small plastic bag)
 - 8 transparent plastic bags
 - * pencil and paper for recording results
 - 1. Examine each of the eight items. Use your sight, smell and touch to describe the colour, texture, shape and feel of each one. Write down which items you predict will change in (a) a week (b) two weeks and (c) a month.
 - 2. Put each item in its own plastic bag, and tie the bag so the item is sealed in. Set them aside for a week.
 - 3. After one week, find out which items have changed, and which have not changed. Record your observations.
 - 4. After two weeks, record new changes.
 - 5. After a month, record new changes. Which items have changed? Were your predictions correct? Which items have not changed? Do you think these items will change after a year, after several years?
- IMPORTANT:** After completing this experiment, carefully bury the 'change' bags without opening them. Some moulds that feed on organic material and help it rot can make you sick.

Activity 2: Aids to decay

What helps stuff rot or breakdown? Here is an experiment to test variables, such as water, soil, air and light, that may or may not help make stuff rot:

- * You will need:
- * 5 pieces of banana peel, all the same size;
- * 5 transparent plastic bags;
- * water;
- * soil taken from a place likely to contain microorganisms, such as under a tree or a bush;
- * pencil and paper for recording results.

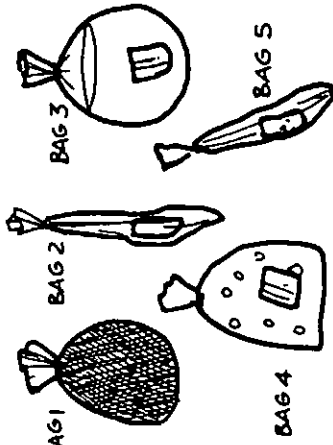

1. Put a piece of banana peel in each of the plastic bags.
2. In bag 1, cover the peel with soil. Squeeze out most of the air, and tie the plastic bag to seal it.
3. In bag 2, squeeze out the air, seal the bag, and leave it in a sunny place.
4. In bag 3, cover the peel with water. Squeeze out as much air as possible and tie the bag to seal it.
5. In bag 4, poke holes in the bag, and leave it open so the peel is exposed to air.
6. The peel in bag 5 is to serve as your control. It will not be exposed to air, soil, water or sunlight. Squeeze out the air and seal the bag.
7. Place all the bags, except for bag 2, in a dark place, and leave for a week.
8. After one week, look at the bags, but do not open them. Do you notice any changes in the banana peels? Consider colour and texture. Record the changes in a chart similar to the one below:

Observations	1 Soil	2 Light	3 Water	4 Air	5 Control
Changes in peel after 1 week					
2 weeks					

9. After two weeks, repeat step 8. Did all the peels change? Did the peels change in the same way? Which changed the most, the least?
 10. Bury the unopened bags once you have completed this experiment.
- Extension Activity:** Test other variables on the banana peel. Also try this experiment but instead of pieces of banana peel use pieces of newspaper or other waste items.

Activity 3: Make a 'rotting pot'

From the previous experiment, you should know which variables help make stuff rot. Now try making a 'rotting pot' -- a container in which stuff can decay fast. You will need:

- * a large transparent container (Probably, the best type is a 2-litre plastic soda bottle which has had the top cut off. Keep the cut-off top.);
- * samples of rubbish (items described in Activity 1);
- * soil with microorganisms;
- * water;
- * tape.

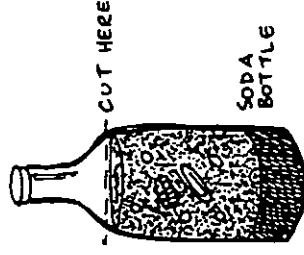

1. Place trash in the container, and use what you have learned in Activity 2 to add the things you think will help the trash rot quickly. Think about how these things should be added. For example, if you think air is a requirement for speedy rotting, you may simply puncture the container, or you may try to work out a more elaborate ventilation system. You may decide to add the container top to the pot and seal it with tape, or you may leave the top off the pot for all or part of the time.
2. Once the pot has been prepared, it should be left undisturbed for a few months. Decide whether the pot should be left in the dark or light, in a place that is dry or humid, warm or cool, windy or sheltered.
3. Check on the 'rotting pot' on the same day each week, and observe and record any changes you notice.
4. Can you think how you might be able to improve your 'rotting pot'? One suggestion: have your friends carry out this experiment at the same time. They can prepare their pots in different ways, and you can all compare results to find out which 'rotting pot' works best.

Activity 4: Investigate your local rubbish dump

Use what you have learned in the above experiments to find out how well rubbish rots at your local dump. You can also look at how safe the dump is.

- (a) Draw a plan of the dump which shows the size of the landfill, and its situation in relationship to nearby houses and other buildings, roads, rivers, streams and other drainage channels, etc.
 - (b) Below is a list of things to look out for, and questions to ask the people at the dump. (You may need permission to visit the dump.)
1. How big an area is the dump site, and is it surrounded by a fence?
 2. How far away from the dump are (b) houses (b) sources of drinking water - streams, springs etc.?
 3. When rain falls on the site, where does it drain?
 4. Does the wind generally blow from the dump towards where people live or away from where people live?
 5. Who owns and operates the dump site?
 6. Is rubbish dumped in a depression, and how deep is the hole?



LEARNING-BY-DOING HEALTH & ENVIRONMENTAL ACTIVITIES FOR YOUNG SCIENTISTS

LEAFLET NO. 84

Then, take your new, reduced pile and think about the next step in separating the material. (If you have two piles, you will need to think of a separating method for both piles.) Record your result.

Keep trying steps to separate scrap until each of the materials is sorted into its own pile.

Activity 3: More challenges

You can try to separate some other recyclable materials along with the ones mentioned above. Here are some to try:

- * *glass* - e.g. glass marbles
- * *rubber* - e.g. rubber bands
- * *wood* - e.g. pencil shavings, small sticks

Activity 4: Design a recycling centre

Your ideas for sorting recycling goods may be the start of a brand new invention -- one that can form the basis of a recycling business.

You have worked out methods of separating your sample scrap materials. Now imagine how your methods can be used to separate trash for recycling at a large recycling plant. For example, do you think a magnet would work at a big recycling plant? How strong do you think the magnet would have to be? If materials are separated according to whether they float or sink, does this create problems when it is done on a large scale? For example, do the wet materials have to be dried afterwards? How can static electricity be used to pick up items in a recycling plant?

Design a machine that can separate all or some of the recyclable materials. Draw a diagram of your invention, and make notes to explain each step. Try making a model, and test it out to find out if it works. Keep a record of all you do and the results. Get witnesses -- family members and friends -- to sign dated entries of progress reports so that you have proof that the invention is your idea.

If the invention works, use it to start a recycling business, or approach local entrepreneurs, local community leaders or people already working in the recycling business to see if they want to be involved in your project. Before you take any of these steps, make sure you get sound business advice from an independent counsellor.

Adapted with permission from *WonderScience* magazine Vol. 4, No. 7 November 1990 on "Recycling".
Copyright 1990, American Chemical Society.
Other sources of reference: *SuperScience Blue* Edition Vol. 4 No. 7 April 1993; Endangered Species published by Scholastic Inc. 730 Broadway, New York, NY 10003, USA; *Super Saver Investigators*, an activity guidebook about solid waste and natural resources produced by Ohio Dept. of Natural Resources, USA (1990)

OUTREACH pack 95 pp 7-8. Other Learning-By-Doing Leaflets and Information packs are available from Dr. James Connor, OUTREACH Director, Environmental Education Center, 200 East Building, New York University, New York NY 10003, U.S.A. or Richard Lumbe, OUTREACH Coordinator, Information & Public Affairs, UNEP, P.O. Box 30552, Nairobi, KENYA

Sifting Scrap

Many people in Third World cities earn a living by sorting through rubbish to separate out what can be reused. Paper, plastic, scrap metal, textiles, glass even food scraps can all be sold for recycling.

Sorting through the rubbish takes time. If it was your job to separate the trash for recycling, could you think of a fast and easy way to do it? In this leaflet, you will explore ways to separate trash - fast.

Activity 1: Scrap properties

You will need:

A selection of scrap materials:

- * *plastic* - e.g. a straw cut into small pieces, or plastic bottle tops
- * *aluminium* - e.g. foil cut into pieces 5 cm x 5 cm (2 in x 2 in)
- * *other metals* - e.g. some paper clips or metal bottle caps
- * *paper* - e.g. exercise book paper cut into pieces 5 cm x 5 cm (2 in x 2 in)

A selection of testing equipment, including:

- * a magnet;
- * water and bowl;
- * a balloon;
- * card folded to make a fan;
- * sticky tape;
- * glue;
- * a sheet of wire or plastic mesh (like a window screen);
- * velcro;
- * a hammer (or heavy weight).

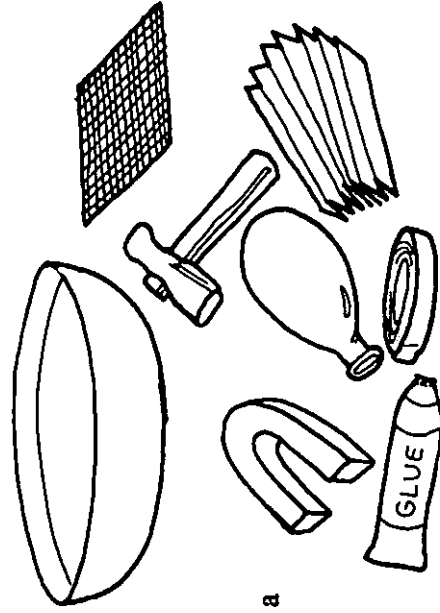

Take each of the scrap materials listed on the previous page, and use the equipment to perform some tests in order to compare the properties of the various materials. You can try the tests shown in the pictures below, but also think of other experiments to try, too. Before carrying out any tests, guess how the scrap materials will behave. Record your predictions on a chart similar to the one shown on the opposite page. Once you have recorded your guesses, carry out the experiments and record the actual results. Were your predictions accurate?

(a) Take a magnet and run it through the sample material to see if it attracts the scrap.

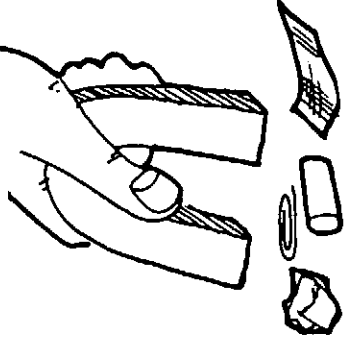

Is the material attracted or not attracted to the magnet?

(b) Place the material on a table, and use a paper/card fan to create short, gentle bursts of air near to the scrap.

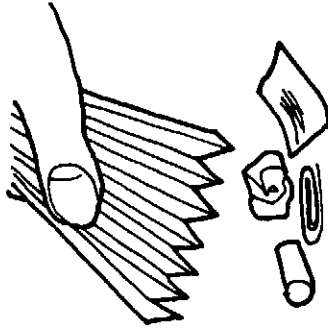

Is the material blown away by the fan?

(c) Take a balloon and rub it on your hair to create static electricity. Bring the balloon close to the material, and see what happens to the scrap.



Does the material jump to the balloon?

(d) Fill a bowl with water. Place the material on the wire mesh sheet and dip the sheet into the water so that it touches the bottom of the bowl.

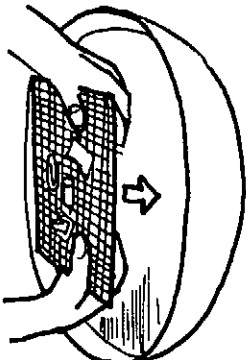

Does the material on the sheet float or sink?

Scrap materials	Tests			
	Attracted to magnet	Blown by fan	Floats	Jumps to balloon
Plastic prediction actual				
Aluminium prediction actual				
Other metals prediction actual				
Paper prediction actual				

Activity 2: Sorting the scrap

Now place all the scrap materials from Activity 1 in a pile. Study the chart above and think about the first step you could take to separate the scrap materials. You could separate out just one scrap material. Or you could use a sorting method that splits the pile into two piles, each of which would require further sorting.

Try your first step. Does it work? If not, try a new first step. If the first step does work, record what you have done. Your record may look like this:

	material separated			
	plastic	aluminium	other metal	paper
Step 1: use a magnet to attract scrap				
Step 2:				



LEARNING-BY-DOING HEALTH & ENVIRONMENTAL ACTIVITIES FOR YOUNG SCIENTISTS LEAFLET NO. 85

8. If you have an old-fashioned clothes mangle (wringer), you can put each 'sandwich' of felt, pulp and felt on a piece of hardboard, and squeeze it through the mangle. If you have no mangle, take each 'sandwich' of felt/pulp/felt and hang up to dry. The felt will drip a lot.

9. Peel the sheets of papers from the felts and leave to dry.
Note: The leftover pulp can be strained and composted.

Remember to record everything you do: the type and quantity of materials you use, and the steps you take. Note down the results. Also record any problems you have when making the paper.

What does your paper look like? Is it white, grey or another colour altogether? What makes your paper the colour it is? Is the paper crinkly or flat? What does the paper surface feel like -- rough or smooth? How can you make the paper more smooth?

You may have to try several times before you get a paper that you are satisfied with. For example, sometimes it helps to boil the slurry for longer or to add more water to make the pulp fairly thin. The finer the pulp particles, and the thinner the layer, the better quality of paper.

Use the paper for painting or drawing with charcoal, pencil or ink. How is this paper different from other writing or drawing paper?

How are energy and natural resources conserved by making and using recycled paper instead of making and using new paper?

Sources of reference: Jon Vogler, *Wort from Waste: recycling wastes to create employment* published by Intermediate Technology Publications Ltd. and Oxfam, 1981 (reprinted 1983), London; *Let's Reduce and Recycle: Curriculum for Solid Waste Awareness: Lesson Plans for Grades K-6 and 7-12* published by U.S. Environmental Protection Agency, 1980 (revised 1990), Washington, D.C. USA; *Waste Away: Information and Activities for Investigating Trash Problems and Solutions for Upper Elementary and Junior High Students* produced and published in 1989 by Vermont Institute of Natural Science, U.S.A.; *Junior Projects No. 42 "Paper"*, published by Scholastic Publications Ltd. UK (1989).

OUTREACH pack 95 pp 9-10. Other Learning-By-Doing Leaflets and Information packs are available from Dr. James Connor, OUTREACH Director, Environmental Education Center, 200 East Building, New York University, New York NY 10003, U.S.A. or Richard Lumbe, OUTREACH Coordinator, Information & Public Affairs, UNEP, P.O. Box 30552, Nairobi, KENYA

Making New Things From Old (1) A Paper Caper

Suppose there was not enough paper for everyone in your school to write on. What could be done? Well, the obvious answer is: hand out slates (blackboards) and chalk! But suppose you still had to solve the problem of insufficient school paper supplies. One solution might be to turn used paper back into new paper again -- to recycle! Making paper from waste is what this leaflet is all about.

Activity 1: Looking closer at paper

Tear a piece of paper, and look at a torn edge. What do you see? (Use a hand magnifying glass to see more clearly.) At the torn edge are fine, thread-like wisps. These are fibres. Paper consists of *cellulose*, the material found in many plants, such as trees and wheat, rice and sugar cane. Paper fibres can be recycled to make new paper.

Activity 2: Making pulp

For the first step in recycling paper you will need:

- * old paper, such as newspaper or old exercise book paper;
 - * a stirring spoon;
 - * a container;
 - * water;
 - * (optional) a hand magnifying lens: if this is not available, make one by filling a small round bottle with water and holding this over the object being viewed;
 - * (optional) cornstarch.
1. Remove any staples in the paper, and then tear the paper into small pieces about 2 cm x 2 cm (1 in x 1 in) in size. Look at the pieces of paper through a hand lens to see the

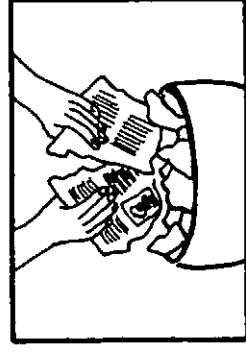

fibres close up. Place the scrap paper into a container. Cover with water (hot water if possible), and leave to soak for three or four days. Stir the mixture every day.

What does the mixture look like? What has happened to the paper fibres? Use a hand lens to find out.

The small shreds of paper suspended in the water as a slurry look like thick soup or oatmeal. You will see that the fibres are loose and free of the substances that binded them. This process of releasing the fibres is called 'pulping', and the mass of fibres, no longer held together but now suspended in water, is known as 'pulp'. The pulp is ready to use to make paper.

3. (optional) Add some corn starch into the mixture.

Activity 3: More pulp-making experiments

Alter the basic steps in Activity 2 in each of the following ways. Record what you do and the results you obtain.

(a) Make pulp from old newspapers and then from old exercise books. Would you have to alter the pulp-making process to prepare the latter? What colour is the pulp made from newspaper? From exercise book paper?

(b) Make the pulp from large pieces of paper and then from tiny pieces.

(c) Soak the paper for shorter and for longer periods.

(d) Add small amounts of shredded vegetable waste (e.g. orange peels, carrot tops) to the scrap paper in step 1 of Activity 2.

(e) Add different dyes to the pulp if you want coloured paper.

Activity 4: Making pulp from other waste

Because paper fibres consist of cellulose, you can make pulp from other wastes that are made from plant materials.

You will need:

- * a source of cellulose - for example, fine cotton rags, old paper, scrap wood, leftover crops, waste hemp;
- * meat mincer or a smooth stone and large rock;
- * water;
- * diluted caustic soda -- sodium hydroxide (from a chemist shop);
- * bowl;
- * barrel.

1. Chop the material up very finely.

2. To break down the fibres, boil the material in water.

3. Put the material through a meat mincer, or beat it with a smooth stone on a large rock to separate the fibres.

4. Leave for a day in a bowl of diluted caustic soda. Then, rinse thoroughly in cold water.

5. Put 1 part fibre with 20 parts water into a big container (e.g. barrel), and mix thoroughly.

Activity 5: Making paper

Now you are ready to make paper. You will need:

- * a flat dish or pan;
- * pulp (from Activity 2 or 3);
- * a fine wire mesh screen or an old net curtain stretched over an old picture frame, and secured with pins or tacks;
- * some sheets of felt;
- * a jar with a secure lid holding small stones, sand, dirt or water;
- * heavy weights (e.g. stones) and/or a clothes mangle (wringer) and hardboard.

1. Pour some pulp into the flat dish. (1)

2. Slide the wire mesh screen into the bottom of the dish, and scoop out some pulp. Spread evenly over the screen.

3. Lift the screen out carefully. Hold level, and let it drain for a minute. (2)

4. Lay the screen, pulp side up, flat on newspaper and place a damp sheet of felt over it. (3)

5. Gently turn the screen, pulp and felt 'sandwich' over so the screen is on top. Carefully lift the screen off, and then cover the pulp mush with another piece of felt.

6. Roll a jar full of stones, sand, dirt or water over the pulp 'sandwich' to squeeze out more water. (4)

7. Stack layers of felt and pulp 'sandwiches' alternatively. Then, put heavy weights on the pile to press out more water.

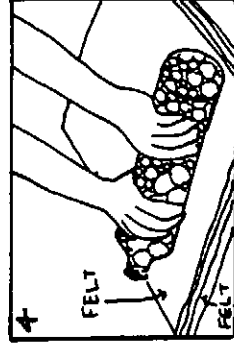
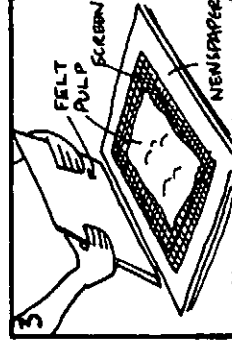
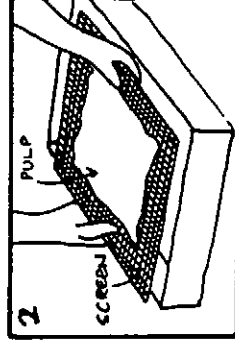
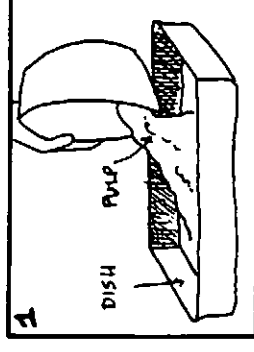



LEARNING-BY-DOING HEALTH & ENVIRONMENTAL ACTIVITIES FOR YOUNG SCIENTISTS LEAFLET NO. 86

3. Use long strips to make the sole. First make a 17 cm (7 in) fold in the first strip and gradually build up the base of the sole, packing the strips tightly together. Use the half strips to bind the sole together.

4. To add the strap, weave in a half strip. Adjust to fit your foot, and tape together. (A strip of stiff fabric may be even better.) Add a half strip which goes right around the sandal, viewed here from underneath.

5. To make the inner sole, draw the outline of the sandal onto a piece of cardboard, and glue in place to form the inner sole.

6. Finish the sandal off by wrapping a half strip round the outside of the sole and taping it in place.

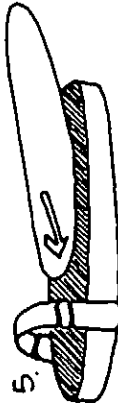
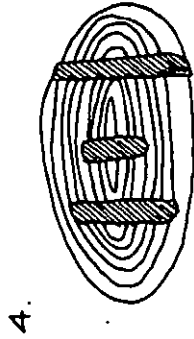
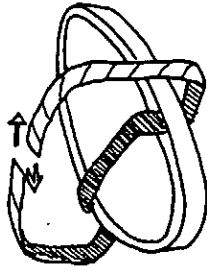
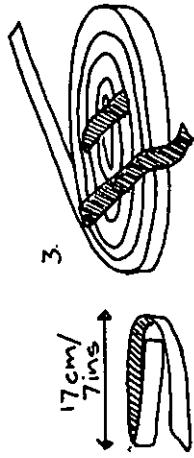

Activity 4: Testing the waste paper product

Now that you have designed and made your recycled product, it is important to test it. What you learn may mean you have to change the way you make the item. Or the data you collect may serve as marketing tools: "Guaranteed to withstand rain!"; "Egg cartons that can be used and used again!"

Think of ways to test the product. For example, you might want to see how well the newspaper sandals wear. Put them on (or have the wearer put them on) and walk a measured distance until the sandal starts to collapse, (this may take time!) Make two more pairs, and repeat this test. What is the average life -- or distance -- of a pair of sandals? You may also want to find out how the sandals hold up on different ground surfaces, or how they withstand rainwater.

Once you have a paper product that passes all the tests, you are ready to think about production and starting your own paper recycling business!

The paper sandals idea is taken from *Bother No. 136* Sept./Oct. 1985 "Do It Yourself - Recycling for a Fairer World" published by Oxfam, 274 Banbury Road, Oxford OX2 7DZ, United Kingdom. The material may be reproduced for non-commercial, educational purposes in low-income countries provided credit is given to Oxfam... Other sources of reference: Jon Vogler, *Work from Waste: recycling wastes to create employment* published by Intermediate Technology Publications Ltd. and Oxfam, 1981 (reprinted 1983), London: *Junior Projects No. 42 "Paper"*, published by Scholastic Publications Ltd. UK (1989).
OUTREACH pack 95 pp 11-12 Other Learning-By-Doing Leaflets and Information packs are available from Dr. James Connor, OUTREACH Director, Environmental Education Center, 200 East Building, New York University, New York, NY 10003 U.S.A. or Richard Lumbe, OUTREACH Coordinator, Information & Public Affairs, UNEP, P.O. Box 30552, Nairobi, KENYA

Making New Things From Old (2) Yesterday's News, Tomorrow's Shoes!

In low-income countries, more people are self-employed collecting waste paper and board for recycling than any other waste material. But what can the waste paper be used for?

In this leaflet, you will think of new uses for waste paper, and then carry out some experiments with different types of waste paper to find out which one has the necessary qualities for the new use. For example, you may decide you want to produce paper bags, and so you need a supply of waste paper that is strong enough to hold goods. This leaflet will also describe one way to recycle newspaper: you can try this yourself, and then test your new product.

New uses for used paper

You can make waste paper into new paper. This is explained in Leaflet no. 76. But there are plenty of other uses for waste paper. Here are some suggestions. Try thinking of some ideas of your own:

* **Animal bedding:** Shredded waste paper from offices can be used for bedding animals. One company that provides waste paper bedding claims pigs bedded on this material keep cleaner, chickens gain more weight and are less likely to die than birds bedded on wood shavings, straw or sand; other livestock have fewer breathing problems when bedded on paper instead of straw; shredded paper is much easier to 'muck out' from pens and stable after use. It spreads easily on fields and breaks down to form excellent manure.

* **Egg and fruit boxes:** You can create papier maché by boiling scrap paper in water, with some glue or flour until it becomes a thick paste. This paste can be shaped and moulded to make carriers for delicate farm produce.

* **Paper bags:** Waste paper can be used to hold nuts, sweets and other items of food.

IMPORTANT: If you use waste paper for the uses mentioned above, do not use waste paper which may have been in contact with poisons or disease. This would be a serious risk to health.

* **Building material:** All over the world the very poor use waste paper to construct their homes. Layers of waste paper and/or cardboard may be glued together to make walls, partitions and roofs.

Activity 1: Testing papers

Once you have thought of a new use for waste paper, you need to decide what qualities your waste paper product should possess. Then, you can find out which type of paper has these qualities. For example, any waste paper used as a building material needs, among other things, to be strong, and should not tear easily. It also needs to be able to resist water, and humidity. You need to devise ways to test paper. To do experiments, you will need:

- * samples of different kinds of paper of equal size: for example, newspaper; pages from a glossy magazine; a sheet of exercise book paper; computer printout paper, old envelopes; kraft sacks (large sacks or bags, often brown in colour); corrugated cardboard; grease-proof and cellophane paper. Remove staples.
- * various items for testing paper. This might include a bowl of water, a brick, staples and stapler, stiff card, rubber bands, a glass jar, clothes pegs, a ruler, cans of equal height, paper and pencil for recording results.

Here are three ways of testing paper:

(a) Testing paper for strength

What kind of strength should your paper possess - does 'strong' mean 'take a lot of rubbing' or 'doesn't tear easily'? Try the strength tests shown below, and grade the papers from strongest to weakest. Record your results.

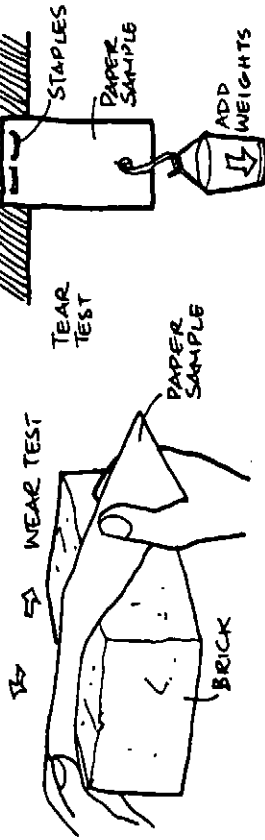

(b) Testing absorbency of paper

What are you going to measure, the height the water reaches in 30 seconds or how long it takes to travel 5 cm (2 in)? You could set up the test as shown below, and record your result. If you add dye or ink to the water, you can use the actual papers used in the test as a record by mounting them on the wall or on graph paper when the papers have dried out.

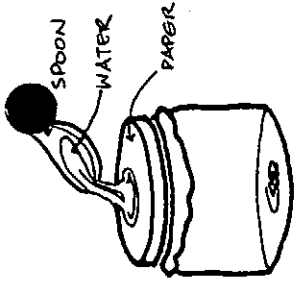
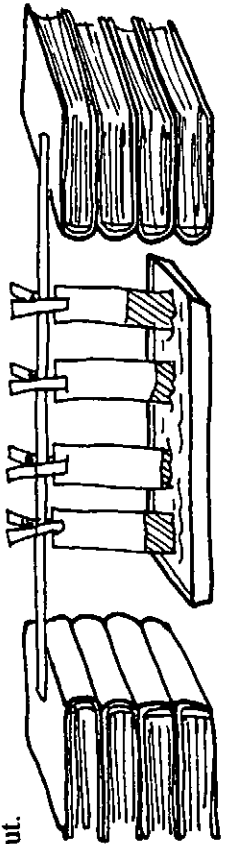

(c) Testing paper for water resistance

The picture at right shows one way to test resistance to water. To test the papers equally, you must make sure the same amount of water is applied in the same manner to each paper sample.

Activity 2: Make your recycled product.

Once you have measured all the papers for all the qualities needed to make your recycled product, study the results to determine which paper best meets the design criteria. Now you are ready to make the product. Think about what the product will look like: for example, if you are going to make a paper bag, will the bag have a flat bottom? Will it join at the side or the front? What glue will you use? Will the bag have cut-out handles or fix-on handles? And so on. Make the product, and then draw pictures to show how it was made. Make a list of the materials and tools needed to make the product. Explain where you can get all these supplies.

Activity 3: How to make thick-soled sandals from old newspaper

You can make thick-soled sandals from old newspaper. The instructions below are for size 8 (UK) feet (approximately 27.5 cm, 10³/₄ ins.). Use more or fewer strips for different sizes, but always begin with a 17 cm (7 in) fold. If your foot is too small, make a sandal to fit a grown-up in your household. You will need:

- * large sheets of newspaper
 - * cardboard
 - * sticky tape
 - * scissors
1. Take 9 large sheets of newspaper, and roll tightly to make 9 long strips.

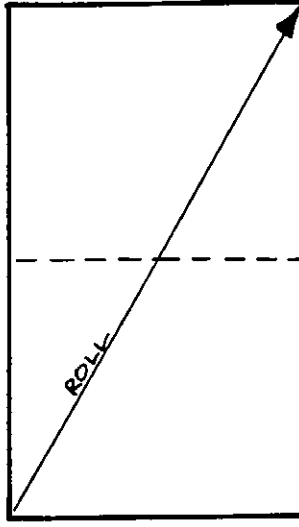

Flatten and tape.

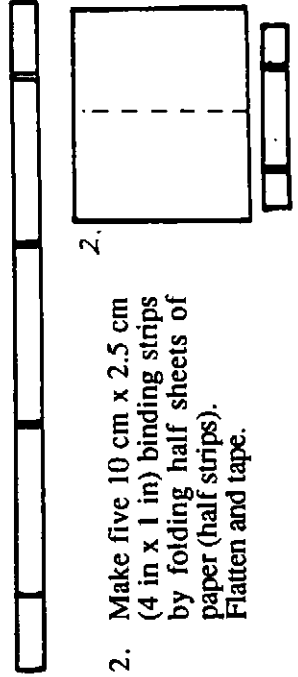

2. Make five 10 cm x 2.5 cm (4 in x 1 in) binding strips by folding half sheets of paper (half strips). Flatten and tape.



LEARNING-BY-DOING HEALTH & ENVIRONMENTAL ACTIVITIES FOR YOUNG SCIENTISTS LEAFLET NO. 87

1. Use caustic potash lye (from leached wood ashes) instead of caustic soda.
2. Use water from different sources to make the lye solution.
3. Make soap from just animal fat, soap from just vegetable oil, and soap from a mixture of both fats and oils.
4. After the lye and fats are mixed together, add a filler (e.g. sand, cornmeal or maize) or add an emollient (a softener or smoother such as vaseline or coconut oil).

Activity 3: Making soft soap by the hot method

Here is a recipe for making a larger quantity of soap that can be used for cleaning clothes, pots and general household purposes. You will need:

- * lye-water (as made in Activity 1)
- * a large cast-iron or enamel pot
- * a long wooden stirring spoon
- * a plate

1. Place the grease in the pot over a fire. Slowly pour in sufficient lye-water to melt the grease without burning. Stir constantly.
 2. Continue to add more lye-water a little at a time until all the grease has saponified. As the lye works to saponify the fat, the liquid becomes stringy and muddy-looking. Continue to add lye-water until the mixture looks like uniformly clear slime.
 3. If a thick scum of grease forms on top, the lye has been used up and more is needed to saponify the remaining fat. If the soap does not thicken and no scum appears, more grease is needed.
 4. To test whether the proper proportions of fat and lye are present, put a few drops from the middle of the pot on to a plate to cool. If it cools transparent with whitish streaks and specks, it is done. If the soap is grey and weak-looking or has a margin of grey around the outside, it needs more lye. If there is a grey skin over the sample, too much lye is present and more fat must be added.
 5. As the soap boils, a froth appears. This is a sign that water is evaporating. The soap must be kept over the fire until the water evaporates. When the froth stops rising, the soap falls lower in the pot. It is almost done. Large white bubbles appear on the surface, and make a peculiar sound as they pop. Now the soap is ready. Remove the pot from the heat and allow to cool in a place away from children and animals.
 6. Soft soap can be stored in a tight wooden barrel.
- Extension Activity:** Follow steps 1-4 in Activity 3. Then stir salt into the boiling soap. What do you see? What happens when the soap cools?

Sources of reference: Third World Science Unit, *Soap*, produced by Third World Science Project, School of Education, University College of North Wales, 1982; Phyllis Hobson, *Making homemade soaps and candles* (Garden Way Publishing, Vermont 1974); Marilyn Mohr, *The contemporary art of soap making* (Camden House Publishing, 1979); Mary Lynne Bowman and Herbert L. Coon *Recycling: Activities for the classroom* (ERIC Clearinghouse for Science, Mathematics, and Environmental Education, 1978).
OUTREACH pack 95 pp 13-14. Other Learning-By-Doing Leaflets and Information packs are available from Dr. James Connor, OUTREACH Director, Environmental Education Center, 200 East Building, New York University, New York NY 10003, U.S.A. or Richard Lumbe, OUTREACH Coordinator, Information & Public Affairs, UNEP, P.O. Box 30552, Nairobi, KENYA

Making New Things from Old (3) Turning Grease and Dirty Ashes into Clean Soap

If you've seen the fats from meat trimmings - tallow from beef and mutton or lard from pork and bacon - have you ever thought of using it to help get your clothes clean? It doesn't seem possible, does it? But these leftover fats, together with old ashes from wood stoves, can be made into soap. This leaflet describes how to make soap.

IMPORTANT: A grown-up needs to supervise all the activities. Please read instructions before beginning activities.

Activity 1: Preparing the soap ingredients

There are only three ingredients essential to making soap: grease (fat), lye and water. Other ingredients are added to give certain desired qualities to the soap.

(a) Water.

The quality of the water is important. Rainwater is ideal as it is relatively pure.

(b) Fats

Save grease and fats from meat trimmings and other sources. Vegetable oils, such as coconut or palm oil, can be used, too. Even rancid oils will make perfectly good soap. It's a good idea to mix poultry fats and vegetable oils with tallow and lard rather than use them alone.

Old grease needs to be clean before being used to make soap. Cut the fat into small chunks, and melt slowly over a low heat. Strain the melted grease through layers of cheesecloth, and squeeze as much grease as possible out of the scraps. Clean the melted fat by adding water and bringing it to the boil. Keep boiling for 10 minutes. Remove from the heat. As it cools, the fat forms a layer on top of the water and impure ingredients. When the fat hardens, turn it over and scrape the impurities from the bottom of the cake, and repeat if necessary.

(c) Lye

Lye is any strong alkaline solution. You can make caustic potash lye from wood ashes or buy dry lye flakes (usually caustic soda or sodium hydroxide).

WARNING: Lye is a caustic substance. If mishandled it can burn skin or even cause blindness. If lye solution splashes onto your clothes or skin, wash with diluted vinegar, and then wash with plenty of water for 15 minutes. Keep lye away from children and animals. Lye also corrodes aluminium, so use only enamel, iron, or earthenware containers. Add lye only to cold water. Adding lye to hot water might cause a violent chemical reaction. When dissolved in water, lye produces dangerous fumes.

To make lye from wood ash, you will need:

- * a large earthenware or iron pot with a hole at the bottom
- * an enamel or iron pot
- * straw
- * wood ashes
- * rain water
- * uncooked, raw potato
- * spoon

1. Put the earthenware pot with a hole in the bottom on a stand, as shown in the picture. Place an enamel or earthenware pot beneath it.
2. In the pot, put some straw to act as a filler.

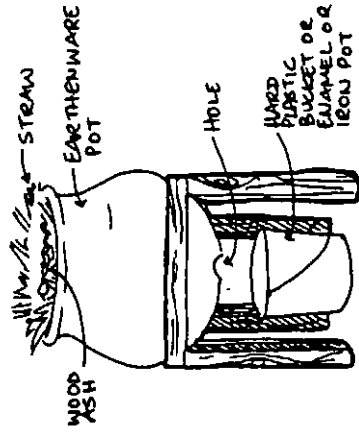

3. Fill the pot with wood ashes. Press down. Add more ashes.
4. Scoop out a depression in the middle of the wood ash, and fill it with water (preferably hot water). Add cold water. As the water is absorbed by the ashes, the ashes settle down. Add more ashes to the pot. Lye-water drips through the straw and out of the hole in the earthenware pot into the enamel pot beneath. The longer it takes for the water to drip through the ashes, the stronger the lye-water will be.
5. Use a spoon to put a raw potato in the lye-water. If the potato floats, the lye is ready for use. If the potato sinks, the lye is too weak.
6. Potash can be made by boiling down the lye-water in a iron pot. After the water has been boiled away, there remains a dark, dry residue which is known as 'black salts'. Maintain the heat until the black impurities melt and burn away. The greyish-white substance that remains is potash. Store what you don't use in an airtight container out of reach of children for the next time you make soap.

Making soap

To make any soap it is necessary to mix diluted lye or lye-water with fat or oil and stir until *saponification* takes place. Saponification is the chemical reaction by which the two ingredients -- lye-water and fat -- are converted into one substance -- soap.

There are two methods of making soap: the cold process and the hot process. If lye-water and fat are mixed when they are cold, the process of saponification may take several days or even months, depending upon the strength and purity of the ingredients. But if the ingredients are boiled, the

process of saponification takes place in a few minutes or few hours.

The hot and cold methods can be used to produce two different, but similar products, soft soap and hard soap. Soft soaps are thick and creamy and do not harden. Hard soaps can be poured into moulds to set.

Activity 2: Making hard soap by the cold process

Here is a recipe for making a plain white all-purpose soap that can be used for washing your face, your clothes and general household purposes. You will need:

- * 120 ml (1/2 cup) cold rainwater
- * approx. 28 gms (2 tablespoons or 1 oz) lye flakes (sodium hydroxide)
- * 240 ml (1 cup) clean, melted tallow (beef fat)
- * two enamel, iron or earthenware containers (*not* aluminium ones)
- * a wooden spoon
- * vinegar (to have handy in case you get lye on your skin or eyes)
- * soap moulds capable of holding 360-480 ml (12 - 16 ounces) of liquid soap. Shallow cardboard boxes make good moulds.

1. In one container, pour the rainwater. Slowly add the dry flaked lye, stirring constantly with the wooden spoon until the lye has dissolved. (*Always add lye to water, never add the water to lye because it will explode.*) In the other container, put the melted tallow.
2. Set aside both solutions to cool to lukewarm. Test the temperature by feeling the outside of the containers. *Do not touch the solutions themselves.* The solutions may take an hour or two to cool.
3. While the solutions are cooling, prepare the moulds. You can line the mould with a damp cloth or 2 layers of damp brown paper to prevent the hardened soap from sticking to the mould.
4. When the lye-water and fat are lukewarm, pour the lye slowly into the fat, stirring constantly and in the same direction. Bring all the lye into contact with tallow. What happens?
5. Continue stirring until the mixture thickens. The amount of stirring required depends upon the temperature of the solutions and can therefore not be predicted. It can be as short as five minutes or as long as an hour. Ten to thirty minutes is common.
6. To find out if the mixture is ready for pouring, take a spoonful, and holding it about 4 cm (2 inches) above the mixture, dribble a ribbon of soapy mixture onto the mass. If the ribbon remains separate and does not immediately merge with the rest, the soap is ready to pour into the moulds.
7. Pour the mixture slowly and evenly into the moulds. Allow to set. The soap must not cool too quickly. When it has a firm butter-like consistency, slice the soap into bars if necessary. When the soap is fully set (and saponification is complete) then can it be removed from the mould.
8. It should then be left in a cool place to cure for several weeks. The finished product should be smooth and white.

Extension Activities: On the next page are some variations to the above experiment which you can try.



LEARNING-BY-DOING HEALTH & ENVIRONMENTAL ACTIVITIES FOR YOUNG SCIENTISTS LEAFLET NO. 88

Making New Things from Old (4) Soap Suds

All new products -- including those made from recycled materials -- should be tested to find out how well they work. Leaflet no. 87 'Making New Things from Old (3) Turning Grease and Dirty Ashes Into Clean Soap' describes how to make different soaps by recycling fats and wood ashes. Follow these instructions carefully to make several different soaps. Once you have done so, you can investigate which of the home-made soaps works best, and if your products are more desirable than commercial soaps made from new materials.

Activity 1: Why we need soap

Before testing soaps, it is important to understand what soaps are for. To do this, try this simple experiment. Take an old, dry cloth, and rub a little dirt or dust onto it. How can you get rid of the dirt? If brushing it off doesn't work, you may find that washing the cloth with water alone will do the trick.

But now mix a little grease with dirt, and rub it onto the cloth. Will water alone remove it? No: This is because water does not usually mix with oil or grease. Water just slides along the oil, and cannot grab onto it to wash it away.

That's where soap helps out. Molecules that make up soap can "latch" themselves onto both oil and water. Then, extra water washes the "attached" water and dirty oil away.

Why is grime on clothes usually oily? Where does the oil come from? Your body! Your skin gives off oil all the time. Oil from your scalp mixes with dirt in your hair. Dirt gets on your clothes and mixes with oil from your skin. Soap is needed to remove the dirt and oil.

Activity 2: Which soap mixes oil and water best?

You know that soap helps to mix water and oil, two liquids that usually do not mix together. In the following experiment, you can discover which of your soaps does this best. You will need:

- * a jar with a lid for every soap
- * a grater
- * some vegetable oil
- * sample plus one extra jar
- * home-made and commercial
- * a measuring spoon
- * some water

5. As soon as the shaking is complete, rest the jar on a table and immediately measure the height of the bubbles in the jar. You can use tape to mark on the outside of the jar how high the bubbles reach in the jar, see picture. Record your result on a chart similar to the one below.
6. What happens to the bubbles or suds when the sudsing mixture is allowed to stand for 10 minutes? Record the effect. What happens after an hour?
7. Repeat steps 3 - 5 for each soap sample. Each jar should be given the same number of shakes, or shaken for an equal amount of time.

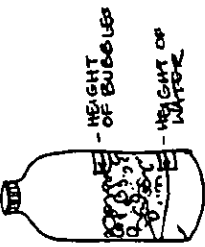

Height of bubbles (a) when stopped shaking (b) after 10 minutes (c) after an hour	Mixtures			
	soap A	soap B	soap C	soap D

8. Which soap produced the most bubbles? Was your prediction correct? Compare suds from your home-made soaps with suds produced by commercial soaps.

Extension Activity: Compare the suds of the same soaps but mixed with water from different sources -- rainwater, spring water, well water etc. Does the source of water have any effect on the amount of suds produced when each soap is mixed with it?

Activity 5: Market research

Now you have completed some laboratory tests, it is now time to do some 'market research'!

If you normally use commercial soap to wash the household clothes, switch to the home-made soap for a period of time. Afterwards, ask your family members if they have noticed any difference in the look, smell or feel of the clothes they are wearing? (Do the clothes look cleaner? Smell more pleasant? Feel softer? Irritate the skin? And so on.) Do members of your household prefer clothes washed in commercial soap or in your home-made variety? Why?

Do you think it is makes sense to produce soap for your family on a regular basis? Consider:

- * the effort needed to make the soap;
- * the availability of the ingredients - the recycled materials;
- * the cost savings of not having to buy commercial soap (if soap is normally bought);
- * the satisfaction shown by the 'consumers'.

Some of the activities were adapted, with permission, from *WonderScience* magazine, Vol. 6 No. 7 November 1992 on "soaps and detergents". Copyright 1992, American Chemistry Society. Another source of reference: A. Harris Stone and Benjamin M. Seigel, *The Chemistry of Soap* (Prentice-Hall Inc, 1968).
OUTREACH pack 95 pp 15-16. Other Learning-By-Doing Leaflets and Information packs are available from Dr. James Connor, OUTREACH Director, Environmental Education Center, 200 East Building, New York University, New York NY 10003, U.S.A. or Richard Lambie, OUTREACH Coordinator, Information & Public Affairs, UNEP, P.O. Box 30552, Nairobi, KENYA

1. Place 120 ml (1/2 cup) of water in each jar. Into all but one of these jars, add 30 ml (2 level tablespoons) of one soap sample. The soap sample may be in the form of a liquid or a grated solid. Stir the soap in the water until they are well mixed. Why is it important to mix equal amounts of soap in equal amounts of water?
2. Mark all the jars with a letter code. For example, give the letter code 'A' to the jar with just water; letter code 'B' for the soap solution made from animal fat and lye from wood ashes; letter code 'C' to a soap solution made from animal fat and lye made from banana skin ashes, and so on. (These codes may be used throughout the experiments in this leaflet.)

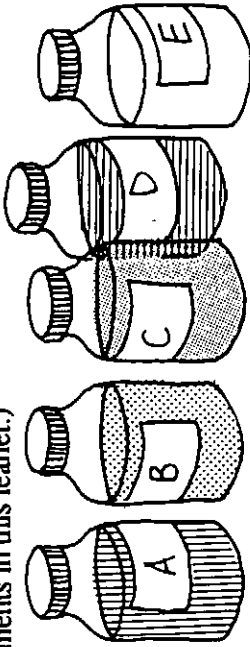

3. Add 30 ml (2 tablespoons) of oil to each jar. Secure the lids on all the jars.
4. Shake jar A vigorously three or four times. Let the water settle. Do the oil and water mix or do they separate?
5. Follow Step 4 using each of the other jars that contain home-made soap samples. Which soap seems to make the water and oil mix best? Which soap would you choose to clean up grime?
6. Try this experiment using several kinds of commercial soaps to compare home-made soaps with soaps that you can buy.

Activity 3: Which soap is the best at attacking grime?

You will need:

- * plain paper;
- * some wax paper;
- * some dirt mixed with, say, a little mashed banana;
- * stirring stick;
- 1. Repeat steps 1 and 2 from the previous experiment.
- 2. Divide the piece of paper into as many columns as you have soap samples plus one extra column. In each section, write the letter code of water or soap sample. Cover the paper with wax paper.
- 3. Make a streak of dirt/banana mix on the wax paper. It should run across all the columns. Use your finger to smooth the streak so that it is the same thickness throughout. Why does it have to be the same thickness?
- 4. Use straws to put a drop of liquid from each of the jars onto the dirt/banana streak in their particular column. Leave for 3 to 5 minutes. Why do you think it is important to use the same amount of soapy liquid to remove the same amount of dirt?

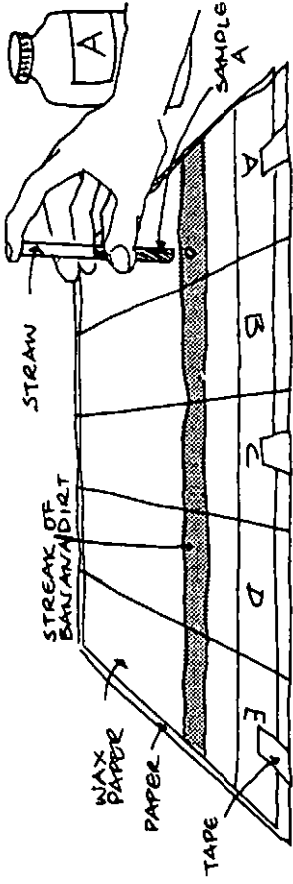

5. Place the wax paper in a thin stream of tap water. Which liquid cleaned the wax paper best? Which cleaned it worst? Record your results on a chart similar to the one shown below.
6. Try a similar experiment using a dirt/greasy mix on an old, white rag. Record your results.
7. Try a similar experiment using dirt/grease on your fingers. Record your results.

Best cleaner for removing dirt/grease from:	soap A	soap B	soap C	soap D	soap E
	(1) wax paper				
(2) cloth					
(3) fingers					

Extension Activity: Test the cleaning power of your soaps on other types of dirt and on other surfaces. In every test use the same amount of water and the same amount of soap to remove the same amount of greasy dirt.

Activity 4: Measuring suds

An important quality of soap is how many suds they make, and how long the suds last. Suds help spread the soap so more of the soap molecules can work on the greasy dirt. Which of your soaps is the sudsiest? To find out, you need:

- * a large jar with a lid
- * a grater,
- * for every soap sample
- (each jar should be of equal size);
- * measuring spoons;
- * water,
- * watch/clock.
- * tape;
- * pencil;
- * watch/clock.

1. In each jar place 60 ml (1/4 cup) of water and 15 ml (1 level tablespoon) of one soap sample. The soap sample may be in the form of a liquid or grated solid. Secure the lids onto all the jars.
2. Mark all the jars with a letter code as described in Activity 2 step 2.
3. Guess which soap sample will make the most bubbles. Record your prediction.
4. Shake one of the jars vigorously to mix the water and soap and produce bubbles.



LEARNING-BY-DOING HEALTH & ENVIRONMENTAL ACTIVITIES FOR YOUNG SCIENTISTS LEAFLET NO. 89

Making New Things From Old (5) Making a Living from Paper Bags

Being able to make new things from old is not enough to ensure success in a recycling business. There are many other issues to consider. Three of the most important questions to ask yourself before you set up a business are:

- * Is there a big enough - and regular - supply of scrap and other raw materials?
 - * Are there plenty of people willing and able to buy your product?
 - * Can you make enough money from the business to buy all that is needed to survive?
- This leaflet will help you to think about some of these issues through an example of a paper-bag making business.

In Calcutta, many families are homeless because they cannot afford to rent a one-roomed shack in the *bustees* (shanty-towns). The children have to find, or create, work to survive. One means of doing this is paper-bag making. The children tear up old exercise books or used newspaper to make the bags, which they then sell to shop-keepers or street vendors.

Activity 1: How to make a paper bag

Bags are made by folding and gluing. Make one yourself. You will need:

- * various types of scrap paper (e.g. newspapers, used computer paper from a local business, old exercise books from school - with the teacher's permission!)
- * glue

1. Fold sides of paper to middle.
2. Glue down one edge, and stick down overlapping edge.

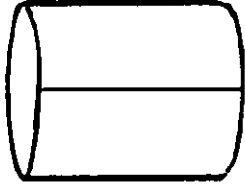
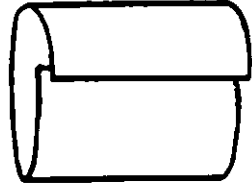

From your discussions with shop-keepers, how many bags would you need to make to satisfy demand? Are you able to make enough bags to meet this demand? What would you do if you (a) couldn't make enough bags, or (b) could make many more bags than are needed?

In Calcutta, the going rate for paper bags is about 10 paise per bag. There are 100 paise in 1 Rupee (₹1). How many bags would need to be sold to make a rupee? If you could earn the same amount per bag, how much money could you earn in (a) a day? (b) a week (c) a month?

If you know what the going rate for paper bags is in your community, work out how much money you could earn in (a) a day, (b) a week and (c) a month.

Activity 5: Material source

If you think there is a demand for paper bags in your community, you would need to have access to a regular and reliable source of raw materials for your paper bag enterprise. This is something you would have to explore by asking local households, stores, schools or offices about the availability of their supplies of scrap paper.

Activity 6: Can you make enough for you and your family to live on?

You know how much money you can earn, but is this enough to live on? Draw up a list of items you and your family need to buy in order to survive. This list would probably include rent, food and fuel for cooking. What else would you need to buy? On the list note the prices of these items. Calculate the amount of money you and your family need to survive for (a) a day (b) a week (c) a month.

What income does your family already earn? How much more money do you need to make for your family to survive? Can you earn this money from paper bag making? Look at the results of Activity 4 to find out how much money you could earn in one hour from paper bag making. Divide the amount of money you still need to earn by the hourly rate from paper bag production to find out how many hours you would need to work in this recycling business. Can you make enough for you and your family to live on by making paper bags?

If you cannot make enough money to survive, think about how you can improve the business to make more profits.

Think about what other recycling business you could start. Use this leaflet as a guide to work out if such a business is a way of making enough money for you and your family to survive.

This leaflet has been adapted from information in "The Paper Bag Game", a simulation game about poverty issues in Calcutta, published by Christian Aid. For further information, write to: Christian Aid, P.O.Box 100 London SE1 7RT United Kingdom
OUTREACH pack 95 pp 17-18. Other Learning-By-Doing Leaflets and Information packs are available from Dr. James Connor, OUTREACH Director, Environmental Education Center, 200 East Building, New York University, New York NY 10003, U.S.A. or Richard Lumbe, OUTREACH Coordinator, Information & Public Affairs, UNEP, P.O. Box 30352, Nairobi, KENYA

3. Turn up bottom edge about 5 cm (2 inches), crease and unfold.

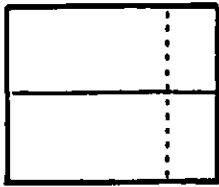

4. Fold up bottom corners to the crease.

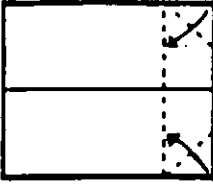

5. Press down and crease.

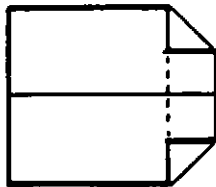

6. Unfold.

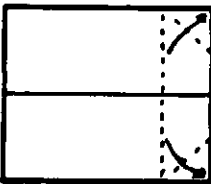

7. Tuck the corners up inside the tube.

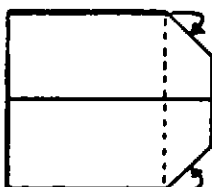

8. Now you have a bag with two flaps, A and B.

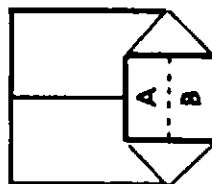

9. Fold back the upper flap, A.

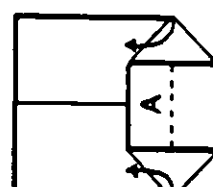

10. Fold down on itself to the middle line, C.

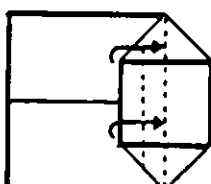

11. Paste edge where shaded.

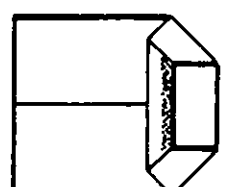

12. Fold up the lower flap, B, to overlap with the glued area and stick down.

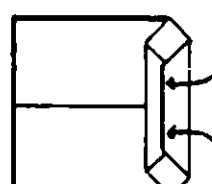

- * Try making a variety of bags:
- * of different sizes
- * from different types of paper,
- * using different amounts of glue.

Label each completed bag with a number or letter. Measure the size of each bag, and then record the following information on a chart:

Bag	Material	Final Size	Amount of glue used
1	newspaper	20 cm x 30 cm	two brush strokes
2	computer paper	15 cm x 25 cm	four brush strokes
3			

Activity 2: Market research

In Calcutta, children sell the bags in batches of ten to local shopkeepers. If you were to sell paper bags, who do you think might buy them? What would the bags hold? Get some ideas by asking local shopkeepers or street vendors if they use or need bags, and what they might use them for.

Find out how much the vendors are willing to pay for the bags, and how many they would buy each week or month. They may want to buy them in batches of, say, 10 or 100. If they already use bags, try to find out what they are currently being charged.

Activity 3: Which bag is the one to make?

Gather some possible contents and test the bags to find out if they are large enough or strong enough to hold these goods. For example, if the bags may be used for holding rice, have a quantity of rice available for testing the bags' strength. Make sure you have clean hands when handling food.

Design and try out your own strength test, but be sure to treat all bags equally, and record your methods and results. One tip for this experiment: spread out a large cloth over which you load up your bags. If and when bags burst, the spilled contents can be collected, counted or weighed, and kept clean.

Which bag is most suitable for holding the goods? How much paper do you need to make this bag?

Activity 4: Meeting demand

You have your product, so now you need to think about production. With plenty of paper and glue at your finger-tips, find out how many bags you can make in 20 to 30 minutes. Then, complete the chart below. (Any sub-standard bags will be rejected by shopkeepers, so do not include these in the calculations.)

No. of bags made in ___ minutes: _____

No. of bags possible in 1 hour: _____

No. of bags possible in a 40-hour week: _____

Paper needed for one week's work: _____

TEACHER'S NOTES FOR LEARNING-BY-DOING LEAFLETS ON WASTE AND RECYCLING

The Learning-By-Doing leaflets in this pack are intended for middle and high school students under the direct supervision of adults. OUTREACH cannot be held responsible for any accidents or injuries that may result from conducting the activities without proper supervision, from not specifically following directions or from ignoring cautions included in the text.

LEAFLET NO. 81: WHAT A WASTE!

TEACHER'S TIPS

- In this leaflet, students will
- * define waste, including hazardous waste and litter;
 - * gather and analyse survey data on household waste;
 - * develop measuring skills;
 - * develop observation skills;
 - * recognise the health risks of waste.

Introduction

You can introduce the topic by asking the question: "Who knows what waste is?" A useful definition is "material that has been discarded because it is worn out or is no longer needed". For more specific definitions, see box below.

There may be divergent opinions as to what constitutes waste. One person's rags may be another person's recyclable blanket. People in richer nations may view a worn-out tyre as waste, but people living in poorer regions may

Some definitions of waste

Solid waste: Any unwanted material, either solid or semi-solid, that is discarded from households, industries or communities. This may include trash, old appliances, cars, ashes, human waste, construction debris, industrial chemicals and by-products etc.

Hazardous waste: Waste materials which are dangerous to living things or the environment because they have one or more of the following characteristics:

- * poisonous
- * unstable (explosive) or radioactive
- * corrosive (capable of dissolving flesh or metal)
- * flammable (readily burnable)

Litter: Waste materials which are carelessly discarded in an inappropriate place.

see its potential as a feeding trough for animals or as a harness for work animals, and so on. Also what is thought of as waste may vary over time. For example, the once waste products of the pulp and paper industry are now a source of fuel and chemical feed for animals. It should be noted that the term 'waste' is not just associated with solid waste: it may also refer to unused land or contaminated water.

List all the words students use to define waste. Then, explain that the focus of this leaflet is solid waste. While much hazardous waste is in a solid or semi-solid state, it is not generally considered part of the solid waste stream, and so is not within the scope of this leaflet. While human waste is one form of solid waste, it will not be covered in this pack. (For more on human waste see OUTREACH issues 12 - 14 on Waste and Sanitation and issue 76 on Appropriate Water Technologies.)

Ask students: What are the names used to describe solid waste? (e.g. waste, litter, garbage, rubbish, refuse, etc.)

What kind of waste materials do we throw away at home, at school? (Write them on the blackboard.)

Activity 1: A survey of household waste

This activity should be undertaken by students at home only if they have all the necessary equipment and their parents give permission. If household surveys are not practical, you could either:

- a) bring in waste from your own home for students to measure and analyse; or
- b) carry out this exercise with waste generated in the school.

Depending upon the age and skills of your students and upon availability of equipment, collected waste may be measured by volume and/or by weight. The leaflet describes how to compare types of waste by volume. If spring

scales are available, waste can be sorted by type, placed in separate bags and weighed. The weights can be recorded. Invite students to rank waste materials in order by weight, from the heaviest to the lightest. Have students compare weight and volume rankings.

Activity 2: Studying waste in your neighbourhood

This activity is intended to make students more aware of the amount of litter that clutters the environment, especially in urban areas.

It would be helpful for your students to have already studied the life-cycles and habits of disease-carriers such as flies and mosquitoes before starting this project.

This activity may be conducted as a class activity. The students may produce one large map of the locality.

For practical purposes, you may split the class into small groups, each of which should have paper and a pencil. Then, divide the survey area into separate study sites, and assign each one to a particular group of students. In its survey site, each group should carry out all the tasks described in the leaflet.

Before on-site visits, ask your students to list the sites where they think waste will be found. This will not only help define the area to cover, it will also establish how observant they are. If you want the survey to be followed by a clean-up project, it may be a good idea to focus survey work on a specific site. Help your students select an area that is safe from traffic and that they can manage to clean up easily.

Walk around the neighbourhood with your students, and if necessary prompt their observations with questions. (For example, ask them where they think flies and mosquitoes might breed.) Supervise their on-site work in case hazardous materials have been dumped at the location. Always make sure they wash their hands thoroughly after the activity.

Once students have gathered all their data about the sites, they may prepare a report on their findings. The results may be presented to the community so that local people become more aware of how much litter exists in their community, and the eyesores and health hazards that are thus created. The students may prepare an account of the waste survey for the local newspaper or they may organise a local exhibition of their findings.

Activity 3: Tackling Waste

This section offers suggestions to students for putting their survey results to practical use.

Activity 4: Are you a litter-bug?

This activity helps students realise how litter-conscious they are. Your students should adapt this questionnaire to make it more appropriate to local conditions.

If students have truthfully answered the questions and discovered that they are litter-bugs, they should be encouraged to think about why and how they might change their attitude and behaviour.

EXPERIMENTAL RESULTS

Activity 1: A survey of household waste

The results of this survey are going to vary quite dramatically from country to country and from town to country. An American's pile of rubbish would probably dwarf that of someone from, say, Sri Lanka, and the contents of a town dweller's pile would likely include more packaging and convenience items than the rubbish pile of a person from a remote farming community. Have students discuss these variations. Wealth, lifestyles, wasteful use of resources, durability of products and packaging are some of the issues that might arise in their discussions.

ANSWERS TO QUESTIONS

A survey of household waste

Measuring objects by volume is a useful way to assess the amount of litter the students collect, especially as litter, if collected, is usually put into dumps or landfills. Encourage students to be creative in their suggestions for measuring volume. A simple way is to place waste into standard-shaped containers, such as cardboard boxes, and then multiply the number of filled containers by the volume of the containers.

GOING FURTHER

Spread the message about litter

Invite your students to tell local residents about the consequences of putting garbage on the streets to rot. Through plays, posters and litter clean-up campaigns, students can draw

attention to health risks. Health risks include skin disorders from handling waste and diseases spread by flies and mosquitoes that breed on waste sites.

Students may encourage others to become involved in clean-ups and in maintaining a litter-free neighbourhood.

Tons of Trash

The world has a growing garbage crisis. All of us contribute to it, but some contribute more than others! Here are two mathematical exercises that may help students become more aware of the global waste problem.

The chart below shows the amount of waste generated in selected cities around 1980, and the cities' population at the time. Complete Chart 1.

a) In the early 1980's, which city generated

the most waste/least waste per person? How many times your weight in rubbish was thrown out by residents in these cities? Approximately, how much waste did each of these cities produce in one year? Which of the cities mentioned in the chart produced the most waste? Why is this figure only approximate?

2. Chart 2 shows the type of waste thrown away by residents in four major cities of the world. Make a bar chart or pie diagram of each city's waste. Compare the charts/diagrams of the four cities. What makes up the largest part of urban waste in New York? In Singapore? In Medellin? In Calcutta? Can you explain these answers? If you were in charge of waste disposal in these cities what methods would you recommend?

City	Population (1980)	Waste generated circa 1980 (kgs/person/day)	Waste generated circa 1980 (in '000 tonnes)
	A	B	$A \times B \times 365/1,000$
New York (USA)	16,573,600C	1.8	
Hamburg (Germany)	1,653,043 (79E)	0.85	
Singapore	2,600,000E	0.87	
Bandung (Indonesia)	1,462,637C	0.55	
Medellin, (Colombia)	1,477,000(79E)	0.54	
Calcutta (India)	3,291,655(81C)	0.51	

(Population figures for cities not metropolitan areas, E = Official estimate, C = Census, () = year if not 1980)
 (Source of waste figures: Sandra J. Cointreau, *Environmental Management of Urban Solid Waste in Developing Countries* (Washington, D.C.: World Bank, 1982))

Material type	Cities			
	Brooklyn, New York, USA	Singapore	Medellin, Colombia	Calcutta, India
Paper	35	43	22	3
Glass	9	1	2	8
Metals	13	3	1	1
Plastics	10	6	5	1
Leather and rubber	X	X	X	X
Textiles	4	9	4	4
Wood, bones, straw	4	X	X	5
Nonfood total	74	63	34	22
Vegetative and putrescible	22	5	56	36
Miscellaneous inerts	4	32	10	42
Compostable total	26	37	66	78

Source: Sandra J. Cointreau, *Environmental Management of Urban Solid Waste in Developing Countries: A Project Guide* (The World Bank, Washington, D.C., 1982) Table 3, p.14
 Notes: Figures may not total due to rounding; X = not available

LEAFLET NO. 82: DANGER! HAZARDOUS MATERIALS SPREAD THE MESSAGE NOT THE WASTE!

TEACHER'S TIPS

- In this leaflet, students will
- * learn about the characteristics of hazardous material and hazardous waste;
 - * learn to recognise products that contain hazardous materials;
 - * explore how design and colours are used as a symbol language to communicate an idea;
 - * appreciate that at present there is no safe disposal method for hazardous waste, and that reduction of hazardous materials is the only long-term solution;
 - * Investigate safer alternatives.

It would be useful if students have studied acids and bases before starting this leaflet.

Introduction

Before and during work on this topic, have students cut out articles from newspapers which relate to hazardous material/waste. Also have students listen to television and radio news for reports of incidents or concerns regarding hazardous materials/wastes. Take a few minutes each day to share their findings. Discuss the types of hazardous material/waste that are reported on (e.g. radioactive, industrial, agricultural, household waste etc.) Please note that radioactive and industrial wastes are not covered by this leaflet.

Encourage students to share stories about people they know who have been injured by hazardous materials (e.g. pesticides).

Activity 1: What are hazardous materials?

You may want to bring samples of hazardous household/farm products into class. To avoid students handling hazardous materials, collect 10 to 15 containers of household materials and take the following precautions before allowing students to study them:

- * Make sure the containers are empty, and tape the lids shut. (Do not wash out the containers.)
- * Wrap each container in a clear plastic bag and tie off at the top. This will protect students from any chemicals that may have

dripped down the side of the containers.

- * Explain to students before they study the containers, the potential seriousness of the topic.

Household items that you might bring in to study and that students might list as hazardous include the following:

Cleansers:

air freshner, bleach, scouring powder, rug cleaner, detergent, disinfectant, drain cleaner, oven cleaner, dry cleaning fluid, furniture polish, spot remover.

Work materials:

Paint, paint thinner, furniture stripper, turpentine, petroleum, kerosene, glue.

Pesticides:

Fungus killer, weed killer, insect killer, wood preservatives, rat poison, moth balls, chemical fertilizers.

Automotive products:

motor oil, transmission fluid, brake fluid, antifreeze, car batteries

Others:

medicine*, shoe care products, cosmetics, refrigerant, batteries.

* You might need to explain that medicines can be hazardous if they are misused.

Activity 2: Warning labels

You might want to introduce this exercise by asking students to name frequently-used designs that represent ideas. (Students might think of road and traffic signs, and designs used to represent countries and holidays.) Have students develop associations related to the symbols. Then, show some symbols for hazardous materials, such as those depicted below, and discuss what associations students have with these symbols:



Students may work in groups to design labels. Once labels are completed, have the groups test out the effectiveness of their labels on other schoolchildren.

Here is another exercise to do related to labelling:

Be a label detective

Divide the class into small groups, and provide each group with the following:

- * an empty container of a household hazardous material. Make sure the container is empty, that the lid is taped shut (do not wash out the container), and that the container is wrapped in a clear plastic bag and tied off the top so that students are protected from any chemicals that may have dripped down the side.
- * pencil and paper

Have the students answer the following questions:

1. What is the name of the product?
2. What is the product used for?
3. What are the active ingredients?
4. Write down all the instructions that explain how the product should be used.
5. Write down all the warnings that help protect people's health and the environment.
6. What directions are given about how the container should be disposed of?
7. Is there any other helpful information on the label?
8. Can you think of any other information that should be included on the label?

Once the students have done the exercise, discuss in class what information should be on a label, and what is unnecessary. (Remind students when they design labels that the products might be used by people who cannot read.)

Activity 3: When do hazardous materials become hazardous wastes?

Have your students brainstorm a list of the most common waste products (e.g. paper, plastic, metal, glass, used batteries, old paint, pesticide containers etc.) Which of these waste products do the students think are hazardous?

Have the students find out how hazardous materials in their homes are disposed of. Discuss in class the potential dangers of these disposal methods. (For further information on (a) disposal methods, see OUTREACH issue

no. 92; on (b) hazardous materials, see OUTREACH issue 94).

Oil leaking from tankers is one hazardous waste that is often in the news. But much oil pollution comes from municipal run-off and industrial waste. At an individual level, used oil from cars drips onto roads and into the ground. It gets into water and harms living things. Try the class experiment, "Cleaning Up Oil Spills" (OUTREACH issue 94, page 26).

Using safer alternatives

Many students might be unfamiliar with hazardous commercial products: their households may be using home-made cleansers and natural methods for controlling pests. Discuss the safe methods and materials they use in their home, and encourage their use.

Activity 4: Making a household cleanser

Encourage students to use the basic non-toxic cleansers, but do stress the importance of handling the materials with care, and of not mixing compounds. Have students follow the directions to make an all-purpose cleanser. Make sure they use gloves or use thick plastic bags to cover their hands.

Have the students test for the presence of a base (alkali) in the common non-toxic cleansers. They will find that many cleansers are basic.

Activity 5: Testing safer household cleansers

Encourage students to predict the outcome before attempting the experiment. Make sure experimental conditions are similar for all trials (i.e. the cleansers are applied in the same way to the same amount and type of dirt/grease on the same type of surface).

EXPERIMENTAL RESULTS

Activity 5: Testing safer household cleansers

Water is likely to be the least effective. (Try both cold and hot water if possible.) Vinegar cuts grease, while baking soda softens water and serves as a good scouring powder. The cleaning solution containing ammonia cuts heavy grease and grime.

ANSWERS TO QUESTIONS

Activity 1: What are hazardous materials?

(1) chlorine bleach, (3) glue, (4) paint are hazardous materials. (2) vinegar is not harmful, though it is not advisable to drink in any quantity.

Activity 2: Warning labels

A3; B4; C1; D2.

It is important to keep dangerous substances out of the reach of children who might tamper with the products and try to eat or drink the material without realising the dangers.

GOING FURTHER

Safer alternatives for controlling garden pests

The leaflet focuses upon safer alternatives to commercial household cleansers, but you can also investigate safer alternatives to commercial pesticides for getting rid of garden pests.

Natural pest controls are cheaper and safer for health and the environment, and they usually control specific pests without harming other living things.

Discuss with your class what is meant by effective protection against garden pests. Your definition might be the absence of insect intruders or the absence of damage to plants.

Here is an experiment your students can try in order to find a safer alternative to chemical pesticides. In this experiment, students will try to discourage an insect attack on a plant by spraying it with strong-smelling or strong-tasting substances, such as garlic, onion, hot peppers, herbs or spices. (Insects often identify their favourite food plant by smell.) Have the students use a variety of substances in solutions to increase the chance of hitting the right combination.

For the experiment, students will need:

- * strong-smelling or strong-tasting plant material (e.g. garlic, hot peppers, onions, herbs or spices etc.);
- * water;
- * a container for spraying;
- * containers for crushed plant material;
- * a measuring jug;
- * equipment for crushing plant material (e.g. a knife for cutting, and a mortar and pestle or two stones for grinding materials);
- * strainer;
- * sticks for labelling.

1. Crush the plants separately. Measure out various combinations of crushed material, recording the quantities in each mixture on a chart similar to the one shown below.
2. Mix equal amounts of these combinations with equal amounts of water, and allow to soak in separate containers for at least one day or until the water has picked up the aroma or taste. It will aid the experiment if the water is warm or if the mixture is boiled. Strain to collect the liquid.
3. Spray each solution onto two or three affected plants of the same variety. Label plants that have been sprayed.
4. Observe which combination provides the best protection. Record the results on a chart similar to the one below.
5. Repeat the experiment, using the same combinations of plant materials, but steep the solid material in less water, and then in more water. Which combination of plant material offers the most effective protection against pests? Observe what happens after rain has fallen.

Extension: A very mild soap and water spray (no bleach or detergents) can also be used successfully on most insect-infested plants. Try adding some soapy water to the strong-smelling solutions you have been using to find out if the soap makes the solutions more effective.

<i>Ingredients in combinations and their quantities</i>	<i>Quantity of water</i>	<i>Name of plant sprayed</i>	<i>Insect pest</i>	<i>Observations</i>

To conduct the experiment, the class may be divided into smaller groups with each group testing one of the formulas. Have the students try out their natural pest controls on plants growing in the school garden so that the growing conditions for all the plants tested are the same. The class can then discuss all the results to determine the most effective pest control.

Other natural methods of pest control are described below. Carry out experiments to test their effectiveness:

- (a) Sprinkle wood ash on the ground near plants. The ash traps crawling insects by clogging their pores and the insects die.
- (b) Encourage creatures such as insect-eating birds and toads into the garden to help insect populations down. Bring toads into the garden, and keep them there by providing them with a cool, shady place to live, such as a small box or a shelter made

of twigs and plants. Toad homes should be in a quiet area of the garden.

- (c) Barriers of heavy paper, metal cans with both ends removed, or stones sunk 5 cm. (2 inches) into the earth around the base of a seedling may prevent cutworms from getting to the stem. Cutworms are grubs that live just under the soil surface and can kill seedlings by cutting through their stems.
- (d) Small amounts of beer can be placed in shallow containers around the garden to attract snails or slugs.

For more information on pests and pest controls, see OUTREACH issue nos. 30-31, and Learning-By-Doing leaflet no. 21 on insect pests. Also refer to *School garden manual* by Marny Smith and June Plecan (produced by Save the Children, 54 Wilton Rd. Westport, Connecticut 06880 USA, 1989)

LEAFLET NO. 83: THAT'S ROT!

TEACHER'S TIPS

In this leaflet, students will

- * investigate how different materials decompose;
- * predict and observe changes to decomposing materials;
- * make and test hypotheses regarding the variables that might speed up decomposition;
- * design a container in which materials decompose fast;
- * apply their conclusions to assess the effectiveness of a local rubbish dump for decomposing materials;
- * assess their local dump in terms of its environmental and health impact;
- * be introduced to terms such as decomposition, biodegradable, variables, landfill, leachate.

Decomposition

Decomposition is the process by which materials break down. Air, water, sunlight and other agents break down inorganic, or non-living, materials such as rocks and metals. Living organisms, such as moulds, bacteria,

fungi and other microbes, break down organic materials such as food waste, wood, dead animals -- materials that come directly or indirectly from other living things. Materials that are broken down by living organisms are said to be *biodegradable*.

Just about anything is degradable and will eventually break down, given the proper conditions and enough time. In the chart below there is a list of materials and the times they take to break down completely, as long as they get air and light. (Times will vary depending upon conditions. For example, moist, warm conditions are likely to speed up

How long does it last?	
Item	Time taken to break own completely
aluminium can	350 years
egg shells	6 months
leather shoes	40 years
tin can	100 years
milk carton	5 years
newspaper	6 months
cigarette filter	10 years
wool sock	1 year
some plastics	400 years

decomposition of organic materials.)

When an organism dies, it is broken down by a succession of living things. Initially, scavengers, such as beetles, might feed on the dead organism. Later decomposers such as bacteria and fungi, break down the material further. As these organisms consume the organic material, they produce waste products that serve as nutrients for plants and other living things. This is a very efficient process of disposing of waste -- all the materials are recycled. (Warm, moist and well-aerated conditions are ideal for most decomposers. Certain organisms can biodegrade organic material in the absence of oxygen, but the process is very slow.)

Activity 1: What rots?

You can start with an open-ended question, "What do you think makes things rot?". While you might expect answers such as "light", "air" and "water", be prepared for original replies, and be willing to put these original ideas to the test.

You may find it easier to conduct this -- and subsequent -- experiments as class or group activities rather than individual exercises. This way, less equipment is required, teamwork is emphasised, and safety rules can be more rigorously supervised. For example, fewer plastic bags will be needed, and as those used will need to be safely disposed of after the experiment, there will be less waste created. Bags containing materials that do not change in this experiment may be used in future experiments. If decomposing materials are handled by the students, they should wear plastic gloves. If gloves are not available, students can wear plastic bags over their hands, fastened at the wrist with a loose rubber band.

Have class discussions after each experiment so that each group has an opportunity to explain the methods chosen, the variables that were tested, and the results. Have students share results for comparison, and then each group can decide for itself how to proceed with the next experiment.

Activity 2: Aids to decay

In this experiment, variables are factors that influence how things rot. The only bag students may have difficulty preparing is the one with water: they may find it hard to tie the

bag. Supervision may be required.

Activity 3: Make a 'rotting pot'

The leaflet suggests that the student create a single rotting pot. However, it might be best to divide the class into groups, and encourage each group to test out different techniques for including variables that speed decomposition.

A clear plastic soda container is suggested for the container, as this may be punctured to allow exposure to air. (If a plastic bottle is not available, the students could try using a glass jar. Holes in the lid would allow materials to be exposed to the air.) The soda top would have to be cut off so that the waste materials can be placed inside. Use a sharp blade (e.g. a razor) to slice almost all the way around near the top of the bottle. Leave a flap of about 3 cm (1 in.) After filling the pot, it is recommended that you flip the top back on and seal with tape. Sealing containers keeps in moulds, microbes and smells.

Activity 4: Investigate your local rubbish dump

Much of the rubbish that is collected ends up in open dumps or in landfills.

A landfill is a depression in the ground that is filled by trash. The garbage is spread out and compacted daily, then covered with a layer of dirt or plastic. Landfills create less of a health hazard than open dumps, in which garbage is neither compacted nor covered, but both have their share of problems. While the problems of litter, odours and rodents have long been appreciated, the serious problems of leachate and methane produced at landfills and dumps have only been recognised comparatively recently.

Leachate is a solution formed as rainwater percolates through a landfill. The water is slightly acidified by biochemical processes so that it readily dissolves or leaches various substances present in waste. Some of these, particularly some of the metallic elements, are toxic and pollute ground water when leachate flows out of a landfill and into soil. When dumps and landfills have been built on wetlands, gravel pits and other areas with porous rocks, the problem of leaching is especially acute.

Methane (CH₄), a colourless, combustible, and potentially explosive gas, is produced by

bacterial decomposition of the waste. It permeates the landfill, and frequently seeps into adjacent land and buildings where fires and explosions occur. Methane can kill vegetation by reducing oxygen in the soil.

Another problem of landfills is that many of the biodegradable materials that were believed to decompose in a landfill -- don't. Garbage scientists, called garbologists, have uncovered 50-year old carrots, newspapers and other "biodegradable" items that are still intact. These items have not decomposed because oxygen, which bacteria and most decomposers need, does not penetrate the compacted layers of a landfill.

In some countries, state-of-the-art landfills have been carefully designed to eliminate environmental problems that have plagued early ones. Siting is restricted to geologically-suitable areas. To try to prevent leachate and methane from leaving the landfill, the bottom is covered with an impermeable liner usually made of layers of clay and synthetic materials.

When students try this investigation, they can simply focus on the conditions that promote speedy decomposition, or they can do a broader survey which looks into the environmental health and safety issues related to waste dumps.

As students are likely to touch waste when they explore a dump, have them wear gloves (or plastic bags on their hands secured at the wrist). Make sure they wash their hands after any site visit.

EXPERIMENTAL RESULTS

Activity 1: What rots?

Changes the students may observe: newspaper starts to yellow; leaves start to brown; moulds grow on food scraps and rust appears on some metal scraps.

Students are not likely to observe changes in the following items: notebook paper,

pencil, key, plastic and sock.

Results between groups are likely to differ. Have the students discuss why there are differences: were bags exposed to the same light, the same temperature, the same amount of water? Through discussion, students should start thinking about different variables that might influence how things rot.

Activity 2: Aids to decay

Effects of variables on banana peel are likely to vary but here's what students might find: banana peel in soil rots best, with mould developing; peel exposed to light grows greenish-brown mould in spots, white mould on shady side; the fleshy part of the peel swells up and curls in water; peel dries out in air; in the control bag, peel develops mould on the fleshy side, and black spot on the other.

Other variables students may think of testing might include adding salt or vinegar, or introducing creatures such as worms or ants.

Activity 3: Make a 'rotting pot'

Results will vary as students introduce different variables in a variety of ways. In general, food and organic farm waste rots quickly (within a few weeks), but no change is seen in soda tabs or plastic items. Contents exposed to air and light are likely to show more signs of decomposition than those that are not. Lots of air bubbles may appear when a sealed pot full of water is shaken. This suggests a gas is being made.

If students record the temperature of the contents of their 'rotting pot' over time, they will notice the rotting material gives off heat.

Activity 4: Investigate your local rubbish dump

What data is gleaned depends upon the skills of the students and the cooperation of dump owners and workers. Results will vary.

LEAFLET NO. 84: SIFTING SCRAP

TEACHER' TIPS

- * In this leaflet, students will
- * investigate the properties of certain materials;

- * predict and observe how materials behave;
- * develop problem-solving techniques when separating different materials;
- * communicate ideas for a recycling centre.

Activity 1: Scrap properties

Paper, plastic, glass and metal each has its own way of being recycled, so each needs to be separated from the others before recycling. To be able to do this, students need to understand that each type of material has its own physical properties. For example, steel is magnetic, and glass is heavier than plastic or aluminium. Have students consider behaviour of materials in different circumstances. For example, does heavy paper behave differently from less heavy paper? Does paper or aluminium foil behave differently if it is first crushed into a ball? The differences between the materials will be exploited by the students.

In this activity students should be encouraged to try out their own methods to discover the different properties of scrap materials. So while four tests are suggested, these should be undertaken only after students have exhausted their other ideas. Working in groups is helpful: not only does this reduce the amount of equipment required, it also encourages peer discussion. Try to gather as much and as varied testing equipment as possible beforehand so that students are limited only by their ideas and not by practical considerations.

When conducting experiments, always encourage students to predict results before carrying out the exercise, and then compare predictions with actual results.

Activity 2: Sorting the scrap

Encourage the students to use their

imaginations to devise a mechanical system for separating waste materials. The students should be warned that this exercise might involve a lot of trial and error on their part.

One way that may help students organise their thoughts is for them to create a flow chart to show what materials they start out with, how each material is separated, and which materials are left after each step. After the experiments, it may look something like the flow diagram shown below.

Activity 4: Design a recycling centre

It might be a good idea for students to have tried Learning-By-Doing leaflets nos. 26-28 on inventing before they try activity 4.

Students can try this activity in groups, and their final efforts can be presented to the school and community. Invite local entrepreneurs, and local community leaders to attend.

EXPERIMENTAL RESULTS

Activity 1: Scrap properties

Students will identify various properties depending upon the tests that they perform on their materials. In the suggested tests, students use magnetism, static electricity, density differences and air movement to separate materials.

Magnets only attract metallic objects, but not all metals. Magnets attract metals made of iron, steel (an iron alloy), cobalt and nickel. They also attract so-called tin cans because these are made of steel lightly coated with tin.

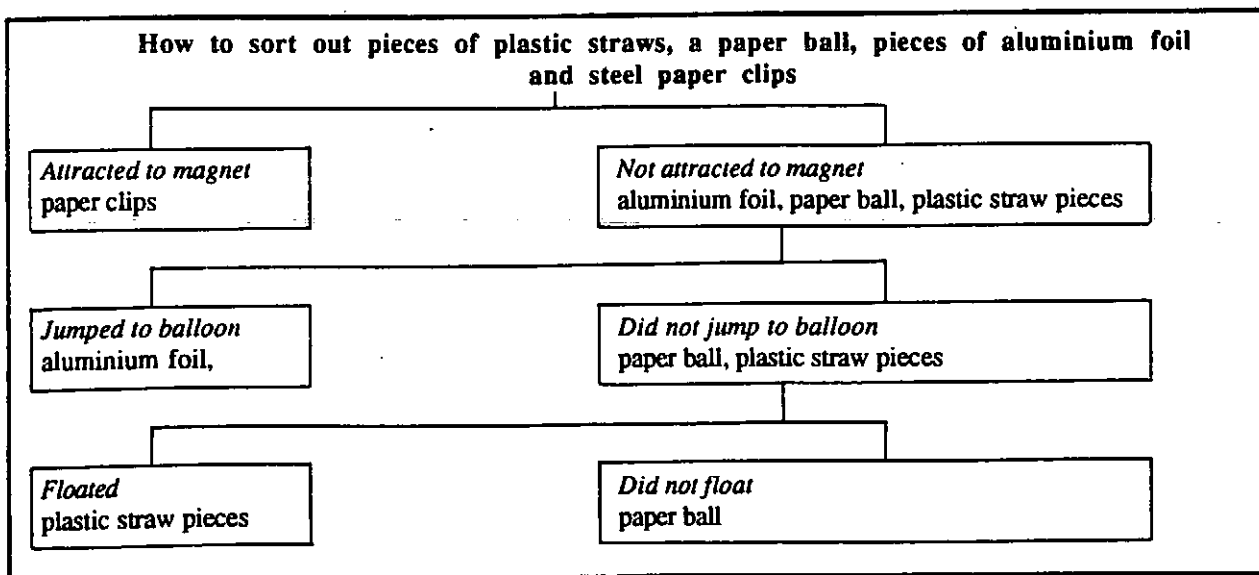

At a recycling centre, magnets can sort steel beverage cans from aluminium ones.

Fans can separate lighter (less dense) objects from heavier (more dense) ones. The strength of the air movement will determine which objects can be separated by this means.

Static electricity can be used to separate aluminium foil from the other materials.

Test (d) is a way of discovering which objects sink and which float. Of the materials being tested, plastic straws float, and the paper and metals sink.

Activity 2: Sorting the scrap

How the students separate the scrap materials will vary depending upon the properties of the materials that students decide to focus upon. One possible way of separating the materials is to use a magnet to separate

metal paper clips; static electricity to separate aluminium foil pieces; and water to separate floating plastic from sinking paper balls.

Activity 3: More challenges

A piece of sticky tape may be used to collect rubber bands; gentle gusts of air may be sufficient to separate wood shavings from a pile of scrap; glass marbles may be separated by shaking the pile of scrap materials and allowing the marbles to roll away. While these methods are sufficient to separate these particular items, have students think about the general characteristics of the materials. For example, one characteristic of glass that may be exploited is that it shatters into pieces. (Plastic on the other hand may be easier to crush but it does not shatter.)

LEAFLET NO. 85: MAKING NEW THINGS FROM OLD:

(1) A PAPER CAPER and

LEAFLET NO. 86: MAKING NEW THINGS FROM OLD:

(2) YESTERDAY'S NEWS, TOMORROW'S SHOES

These two leaflets explore ways to recycle paper. Issue no. 85 looks at how to make new paper from waste paper, and issue no. 86 explores other ideas for paper products made from used and recycled paper.

TEACHER'S TIPS

- In these leaflets, students will
- * learn how to make new paper from used paper;
 - * investigate factors that affect the quality of recycled paper;
 - * design and conduct quality control tests on waste paper;
 - * learn how to make newspaper sandals;
 - * undertake product testing.

Leaflet no. 85 Activity 1:

Looking closer at paper

Have students collect and display all of the different types of paper that they can find around the home and school, see box: *Types of Waste Paper*. Discuss what the students will accept as paper, and have the class try to list its properties. Have the students describe the various paper samples (e.g. colour, texture etc.). Have them tear and study the papers' fibres.

Leaflet no. 85 Activities 2 - 4:

Making pulp

You can organise these activities by dividing the class into small groups, and have each group make pulp from different raw materials. A group may be allocated one of the following tasks:

To make pulp from:

- 1) old newspaper without anything added, torn into big/small pieces and soaked for a short/long time;
- 2) old newspaper with cornstarch added, torn into big/small pieces and soaked for a short/long time;
- 3) old newspaper with orange peel added, torn into big/small pieces and soaked for a short/long time;
- 4) substitute used exercise paper for newspaper in 1 - 3 above;
- 5) cotton rags;
- 6) wood shavings;
- 7) leftover crops.

Types of Waste Paper

Different types of waste paper are listed below, starting with the most valuable waste paper and going on to those of less value:

1. *Computer printout paper* (printing does not reduce its value)
2. *Computer punched cards* (sometimes called tab-cards)
3. *Printers' trimmings* - leftovers when a printer has cut paper products.
4. *Office papers* - Invoices, ledgers, letter-papers, record cards, etc. Those printed on should be separated from blank papers, and white papers should be separated from coloured ones. Envelopes can be mixed with white papers. Carbon papers, self-duplicating paper, metal file clips, string and staples should be removed.
5. *School and letter-papers*. Letter-paper may be of good quality, but school exercise book papers are low in value, although they often contain only a little ink which increase their value.
6. *Pamphlets and magazines* (known in the trade as Pams). The lowest grade of printing papers other than newsprint. They are often coated, have heavy printing and large amounts of colour.
7. *Kraft sacks*. Kraft paper is recognised by its strength and brown colour. It is used for large sacks, in two or three ply thicknesses, or for smaller bags and wrapping papers.
8. *Corrugated cardboard*. This is brown board made of three layers. The flat top and bottom layers are called liners and the corrugated (wavy) centre is the fluting.
9. *Newspaper*.
10. *Mixed waste paper*. This is the lowest value paper, and may have almost any composition. This is the material often collected from municipal (town) refuse by scavengers on rubbish dumps or at specially built composting or refuse sorting plants.

Source: Jon Vogler, *Work from Waste: Recycling Wastes to Create Employment* (published by Intermediate Technology Publications and Oxfam (reprinted 1983), available from IT Publications, 103-105 Southampton Row, London WC1B 4HH, United Kingdom.)

After the students have made their pulp, each group should show/describe its pulp to the class. Encourage students to use their senses to describe the pulp in terms of colour, consistency, smell. (Students should not taste or expose skin to the pulp because of residue ink dyes and caustic soda.)

Leaflet no. 85 Activity 5:

Making paper

Each group can use the pulp it has made to make paper. Once all the groups have made paper, have the class brainstorm ways to compare the qualities of the different groups' paper products. For example, each group could observe and record what happens when a drop of ink is placed upon its paper. (Refer back to students' list of paper qualities in Activity 1, and read leaflet no. 86 for other ideas for testing paper.)

Have each group conduct tests on its recycled paper, and present their findings to the class. If possible, groups should recommend uses for their recycled paper.

Leaflet no. 86: New uses for used paper

The leaflet invites students to think of new uses for waste paper, to determine the necessary qualities for the waste paper product, and then to experiment on a range of papers to determine which type of waste paper best meets the design criteria.

To do this, students need access to a variety of paper types, see box: *Sources of paper*. You can also make use of paper that students have made from waste paper (in leaflet no. 85).

The activities may be partly performed by the class as a whole (brainstorming new paper uses and necessary paper qualities) and then the class may be divided into groups to test papers to find which has the necessary properties. Techniques and results may then be pooled at the conclusion of the project. Alternatively, the whole exercise might be carried out in groups.

If you have access to only a limited waste paper supply, you may divide the class into groups, and give each group a supply of paper with a challenge to think of a way to recycle the paper. Each group would have to investigate the qualities of its paper supply, and then think of a new use for it. When students investigate the qualities of waste paper, they should be encouraged to play with the paper.

Leaflet no. 86 Activity 4:

Testing the waste paper product

Encourage the use of words such as 'model', 'prototype', 'first stage' and 'finished product'.

Sources of Waste Paper

Computer offices create the most valuable of all waste paper.

Printing shops usually sell the trimmings themselves or else they are collected by merchants.

Newspaper presses almost always sell the edge-trimmings and reel-ends themselves.

Offices throw out quantities of blank paper as well as office records, letters, etc. If offices are small or located away from the city centre, they may not have made arrangements to sell their waste.

Warehouses and factories receive goods in sacks and cartons, and often discard these after unpacking. Quantities may be large.

Shops receive goods in cartons but supermarkets and food stores often give or sell these to their customers.

Householders may allow their servants to sell any waste paper. It may be dirtied by food waste or ashes and not be in large quantities to make it worthwhile collecting. However, thousands of people in many countries make a living by collecting household waste paper, sometimes paying the householder a small sum.

Refuse dumps receive paper that no-one has thought worth collecting, even though quantities of good quality waste paper are found on dumps all over the world.

Source: Jon Vogler, *Work from Waste: Recycling Wastes to Create Employment* (published by Intermediate Technology Publications and Oxfam (reprinted 1983), available from IT Publications, 103-105 Southampton Row, London WC1B 4HH, United Kingdom.)

Once students have designed and tested their product, have them think about the mass production of the paper goods. The students will need to determine where to get supplies, and sort out how production should be organised (i.e. the order of the processes -- cutting, gluing, etc.) Leaflet no. 89 explores some of these issues further.

EXPERIMENTAL RESULTS

Leaflet no. 85 Activities 2-4: Making pulp

The results will vary depending upon the type of paper used and the process adopted. In activities 2 and 3, students produce mechanical pulp and in Activity 4 students make pulp through both mechanical and chemical means. A description of mechanical and chemical pulp is given below and is based upon a description

in Jon Vogler's book, *Work from Waste: Recycling Wastes to Create Employment* (published by Intermediate Technology Publications and Oxfam (reprinted 1983), available from IT Publications, 103-105 Southampton Row, London WC1B 4HH, United Kingdom.).

"*Mechanical pulp* is made by pounding or grinding cellulosic material such as wood. A characteristic of paper made of mechanical pulp is that it is very weak and loses its strength altogether if wetted. Mechanical pulp is ideal for newspapers because it is highly absorbent and liquids, such as printing inks, are soaked up and dry very quickly. Mechanical pulp often contains tiny particles of wood which have not been reduced to fibre and are visible to the naked eye. Thus paper made from mechanical pulp is often described as 'woody'.

Using *chemicals* in the pulping process is a way of pulping cellulose fibres and not have them weakened by mechanical pulping. Wood or stalks are mechanically reduced to small chips and then cooked at high pressure with certain chemicals that attack the bonds between the fibres and release them to form pulp. The most common chemicals used are:

(a) caustic soda and sodium sulphate which produce coarse, very strong fibres known as Kraft, suitable for sacks and boxes to hold heavy weights, and

(b) various sulphites (such as ammonia and calcium) which produce fine fibres suitable for making good quality printing and writing papers."

There are many variations to pulping processes, and under supervision, students should be encouraged to experiment. For example, if the pulp is made from newsprint or other paper with print, then the pulp is likely to be greyish in colour. Adding cornstarch makes the pulp smoother and more stable.

Leaflet no. 85 Activity 5: Making paper

Results will vary. Students' recycled paper is likely to be much thicker and rougher than recycled paper made at a paper mill which is smoothed and flattened by all kinds of machines.

LEAFLET NO. 87: MAKING NEW THINGS FROM OLD
(3) TURNING GREASE AND DIRTY ASHES INTO CLEAN SOAP
and LEAFLET NO. 88: MAKING NEW THINGS FROM OLD
(4) SOAP SUDS

These two leaflets look at soaps made from recycled materials. Leaflet no. 87 explores how different soaps can be made from leftover fats and the ashes of wood or banana skins. Leaflet no. 88 describes tests that can be conducted on soaps, enabling comparisons to be made between home-made soaps and ones produced commercially. The soap-making activities are appropriate for older secondary students, while all other activities may be conducted by primary and secondary students alike. All soap-making activities should be well supervised by a responsible adult.

In these leaflets, students will

- * produce an alkali by leaching;
- * make various soaps by a chemical process called saponification;
- * understand such terms 'solution', 'soluble', 'solvent' and 'suspension';
- * learn what is meant by alkali and acid;
- * compare cleaning abilities of different soaps;
- * explore the concept of controlling variables.

One way of introducing the topic of soap might be to ask the class: "Have you ever wondered *why* we need soap?" A student's answer may well be, "To get clean!" Persist with your questions, "But why isn't water good enough to clean our bodies and our clothes?" and invite the class to discover why by trying the simple experiment outlined in Activity 1 in leaflet no. 88.

It would be useful for students to have studied alkalis and acids and have an understanding of hazardous materials prior to working through these leaflets.

Safety measures

Soap-making is easy, but the ingredients are hazardous. Young children and animals should be kept away during the soap-making process, and older students should be warned about the dangers of working with the ingredients.

In all the soap-making experiments, students should be well-protected from the ingredients. Lye, for example, is a caustic substance. Once the chemical reaction, saponification, has taken place, the material will not be as caustic. If mishandled, lye can burn skin and even cause blindness. So eyes should be protected from lye fumes and splashes, and rubber gloves should be worn to

protect hands from accidental splashes of lye. If possible wear a long-sleeved shirt, long trousers and shoes. Do not wear shorts or be in bare feet when making soap

In view of the caustic nature of lye and the necessity of using heat in these experiments, it is important to supervise the soap-making process. In fact, the leaflet should be conducted as a class activity for younger students. With older students, the preparation of soap ingredients and the soap-making processes (Leaflet no. 87 Activity 2 and Activity 3) could be conducted as a class experiment, too, while the various extension activities could be divided among several student groups. Each group would still require adult supervision, however.

Equipment for soap-making

- * *A large iron, enamel, hard plastic, stainless steel or earthenware pot.* A large pot is important to reduce the risk of ingredients splashing over. Aluminium or tin pots must not be used because the lye will corrode these metals.
- * *A large wooden spoon.* Wood is preferable to metal because the handle will not conduct heat as rapidly. The spoon should be large, as a small spoon puts your hands much too close to the hot mixture.
- * *Soap moulds.* No special soap moulds are necessary. Any shallow pan can be used. Cardboard or wooden boxes can be used. Match boxes provide miniature soaps.

Saponification

If students have studied acids and bases, they know that an acid will react with a base to produce a salt and water. When a fatty acid reacts with a potassium or sodium base, it forms a salt which is soap.

The fats or oils used to produce soaps are mixtures of fatty acids and glycerine. Lye is a strong alkaline solution. Examples of lye are caustic soda (sodium hydroxide) and caustic potash (potassium hydroxide). When lye and fat are combined, a chemical reaction takes place. This reaction has the technical name of saponification. What happens is that the lye separates the fat into two components, glycerine and the fatty acids. The potassium or sodium in the lye then combines with the fatty acids to form potassium or sodium salts of these fatty acids. These salts are what you want. They are the soap. The reactions that take place can be expressed as follows:

Fat → Glycerine + fatty acids

Fatty acids + Lye → Potassium or sodium salts of fatty acids (soap)

The base called caustic potash (KOH) is obtained from wood, plantain (e.g. banana) peel or cocoa pods. A characteristic of potassium soap is that it has a soft consistency. Potassium soaps are mild and good for the skin, but they are too soft for most uses of solid, or hard, soap. To make hard soap, it is necessary to replace the potassium base with a sodium base. The most common is sodium hydroxide or caustic soda (NaOH). Both caustic soda and caustic potash are corrosive and hygroscopic (absorbing moisture from the atmosphere).

To sum up, soap-making is nothing more than a process of converting insoluble fats into water-soluble detergents. Lye is used because it accomplishes this.

There are two methods for making soap: the cold process and the boiling process. Both methods can produce soft soap and hard soap. Soft soaps have saponified when they are thick and creamy with a slightly slimy texture. They do not harden, and are ready for use at this stage. Uncooked hard soaps are ready to be poured into moulds when the emulsion has thickened to the consistency of honey. Boiled hard soaps have saponified when the mixture is thick and slides off the spoon.

Leaflet no. 87 Activity 1: Preparing the Ingredients

(a) Water.

The quality of water used is important.

Rainwater is relatively pure, and therefore ideal for soap-making. Water that contains a lot of calcium and magnesium is called hard water. This water should not be used for soap-making, because when these minerals are present in the lye solution, they form calcium and magnesium salts of the fatty acids instead of potassium or sodium salts. Potassium or sodium salts (or soap) are soluble and so form good suds. But calcium and magnesium soaps are insoluble, and therefore do not form suds. This can be expressed thus:

Soap + hard water → insoluble calcium and magnesium salts of fatty acids (no soap)

Hard water is formed when rainwater percolates through ground that contains calcium or magnesium minerals. The water leaches out these minerals. To find out if spring or well water is hard, you can conduct a hardness test on your water. A very simple test is: does soap lather easily when washing? A more rigorous test is described below.

Hard water test

Make a solution of pure soap in 120 ml (1/2 cup) of wood (methyl) alcohol. Add the soap a little at a time until the solution is as strong as possible without thickening when stored at room temperature from day to day. Select two small identical capped containers. Fill one half-full with rain water. Fill the other half-full with water to be tested. The amounts must be equal. Using an eye-dropper or straw, add the soap solution, one drop at a time, to the rain water bottle. After each addition, shake vigorously to produce suds. Continue to add soap solution until enough suds are formed to cover the surface of the water for one minute when the bottle is laid on its side. Record the number of drops used.

Add the same amount of drops of soap solution to the bottle of water being tested. If it produces the same suds, the water is soft. If sufficient suds do not form, add more soap solution until suds are produced, identical to the rainwater test. The amount of extra soap solution used represents the amount of soap wasted each time the water is used for washing. For instance, if twice as much soap solution is required to produce equivalent suds, it means that for all the soap you add to water to wash clothes, half the amount is used to soften the water and half the amount is used to wash the clothes.

(b) Fats

To produce clean, white odourless soap, the fats must be fresh. Cooled, hardened tallow can be stored: it will stay sweet at cool temperatures for several weeks. Do not store where it can absorb strong odours such as onion.

Fat may contain unpleasant odours which can taint the finished soap. Potatoes cooked in the grease will absorb most of the smells. This should be done before "washing" the fat. Tallow which is rancid or smells a little off can be sweetened by heating it with a lemon or vinegar solution. 30 ml (2 tablespoons) of lemon or vinegar dissolved in 120 ml (1/2 cup) of water and boiled with 240 ml (1 cup) of fat will improve its character for soap-making.

Make sure all specks of blood and meat have been removed before cleaning the fat. A strainer, cheesecloth or any coarse cloth can be used to strain the fat. Each 450 gm (1 lb) of trimmed beef fat yields at least 240 ml (1 cup) of strained rendered tallow. Pork fat may yield up to twice as much. Tallow cools to a hard consistency somewhere between the spongy softness of lard (pork fat) and the brittle hardness of mutton fat.

(c) Lye

Directions are given for preparing lye from wood ash. When water is added to wood ash, it leaches out the alkali, especially potassium hydroxide. (You could explain to students that leaching also occurs when rain percolates through soil and washes valuable minerals down through the soil.) Wood ashes can be used again to make lye, but the lye will not be as strong the second time. Compare lye-waters by testing the pH value.

Have older students try to produce lye from the ashes of other plant leftovers, such as banana skins or cocoa pods. For example, burn banana skins until they form a black ash.

Crush this black ash into a powder, and heat it as strongly as possible so that the ash begins to glow. Continue heating until the ash turns white. Use this white ash instead of wood ashes to make the lye solution.

Commercial lye comprises sodium hydroxide, otherwise known as caustic soda. It is generally made by the action of lime on a boiling solution of sodium carbonate. The resulting flaked lye is both convenient and efficient with the added advantage of producing consistently good results. Be sure to purchase only dry flaked lye. Commercial lye flakes must be treated with extreme caution. A flake of lye mixed with perspiration can sear the skin. In solution they cause acute, painful burns.

Leaflet no. 87 Activity 2:

Making hard soap by the cold process

Cold process soap-making requires accurate measurement. The class will make only a small amount of soap in this activity, but it is important to master the process and become familiar with the ingredients before going on to making larger quantities of soap. The chart below provides a simple guide to measurements for larger quantities (the fats should be melted first then measured).

Do not rush the cooling process of the lye-water and the fats. When mixing lye into the fats, do it little by little and slowly, stirring all the time. Bring all the lye into contact with the fat so that no free alkali or fat remains.

If the stirring seems to be taking a long time, the ingredients were probably too warm when added together. Set the pot in cold water and continue to stir. The outside edges may then cool faster than the inside mixture, causing a crust to form. If this happens, remove from the cold water and stir vigorously to disperse the lye.

Ingredients for making soap

<i>fats</i>	<i>lye</i>	<i>water</i>
240 ml (1 cup)	28.3 gm (2 tbsp.)	120 ml (1/2 cup)
480 ml (2 cups)	85 gm (1/4 cup + 2 Tbsp.)	180 ml (3/4 cup)
1.2 litres (5 cups)	142 gm (1/2 cup + 2 Tbsp.)	480 ml (2 cups)
2.4 litres (10 cups)	284 gm (1 1/4 cups)	900 ml (3 3/4 cups)

The following proportions should be remembered when adding or changing the ingredients:

fine vegetable oils: 20% of total fats; filler: 10-20% of total volume

If the soap is poured into the moulds too soon, the soap may separate into a hard bottom and a greasy upper layer. Pour too late, and there are likely to be air pockets in the mould. When pouring, do so slowly and evenly.

Rinse all pieces of equipment as soon as you have finished with them. Wash well in warm soapy water.

It may take an hour or so for the soap to be cut into bars. Use a sharp knife or a thin piece of wire held stretched in the hands. The process of saponification is not complete until the soap is fully set. Weather and the location of the moulds may affect the time it takes to harden. Also soaps containing vegetable oils are likely to take longer to set. Peel off cardboard moulds. Curing should take at least three weeks.

Use the chart *Soap Defects: Causes and Remedies* to determine the cause of defects to soaps, and then try to correct mistakes in the preparation of a second batch of soap.

To reclaim a soap, pour the soap with its liquid into a pot along with half of its volume of water. Melt and bring to the boil, simmering until it forms stringy ropes from the spoon. If it does not, add more water, as it can easily be boiled away. Pour into moulds to set.

Leaflet no. 87 Activity 2: Extension Activities

Divide older students into groups and have

each group make batches of soap with different ingredients (that is, one group uses different lyes; another group uses different types of water; another group experiments with different types of fats and oils; a fourth group mixes different fillers with the liquid soap mixture; and the final group makes a batch of soap with emollients). Make sure each group records how it produces the soap, their observations and their product. The soaps should be marked, and then available for testing in the activities outlined in Leaflet no. 88.

You can buy household lye (caustic soda) from a hardware or grocery store as sodium hydroxide pellets or flakes. Have students collect water samples from springs, wells and streams if possible.

You could have students think of other ingredients to add to the soap. Limit additions to the following substances: aloe vera, baking soda, lemon juice, buttermilk (in liquid or powder form), coconut oil (makes lots of suds) or cornstarch (can leave a thin film on skin that might attract bacteria). Make sure no poisonous ingredients are added to the soap. Poisons can be absorbed through the skin.

These ingredients should be added after the soap has saponified, while it is still cooling. Fragrances could also be added: these should be the last ingredients, and added just before the liquid soap is poured into moulds.

Soap Defects: Causes and Remedies		
Symptom	Cause(s)	Prevention/Remedies
Greasy layer on top of hard soap	Liquid soap poured too soon; lye poorly distributed; incomplete saponification.	Stir more thoroughly; do not pour until thick and creamy; measure accurately.
Greasy layer on top of liquid soap	Inaccurate measurements; inaccurate temperatures; rancid, salty fat.	Clean fat properly; follow directions carefully.
Soft, greasy soap	Incomplete saponification; too little lye; hard water used, taking up some lye.	Soften water before use; measure accurately.
Streaky soap	Too little stirring; uneven emulsion.	Pour lye slowly into the fat; stir well; measure temperatures more accurately.
Very hard, brittle soap	Too much lye; fat too hard (mutton).	Measure lye accurately; add vegetable oil.
Cracks in soap	Too much lye; too much stirring; too thick when poured; too fast in setting.	Reduce lye; pour when creamy thick; set at room temperature away from strong heat.
White residue on hard soap	Too much lye; hard water.	Use rain water; measure accurately.
"Fatty-smelling" soap	Free fat which turns rancid; odorous fats.	Stir well; accurate proportions; render fat at low heat; use fresh fat; wash fats before making soap.

(From: *The Art of Soap Making: A Complete Introduction to the history and craft of fine soapmaking* by Marilyn Mohr published by Camden House Publishing, 1979)

**Leaflet no. 87 Activity 3:
Making soft soap by the hot method**

This recipe is provided so that students have an opportunity to produce soap on a large scale for use by their community. The recipe describes how soap was made before commercial dry flaked lye became available.

A large batch of soft soap can be made outside in a ten-gallon cast iron pot. Melt down 12 pounds of clean rendered beef tallow over a fire, and gradually add four five-gallons of lye-water.

Use the chart *Soap Defects: Causes and Remedies* on the previous page to identify defects in the soap and ways to remedy the situation.

**Leaflet no. 87 Activity 3: Extension
Activity**

Common salt (sodium chloride) is used for 'graining' the soap out from a mixture of glycerine, water and impurities. Several handfuls of sodium chloride should be added to boiling soap.

Comparing soaps

Have students use their senses to compare the soaps the class has made. What do each of the soaps look like? Feel like? Smell like? Can the students explain some of these differences?

Leaflet no. 88 explores other ways to compare home-made soaps and commercial soaps. Gather together all the home-made soaps produced in activities in Leaflet no. 87. These are to be tested by the students in activities in leaflet no. 88. While younger students should not carry out the soap-making activities, they are quite capable of testing the soaps.

**Leaflet no. 88 Activity 2:
Which soap mixes oil and water best?**

This activity is about emulsification, a process by which liquids, which do not usually mix, become mixed. This occurs when an emulsification agent is added. In this case, soap and water is acting as the emulsifying agent. Have the students find out if the amount of soap solution added changes the effect. Ask them: "Do the mixtures look the same after they have been shaken as they did before they were shaken? An hour later?"

**Leaflet no. 88 Activity 3: Which soap
is the best at attacking grime?**

Point out to the students that every attempt has been made in this experiment to control variables so that all soaps undergo the same tests. Have the students identify the variables being controlled, (e.g. the amount of soap and water being used, the smoothing of the banana/dirt so that there is the same amount of grime that needs to be removed).

**Leaflet no. 88 Activity 4:
Measuring suds**

In this activity students have fun testing soap for suds-making ability while developing mathematical skills of measurement, calculating volume and data recording.

Your students can also compare suds by putting the same amount of each soap sample in separate jars with equal amounts of water. have them secure lids on the jars and then shake each jar vigorously. The students should observe and describe what happens. Does it make a difference how much soap is used in each case? What happens to the suds when the sudsing mixture is allowed to stand for 10 minutes? An hour?

EXPERIMENTAL RESULTS

**Leaflet no. 87 Activity 2:
Making hard soap by the cold process**

As the lye is stirred into the fat, the mixture will become cloudy, then somewhat grainy. As it becomes ready for pouring, the mixture will thicken like a creamy honey. It is difficult to achieve complete saponification using this method. There is often a small amount of free fat which may become rancid, producing foul-smelling brown spots on the soap. If, on the other hand, there is free lye, then the soap produced is a harsh soap.

The soap should appear smooth and white with an even texture. But sometimes things go wrong. The lye becomes separated from the mixture. Perhaps, the ingredients have not been measured carefully or the lye and water solution is too hot or too cold. Or maybe the fat/lye mixture has been stirred too vigorously, or not thoroughly enough. Any defects in the soap will be evident from its appearance. Make copies of the chart *Soap Defects: Causes and Remedies* for students to identify defects and discover what remedies should be taken to

put matters right.

Leaflet no. 87 Activity 3: Extension Activity

The salt has a stronger affinity for water than has soap. Therefore, the salt takes the water from the mixture, and causes the soap to separate and rise on the surface of the liquid in a curdy, granulated state. Students will see a red-brown liquid sink to the bottom of the pot. The liquid contains glycerine, salt and other impurities. Skim off the soap. As it cools the soap should form a cake.

Home-made soap versus commercial soap

Home-made soap is likely to last longer than a commercial one because of the glycerine that it contains. When an oil is saponified, glycerine is a by-product of the reaction. Glycerine is often removed from commercial soaps. Except when home-made soap is "salted out", home-made soap retains glycerine. A clear, syrupy, very viscous liquid, glycerine has a strong affinity for water. As a result, home-made soap generally contains a much higher percentage of water and is considerably less dense than commercial soap.

The high proportion of water in home-made soap may lead to shrinking and sweating as it sets. This does not happen with commercial soaps. Because commercial soaps contain little moisture, when they are put in water, they absorb it rapidly. This produces a film around the bar and a quick and copious lather. A large amount of soap is washed away.

Home-made soap does not lather as easily because it already contains a great deal of water. It does not soften as quickly on contact with water. The dense commercial bars tend to crack and break when well-used, whereas the home-made bars maintain their shape down to a fine sliver. Thus, less home-made soap is wasted.

Leaflet no. 88 Activity 2: Which soap mixes oil and water best?

This experiment follows up on Activity 1 by actually showing the ability of soap to make oil and water mix. Results will vary depending upon the soaps being tested. As a general rule, the oil and water separate again after two or

three minutes but they do mix much better with the soap than without it.

Leaflet no. 88 Activity 3: Which soap is the best at attacking grime?

Results will vary depending upon the soaps your students are testing.

Leaflet no. 88 Activity 5: Market research

The benefits of making soap will vary depending upon local conditions. For example, in remote places where commercial soap is not readily available and where there is a plentiful supply of animal fat, wood ash and soft water, then it might be advantageous to make soap, especially as a communal activity. However, in towns where soap is inexpensive or in places where fuelwood is scarce, then home-made soap production would not be recommended.

GOING FURTHER

Experimenting with soap

There are many more experiments that can be tried with soap. Have students think of questions about soap, and then try experiments to see if their questions can be answered. Some questions are listed below. Encourage students to try to investigate the answers. Also encourage them to ask their own questions and to experiment in their own way. Make sure they are not discouraged if their questions are not answered or if their experiments fail. Be sure that they try again, perhaps asking new questions or trying different experiments to answer the same questions. Whatever they do, have the students observe all their experiments carefully, and keep notes on what they do and what happens.

- * *On solubility:* Does the temperature of the water in which soap is placed affect the rate at which soap dissolves? Does stirring have the same effect? What effect does adding vinegar have upon the rate at which soap dissolves? What other factors influence the rate at which soap dissolves?
- * *On lubrication:* Do hands rubbed together pass over each other easier when they are dry or when they have soap and water on them? Is a dry bar of soap a better lubricant than a wet bar of soap? Can a soap solution be used to lubricate a bicycle?

- * *On density:* What happens to a bar of soap that has been melted and beaten with a fork as it cools? Is there any difference between melted-beaten soap and a bar of the same kind of soap when they are placed in water? Does the weight of a bar of soap change after it has been melted, beaten and cooled?
- * *On bases:* When leaves of red cabbage are soaked in alcohol, the colour of the cabbage can be seen in the alcohol. What happens when chips of soap are dropped into the cabbage-coloured alcohol? What happens when vinegar is added to the red-cabbage water?
- * *On viscosity:* Is there any difference between the motion of a small rock that is falling through a bottle full of liquid soap and the same rock falling through a bottle of equal size but full of water?

RESOURCES

Publications used as references for these notes on soap-making include the following: Third World Science unit, *Soap*, produced by Third World Science Project, School of Education, College of North Wales, 1982; Phyllis Hobson *Making home-made soaps and candles* (Garden Way Publishing, Vermont 1974); Marilyn Mohr, *The contemporary art of soap making* (Camden House Publishing, 1979); Mary Lynne Bowman and Herbert L. Coon *Recycling: Activities for the classroom* (ERIC Clearinghouse for Science, Mathematics, and Environmental Education, 1978); A. Harris Stone and Bertram M. Seigel *The Chemistry of Soap* (Prentice-Hall Inc, 1968)

LEAFLET NO. 89: MAKING NEW THINGS FROM OLD (5) MAKING A LIVING FROM PAPER BAGS

TEACHER'S TIPS

In this leaflet, students will

- * look for ways to conserve natural resources and make a living by recycling materials;
- * understand some of the pressures of trying to survive in an economy where there is massive unemployment and no social security;
- * develop some business skills;
- * develop mathematical skills.

You can introduce the project by asking the following questions:

- a) How can you make money?
- b) How many of you actually do so?
- c) If you were allowed to work full time, what sort of work would you be able to do? What sort of work would you not be able to do? Why?
- d) How many hours a day/days a week would you think it reasonable to work?
- e) How much of your earned income do/would you keep for yourself and how much do/would you give to your family?

Then ask students to think of ways of making a living by recycling materials. They may suggest making and selling products that they have designed in Learning-By-Doing

leaflet nos. 85/86 and 87/88. Or they may talk about recycling businesses that are already operating in their community.

Explain to the students that they are going to see if they can make a living from a recycling business. They may be interested in a recycling business that has not been tried in the community before. Alternatively, they may opt to investigate an existing business, and assess its profitability. This last alternative offers opportunities for students to develop survey techniques by interviewing local entrepreneurs to find out about the pitfalls and rewards of setting up a business.

The example of a recycling business cited in the leaflet is paper bag manufacturing in Calcutta, India. This example is drawn from information in *The Paper Bag Game* a simulation game about poverty issues in Calcutta, published by Christian Aid. For further information, write to: Christian Aid, P.O. Box 100, London SE1 7RT, United Kingdom.

Have the students try the exercises in the leaflet that are related to paper bag manufacturing, and then use what they learn to explore a recycling business that they are interested in. The processes outlined in this leaflet for paper bag manufacturing can be

applied to other businesses that the students decide to explore. In the exercise, the students will find out about the availability of scrap and other raw materials; assess demand for their product(s); and work out if the business offers a potential livelihood.

Activity 1: How to make a paper bag

Have the students work in groups. You could prepare sample bags beforehand so that each group has one to copy. You may also find it helpful to prepare a demonstration set showing each step in the process. For sources of used paper for recycling, see page 31.

Once the class has tried the paper bag activities in the leaflet, have the students explore other recycling business(es). Whatever business(es) the students decide to explore, it is important to give them time to experiment with the making of the product. If they work in groups, the groups can look into ways of making different products, or each group can try different ways of making the same product. In the case of the former, the students should remain in the same groups throughout the project; in the case of the latter, groups can pool their results from this activity.

Activity 2: Market research

Different products demand different markets. If groups are making different goods, it might be a good idea to have the class brainstorm together to identify local markets for each product.

Activity 3: Which bag is the one to make?

Students should design their own strength tests, so try to have a range of equipment available for students to use for testing. The

testing required for other products depends upon what the products are to be used for.

Activity 4: Meeting demand

Make sure there is an ample supply of scrap paper available for this exercise. A member from each group can serve on a quality control panel of 'experts' to check for substandard bags (or other products).

Observe how each of the groups organises itself when the students make bags (or other products). Some groups will operate a production line with each member specialising in one task; in other groups, individuals will make their own bags from start to finish. At the end of this activity, have a class discussion on the merits of each approach.

The leaflet stipulates 40 hours of work a week, but students might discuss the merits of this work week, and then set their own hours per week.

Activity 5: Material source

It would be a good idea for you to check out local supplies of recyclable materials before students finalise their plans for going into production (as in Activity 1).

Activity 6: Can you make enough for you and your family to live on?

Have the class as a whole draw up a list of items that might need to be purchased in order to survive in your community. The list might include rent, food, clothes, cooking fuel, transport and so on. The cost of the items can be researched by individual students. Write up the price list on the board or on a large sheet of paper. Put it where all can see. It may look something like the price list below. This shows costs in Calcutta (1989).

Price List in Calcutta		
<i>Food:</i>		
1 kilo of vegetables	R6.00	
1 kilo of rice:	R2.00	
6 oranges:	R5.00	
6 bananas:	R3.00	
1 litre of milk:	R7.00	
1 dozen eggs	R6.00	
1 kilo of ghee (butter)		
for cooking)	R60.00	
cup of tea	R0.50	
<i>Medicines:</i>		
doctor's fee	R20.00	
50 antibiotic tablets	R60.00	
bottle cough mixture	R10.00	
<i>Other goods:</i>		
rent for a bustee		
home (a month):	R150.00	
1 litre of paraffin:	R4.00	
blanket	R40.00	
primus stove	R75.00	
saucepan	R30.00	
1 kilo soap	R10.00	
<i>Sundries:</i>		
daily newspaper		R1.50
return rail ticket		
(Delhi- Calcutta)		R250.00
bus ticket in Calcutta		R1.00
<i>Clothes:</i>		
trousers		R100.00
shirt		R60.00
cheap sari		R50.00
cheap sandals		R20.00

Have students discuss in class what might be the daily/weekly expenditures for (a) an individual and (b) a family of five living in their community. Then, have each student use the class price list to draw up his/her own expenditure list for his/her family, taking into account different lifestyles and household sizes.

Each student can use the data collected in Activity 4 to work out the hours he/she would have to work in order to earn enough money to meet the family's living requirements. Ask the students if they think they could have produced

more bags if they had worked in a different way?

Students may consider other sources of household revenue when they work out the contribution that the paper bag business (or other recycling business) must make towards covering household expenditures.

When estimating the income derived from a recycling business, all business related expenditures, such as workers' pay, the cost of materials, equipment and so on, should be deducted first to reveal the net profit.

GENERAL RESOURCES

WonderScience magazine was used as a source of reference for leaflet nos. 84 and 88. The magazine is published monthly from October to May, and is a joint effort of the American Chemical Society, 1155 Sixteenth Street, N.W., Washington, D.C. 20036 USA and the American Institute of Physics, 1 Physics Ellipse, College Park, MD 20740, USA. Each issue includes fun physical science activities for children and adults to do together, and has an accompanying letter to the teacher explaining science activities. Back issues include such topics as plant science, insulation, earthquakes, playground physics and water. For subscription information, write to *WonderScience* at the ACS address.

SuperScience Blue was used as a source of reference for leaflet nos. 83 and 84. The magazine is published eight times a year (monthly in September and October, bimonthly in November/December and monthly from January to May) by Scholastic Inc., P.O. Box 3710, 2931 East McCarty Street, Jefferson City, MO 65102-3710, USA. *SuperScience Blue* is for students in Grades 4 to 6 (ages 9 to 12 years). Each issue explores a science theme such as Wetlands in Danger, Preservation, Vision, Growth, Volcanoes and Climate. While the magazine is aimed at an American readership, many of the activities have universal application. A Teacher's Edition is also available. For subscription information, write to *SuperScience Blue* at the above address. Also available is *SuperScience Red* magazine for children in Grades 1-3 (ages 6 - 9 years).